

REVISIONS				
P.	LTN	DESCRIPTION	DATE	APVD
A		RELEASED	11MAY2006	LAM JW
B		ECO-15-006810	22JAN2016	LL SH
C		REVISED PER ECO-21-000623	28JAN2021	AK SZ

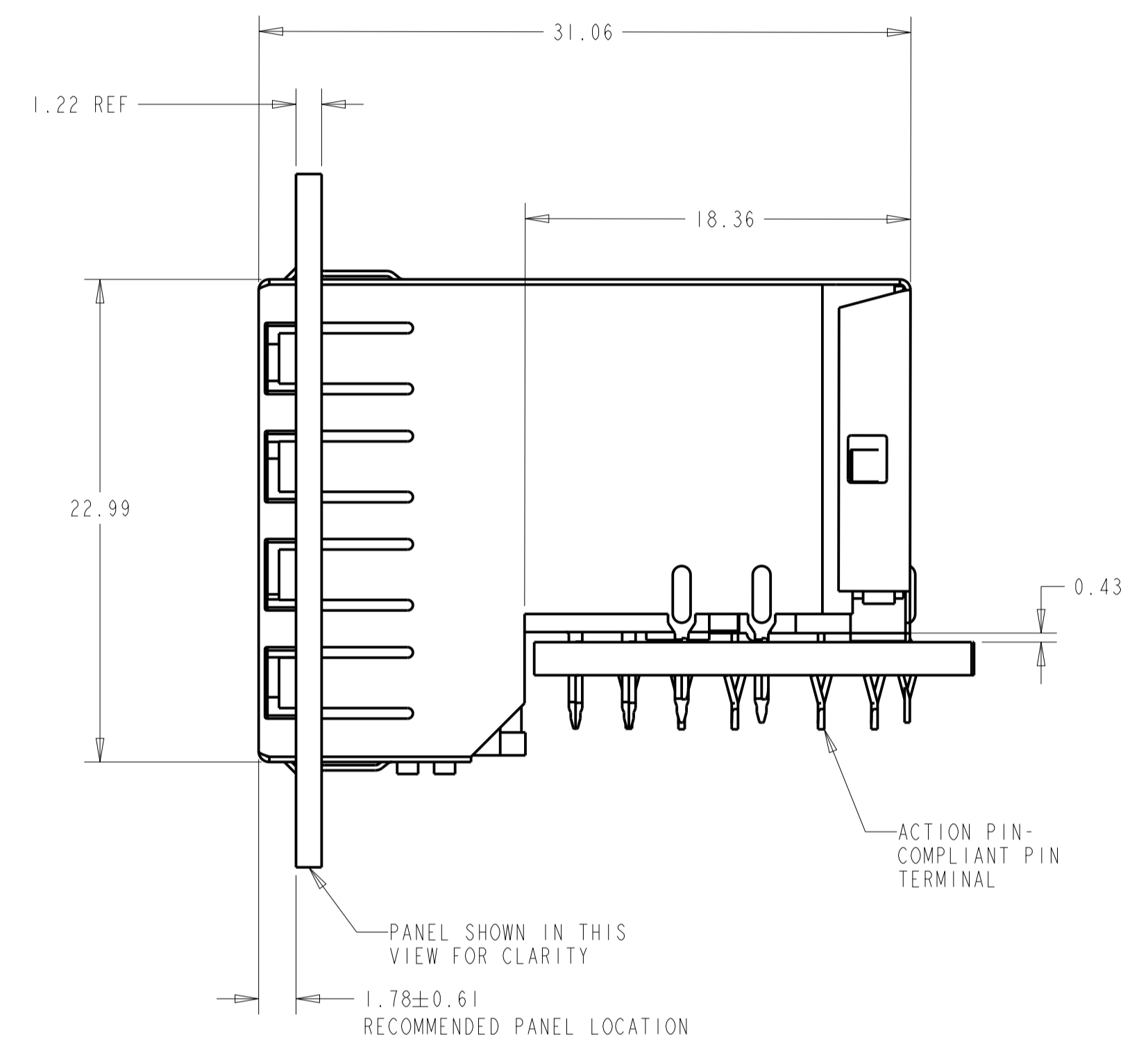

- MATERIAL:  
HOUSING: PBT POLYESTER, BLACK, UL 94V-0.  
TERMINALS: 0.33 THICK PHOSPHOR BRONZE PLATED WITH 1.27µm MINIMUM THICK HARD GOLD IN LOCALIZED AREA AND 3.81µm MINIMUM THICK MATTE TIN IN ACTION PIN COMPLIANT PIN TERMINAL AREA OVER 1.27µm MINIMUM THICK NICKEL UNDERPLATE.  
SHIELD: 0.25 THICK COPPER ALLOY PLATED WITH 1.27 µm MINIMUM NICKEL.  
LIGHT EMITTING DIODE (LED): DIFFUSED EPOXY LENS, 12.95 CARBON STEEL WIREFRAME LEADS PREPLATED WITH 8.89 µm THICK Sn/Cu OVER 2.03 µm THICK Ag OVER 1.02 µm THICK Cu OVER 3.56 µm THICK Ni OVER 1.02 µm THICK Cu UNDERPLATE.  
LED ACTION PIN - COMPLIANT PIN CONTACTS: 0.3 THICK BRASS PLATED WITH 2µm MINIMUM MATTE TIN OVER 1.27µm MINIMUM NICKEL UNDERPLATE.
  - JACK CAVITY CONFORMS TO FCC RULES AND REGULATIONS, PART 68 SUBPART F.
  - ALL DIMENSIONS ARE NOMINAL UNLESS OTHERWISE SPECIFIED.
- 4 DATUMS AND BASIC DIMENSIONS ESTABLISHED BY CUSTOMER.  
 5 DATE CODE LOCATED ON REAR OF PART APPROXIMATELY AS SHOWN.  
 6 CONTACTS ARE NOT INTENDED TO BE ALIGNED WITH EACH OTHER.  
 7 SUGGESTED OPERATING CURRENT FOR LEDS IS 20 mA.  
 8. TWO LEDS PER PORT, SIZE .079 X .118, SEE TABLE FOR COLOR

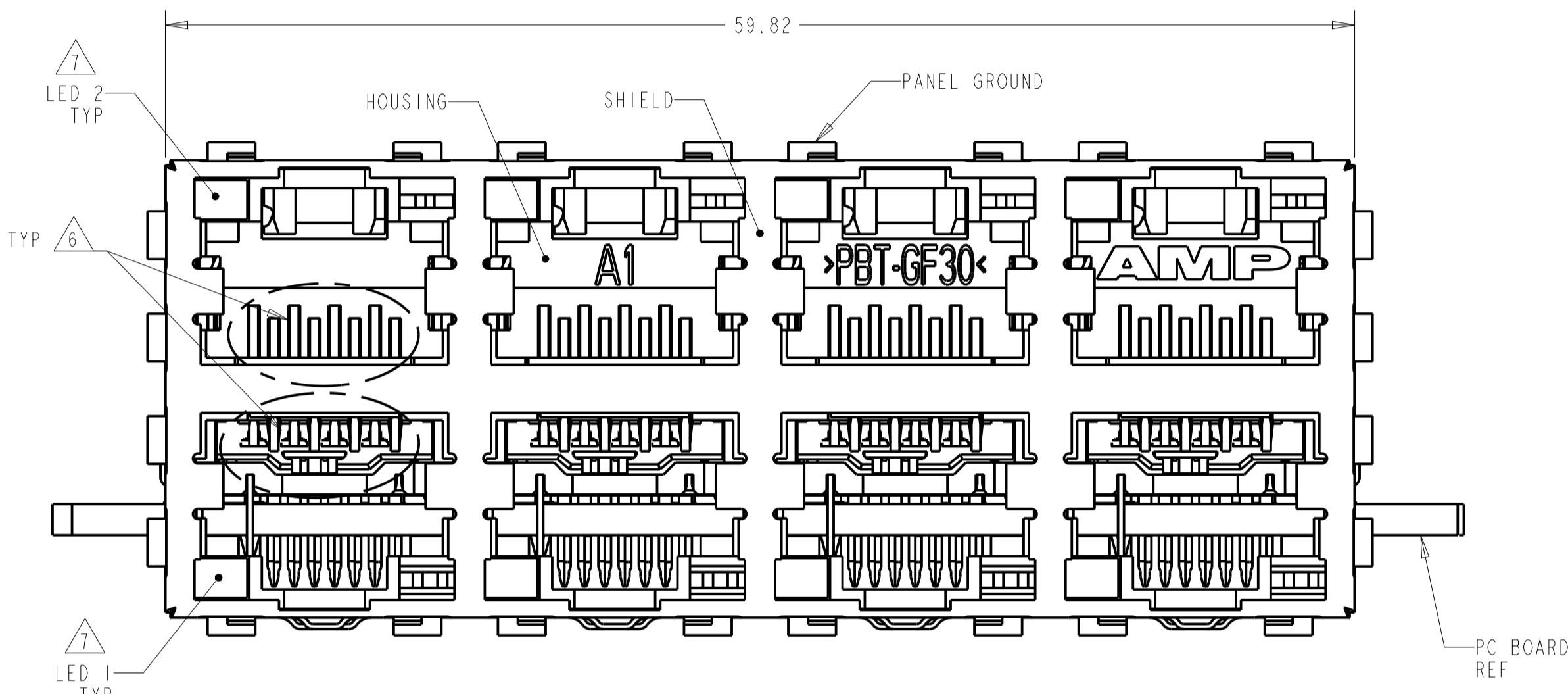
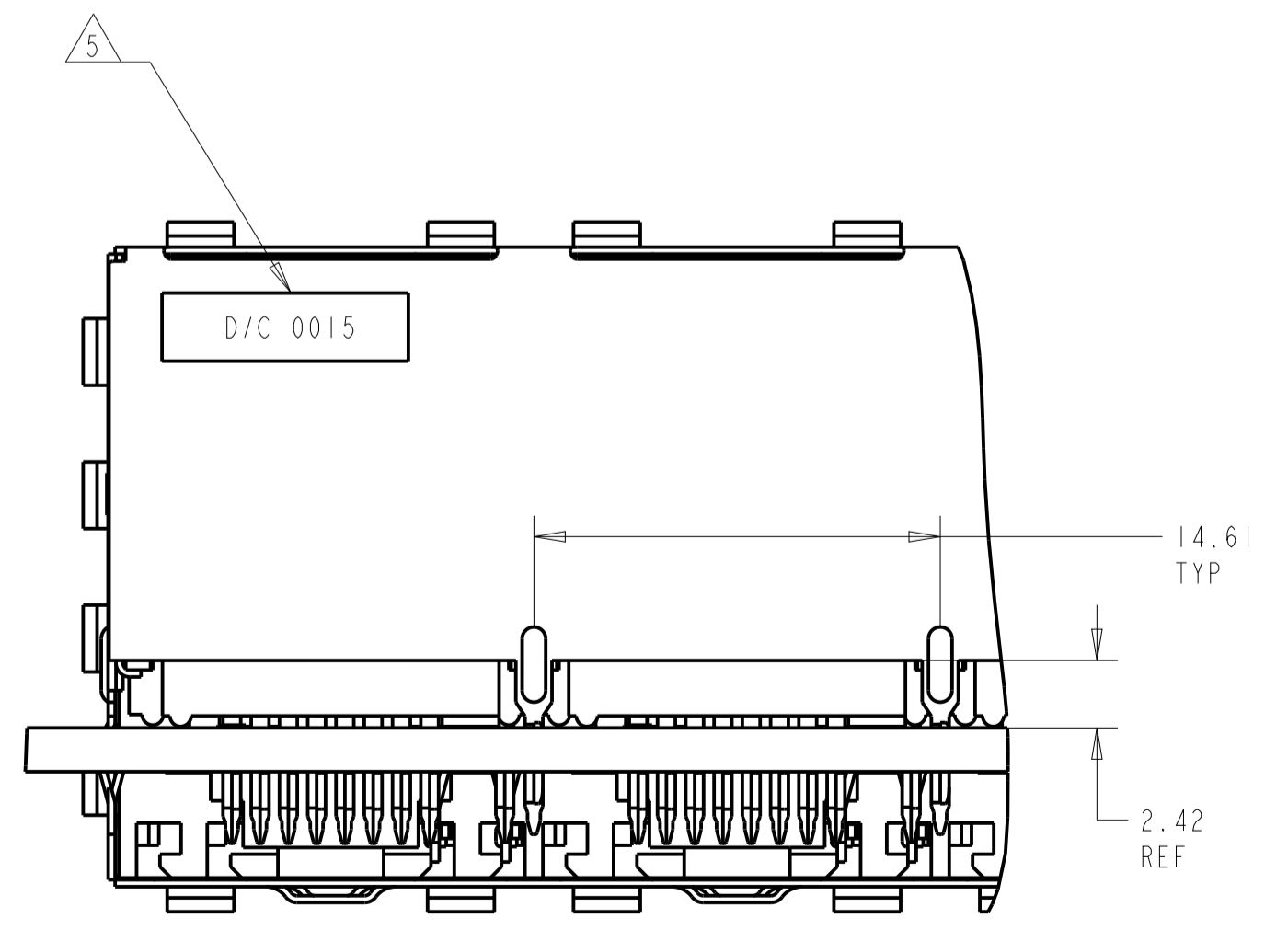

PARTIAL BACK VIEW

-		GREEN/YELLOW	GREEN/YELLOW	1888315-1
LED #4 (LOWER-RIGHT)	LED #3 (UPPER-RIGHT)	LED #2 (UPPER-LEFT)	LED #1 (LOWER-LEFT)	PART NUMBER
THIS DRAWING IS A CONTROLLED DOCUMENT.				
DIMENSIONS: mm 		TOLERANCES UNLESS OTHERWISE SPECIFIED: 0 PLC ± 1 PLC ±0.1 2 PLC ±0.13 3 PLC ± 4 PLC ± ANGLES ±1 FINISH SEE NOTE 1		
MATERIAL SEE NOTE 1		DWN: R. GRZYBOWSKI / J.LAM CHK: J. WESTMAN APVD: S. ELICKINGER PRODUCT SPEC: 108-1854 APPLICATION SPEC: 114-2160 WEIGHT: - CUSTOMER DRAWING		
A1		NAME: STACKED MODULAR JACK ASSEMBLY, 2x4 OFFSET, WITH LEDS, 8 POSN, RJ45 SHIELDED, PANEL GROUNDS, CAT 5 SIZE: 00779 CAGE CODE: 1888315 SCALE: 4:1 SHEET 1 OF 2 REV C		

REVISIONS				
P.	LTN.	DESCRIPTION	DATE	APVD.
-	-	SEE SHEET 1	-	-

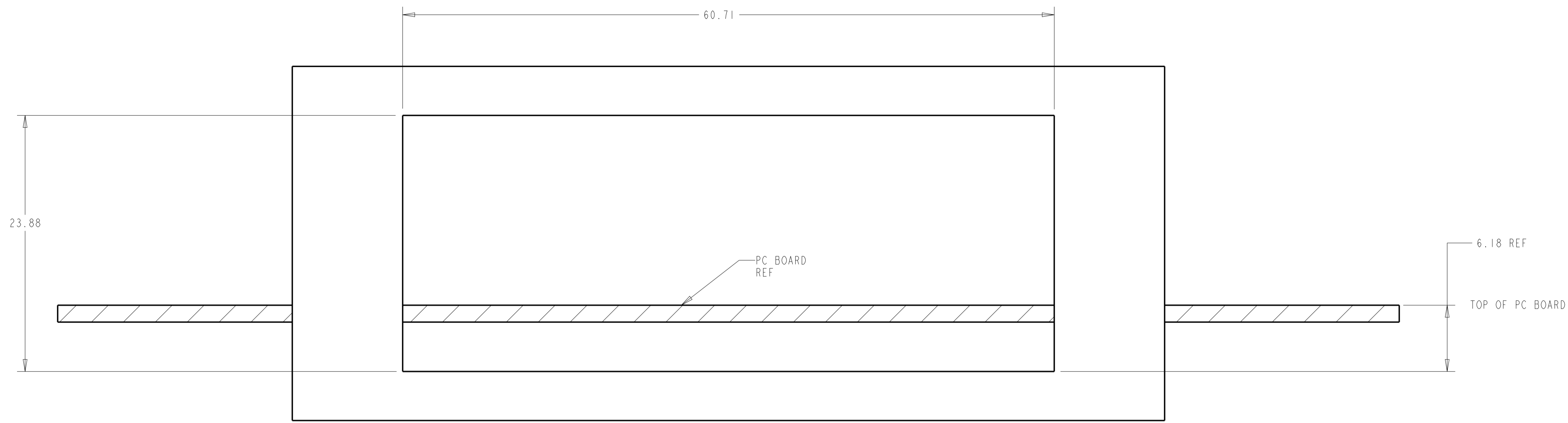

RECOMMENDED PANEL CUT-OUT

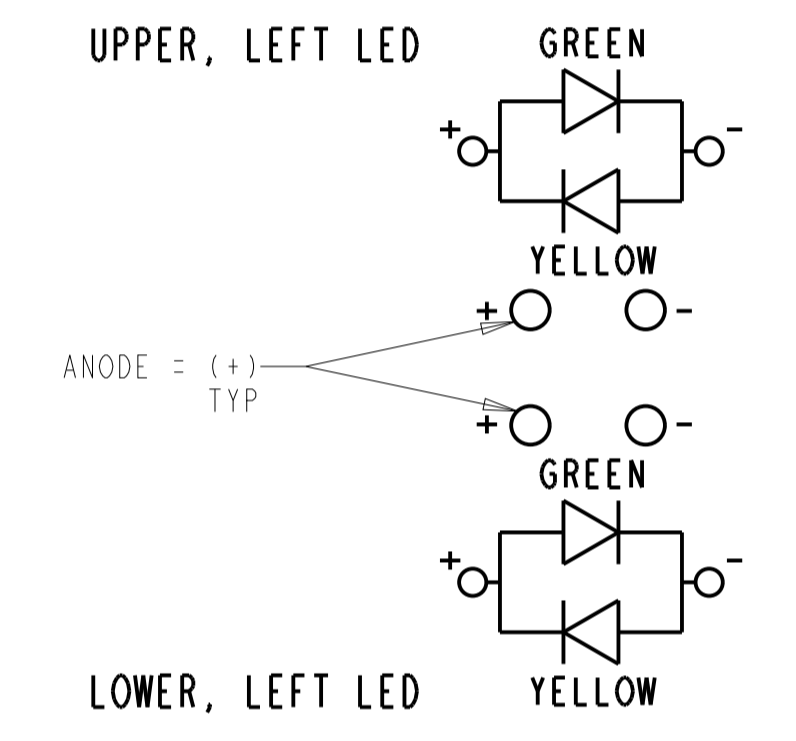

LED SCHEMATIC

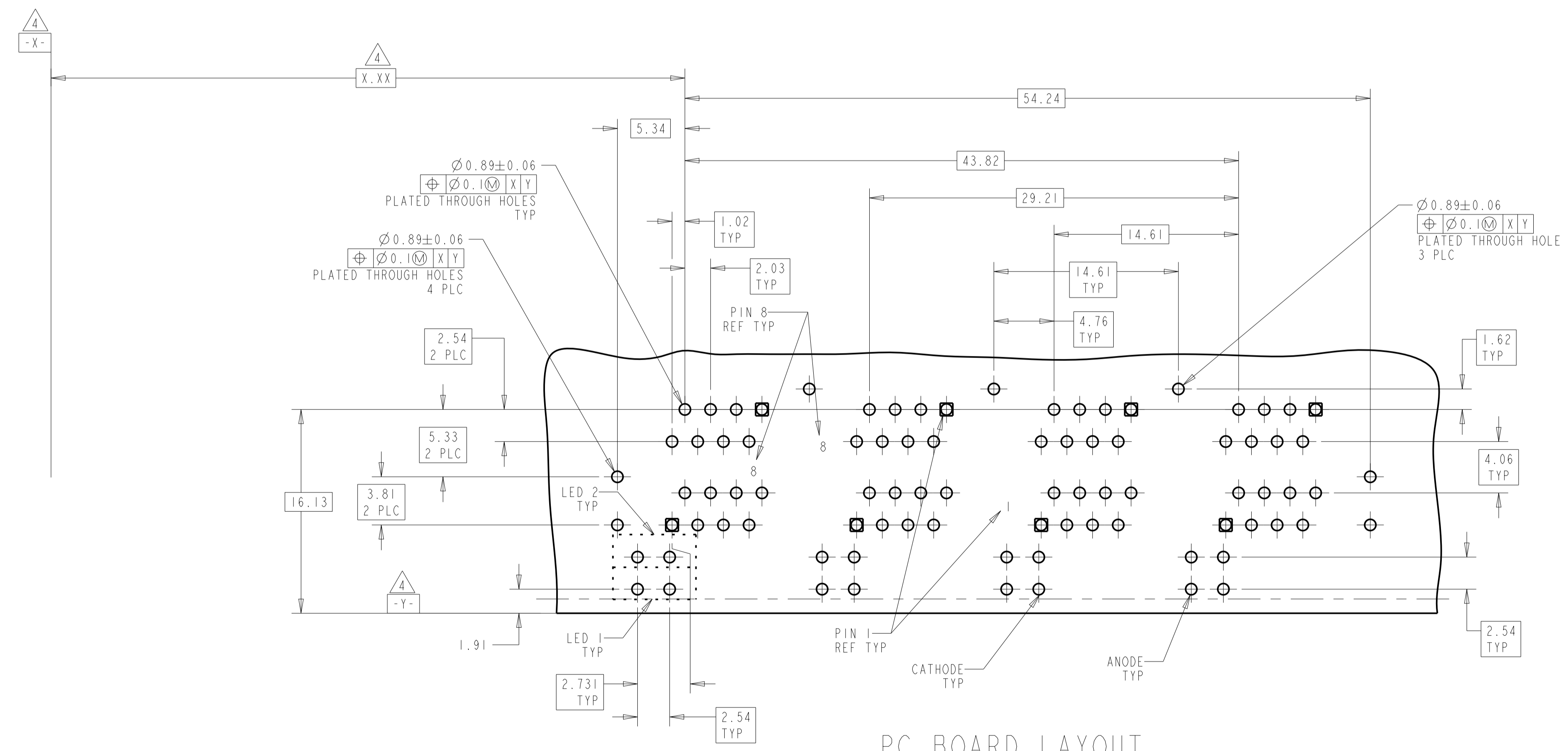

PC BOARD LAYOUT (COMPONENT SIDE)

THIS DRAWING IS A CONTROLLED DOCUMENT.		OWN: R. GRZYBOWSKI / 1MAY2006	<b>STE</b> TE Connectivity
DIMENSIONS: mm		CHK: J. WESTMAN / 1MAY2006	
TOLERANCES UNLESS OTHERWISE SPECIFIED:		APVD: S. FLICKINGER / 1MAY2006	NAME: STACKED MODULAR JACK ASSEMBLY, 2x4 OFFSET, WITH LEDs, 8 POSN, RJ45 SHIELDED, PANEL GROUNDS, CAT 5
0 PLC ±	1 PLC ±0.1	PRODUCT SPEC: 108-1854	
2 PLC ±0.13	3 PLC ±	APPLICATION SPEC: 114-2160	
4 PLC ±	ANGLES ±1	WEIGHT: -	
MATERIAL: SEE NOTE 1	FINISH: SEE NOTE 1	CUSTOMER DRAWING	SIZE: A1
CAGE CODE: 00779		DRAWING NO: 1888315	RESTRICTED TO: 2 OF 2
SCALE: 4:1		SHEET: 2	REV: C

单击下面可查看定价，库存，交付和生命周期等信息

[>>TE Connectivity\(泰科\)](#)