

REVISIONS					
P	LTR	DESCRIPTION	DATE	DWN	APVD
A		EGA0-0352-036	14OCT2003	JJ	HW
A1		EGA0-0621-03	22OCT2003	JJ	HW
A2		ECR-05-007181	18JUL2005	JJ	WSI
A3		DRAWING UPDATED. NEW TE LOGO. ECR-15-002468	12MAY2015	Abr	Brun

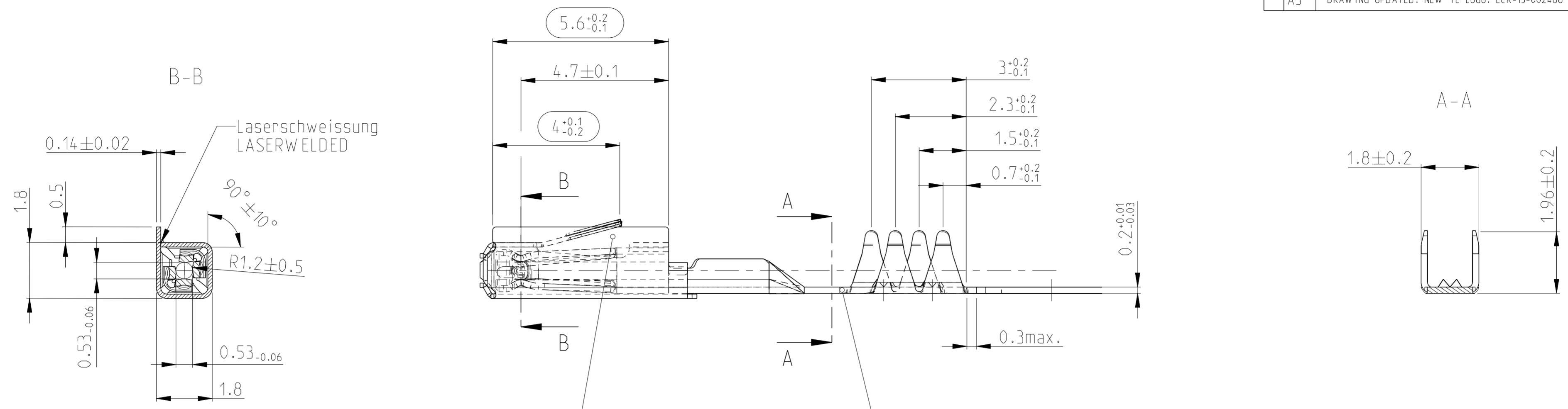

Ueberfeder / SPRING
 Material: X10CrNi 18 8
 DIN 17224
 Oberflaeche / SURFACE: blank

Kontaktkoerper / BODY
 Material: CuNiSi
 Oberflaeche: siehe Tabelle
 SURFACE: SEE CHART

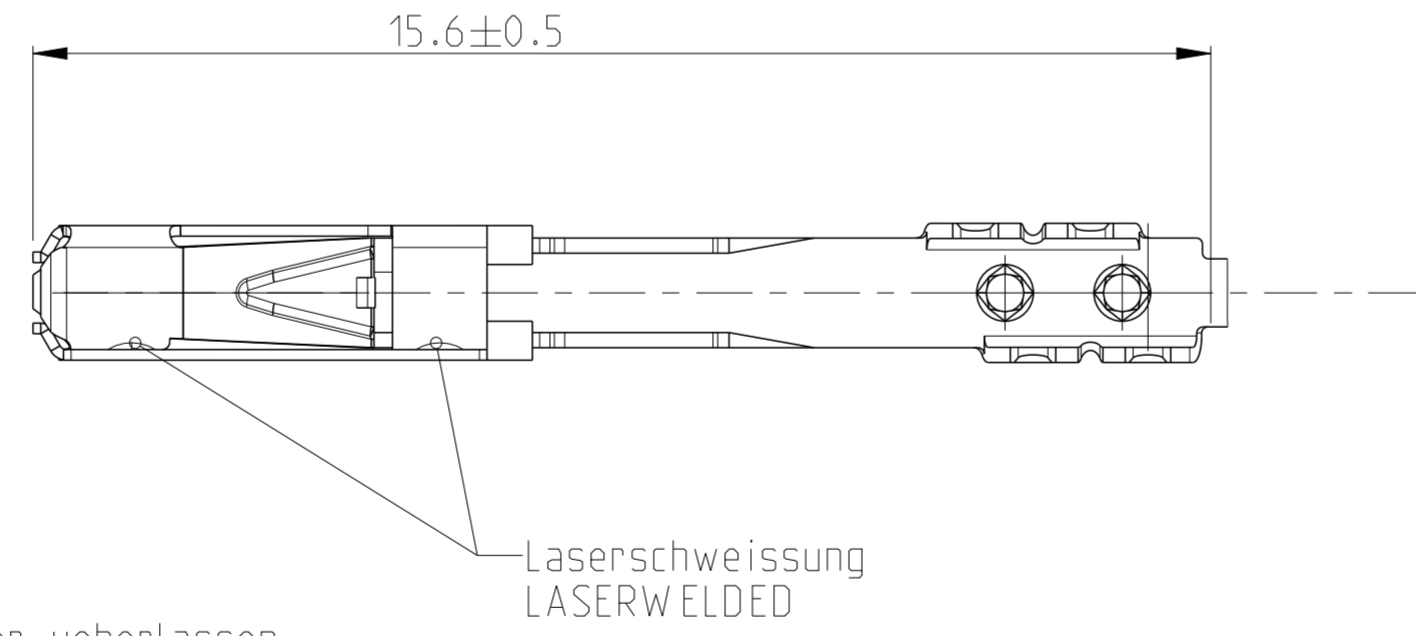

Bemerkungen
 NOTES

-
-
- 1 Einzelheiten der Ausfuehrung bleiben dem Hersteller ueberlassen
 DETAILS OF DESIGN ARE LEFT TO MANUFACTURER
- 2 Passend zu Stiftkontakt siehe Zeichnung: PN: 929453
 SUITABLE FOR PIN CONTACT SEE DRAWING:
-
-

Sn: verzinnete Ausfuehrung TINNED
 Kontaktkoerper: 0.8-2 µm Sn
 BODY: 0.8-2 µm Sn

1418887-1	A1	1418930-1	Sn	0.1
Bestell-Nr.: ORDER-NO.	Rev.	Einzelausfuehrung LOOSE PIECE ORDER NO	Oberfl äche SURFACE	Gewicht WEIGHT (g)

THIS DRAWING IS A CONTROLLED DOCUMENT.

DIMENSIONS: mm	TOLERANCES UNLESS OTHERWISE SPECIFIED: DIN 6930-m	DWN J.Jauris 14OCT2003	TE Connectivity												
MATERIAL	FINISH	CHK H.Wendling 22OCT2003													
<table border="1"> <tr> <td>0 PLC</td><td>±</td></tr> <tr> <td>1 PLC</td><td>±</td></tr> <tr> <td>2 PLC</td><td>±</td></tr> <tr> <td>3 PLC</td><td>±</td></tr> <tr> <td>4 PLC</td><td>±</td></tr> <tr> <td>ANGLES</td><td>±°</td></tr> </table>		0 PLC	±	1 PLC	±	2 PLC	±	3 PLC	±	4 PLC	±	ANGLES	±°	APVD	NAME
0 PLC	±														
1 PLC	±														
2 PLC	±														
3 PLC	±														
4 PLC	±														
ANGLES	±°														
		PRODUCT SPEC	MQS-CONTACT WITH NEW FFC-CRIMP MQS-BUKO mit neuem FFC-Crimp Extr.-Folie												
		APPLICATION SPEC	SIZE												
		WEIGHT	CAGE CODE												
		Customer Drawing	DRAWING NO												
		SCALE 10:1	RESTRICTED TO												
		SHEET 1 OF 1	REV A3												

单击下面可查看定价，库存，交付和生命周期等信息

[>>TE Connectivity\(泰科\)](#)