

THIS DRAWING IS UNPUBLISHED. RELEASED FOR PUBLICATION

© COPYRIGHT - BY TYCO ELECTRONICS CORPORATION. ALL RIGHTS RESERVED.

LOC	DIST	REVISIONS					
		P	LTR	DESCRIPTION	DATE	DWN	APVD
H	-		A	ECR-10-018708	14AUG2008	PW	DH
			A1	OBSOLETE	29AUG2018	K.G	W.H

NOTES:

- 1 DRAWING REPRESENTS PART VERSION "A4".
- 2 PLATING:
1,2µm MIN. NICKEL ALL OVER
0,8µm MIN. GOLD ON CONTACT AREA
0,1 - 0,3µm GOLD ON SOLDER AREA
- 3 COPLANARITY OF SOLDER SURFACES
0,10 MAX AFTER REFLOW.
- 4 DIMENSION DEPENDS ON DISTANCE BETWEEN
PWB AND BATTERY, SEE TABLE ON SHEET 3.
- 5 MARKING: VERSION (A4), PROCESS ID (##),
PRODUCTION DATE (YWW, YEAR AND WEEK).
- 6 MARKING: CAVITY ID.
- 7 PICK&PLACE AREA.

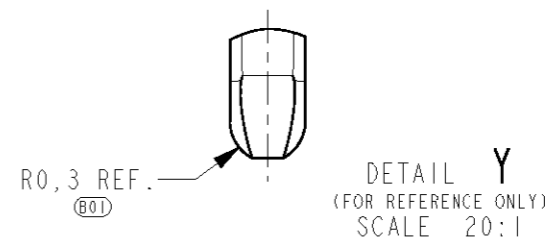
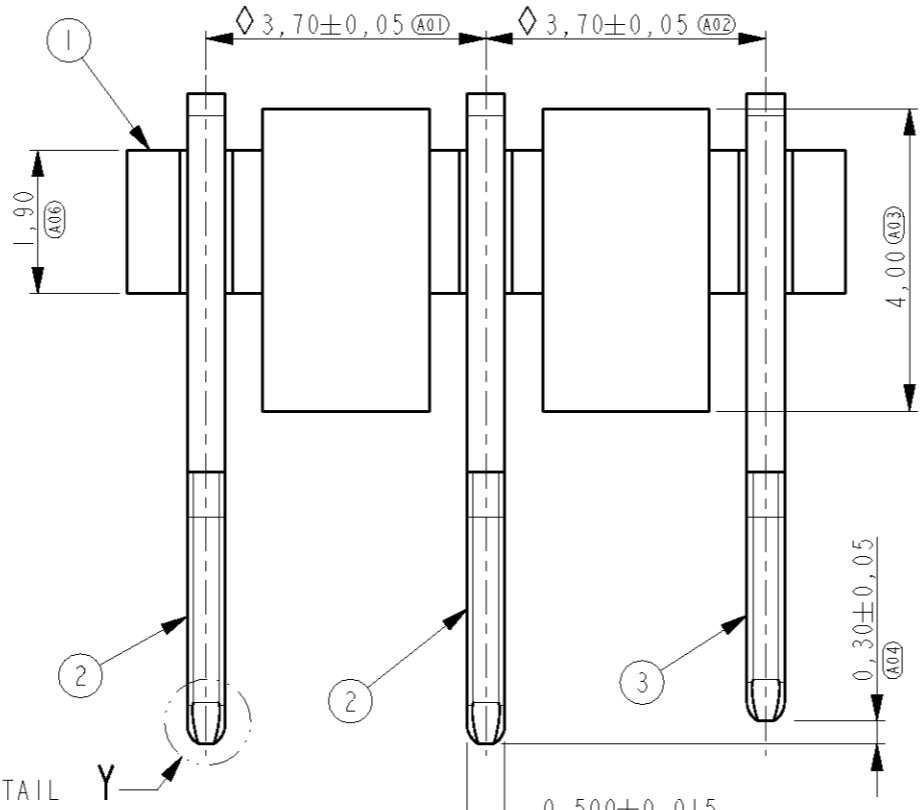

OBSOLETE

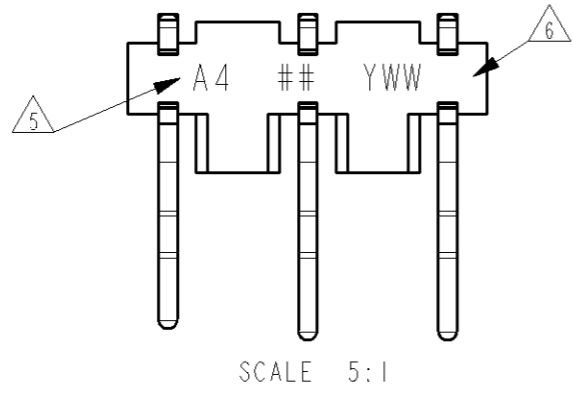
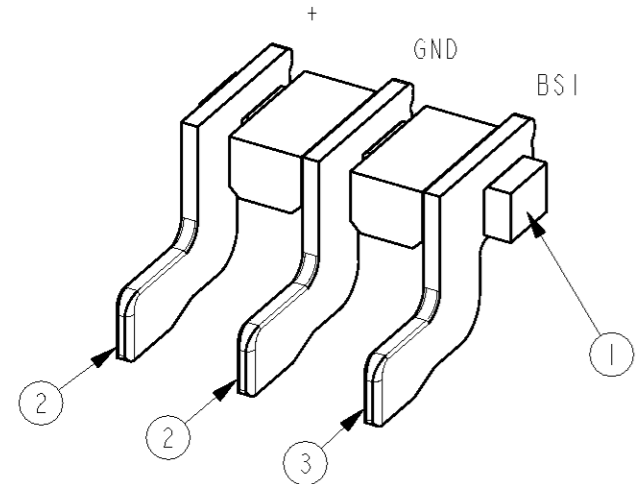
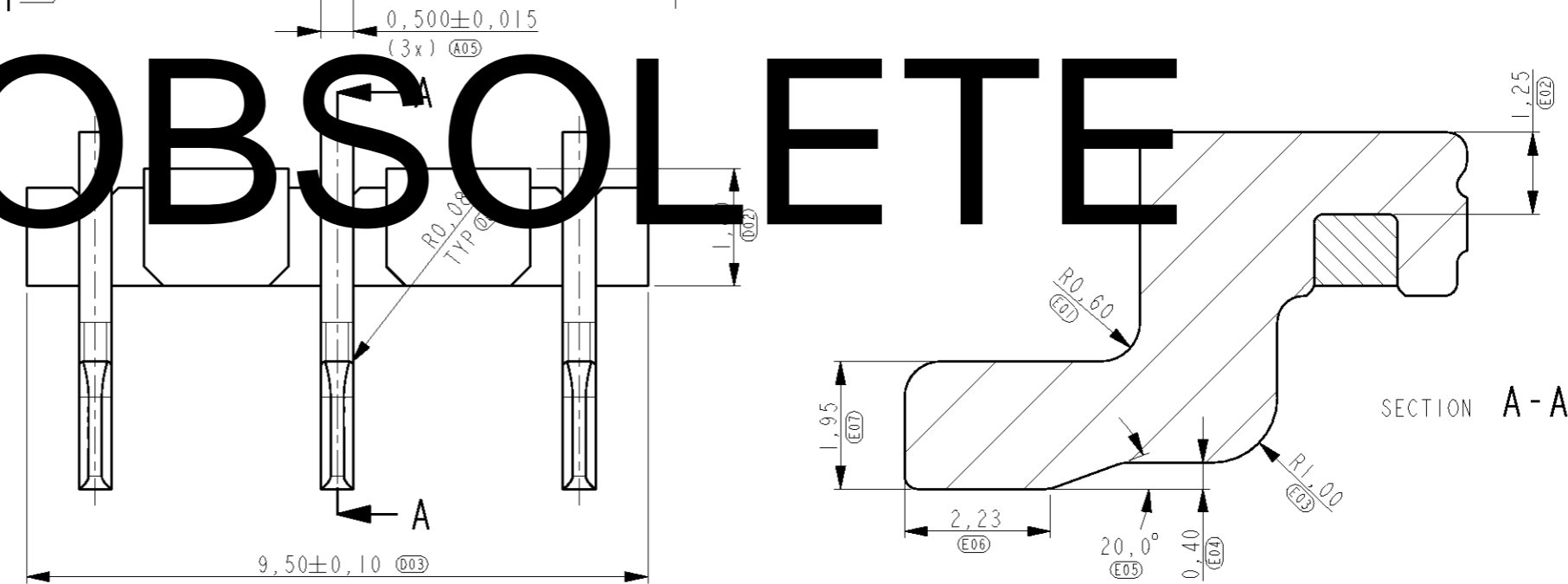
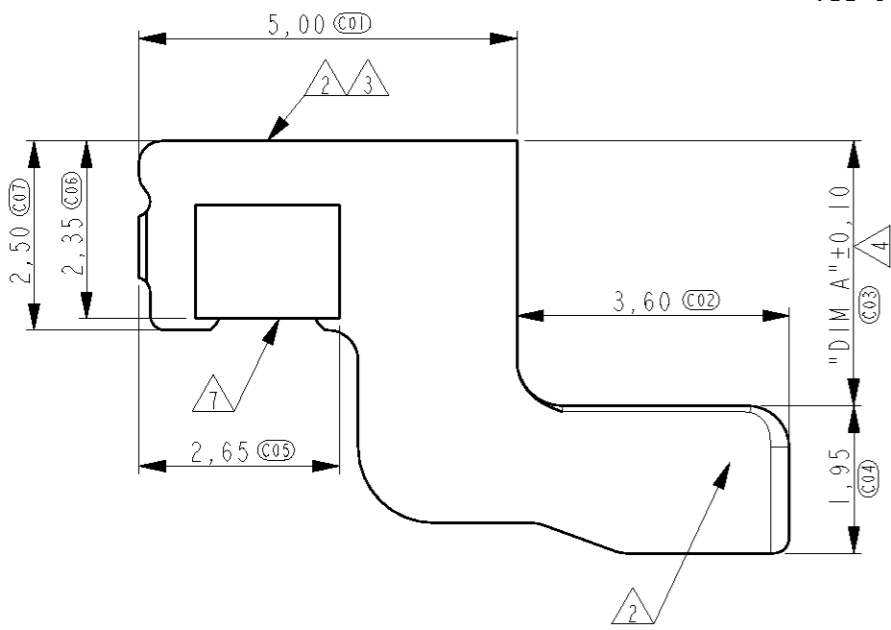

ITEM NO.	DESCRIPTION	MATERIAL	FINISH
3	CONTACT, FIRST BREAK	COPPER ALLOY	GOLD PLATED
2	CONTACT, LAST BREAK	COPPER ALLOY	GOLD PLATED
1	HOUSING	LCP, GF	-

DIMENSIONS: mm		TOLERANCES UNLESS OTHERWISE SPECIFIED:	
0 PLC	±	1 PLC	±0,2
1 PLC	±	2 PLC	±0,1
2 PLC	±	3 PLC	±
3 PLC	±	4 PLC	±
4 PLC	±	ANGLES	±
MATERIAL	-	FINISH	-

DWN P.Willems 16-MAY-07	Tyco Electronics TYCO ELECTRONICS NEDERLAND B.V. 's-HERTOGENBOSCH, THE NETHERLANDS		
CHK H.d.Otter 16-MAY-07	NAME PLUG CONNECTOR ATB-TYPE, 3 POSITION BATTERY BLOCK		
APVD D.Halberstadt 16-MAY-07	PRODUCT SPEC 108-19276	SIZE A3	RESTRICTED TO -
APPLICATION SPEC 114-19088		CAGE CODE 00779	DRAWING NO C=1982575
WEIGHT -		SCALE 10:1	
CUSTOMER DRAWING		SHEET 1 OF 5 REV A1	

THIS DRAWING IS UNPUBLISHED. RELEASED FOR PUBLICATION
 © COPYRIGHT - BY TYCO ELECTRONICS CORPORATION. ALL RIGHTS RESERVED.

LOC	DIST	REVISIONS			
P	LTR	DESCRIPTION	DATE	DWN	APVD
H	-	SEE SHEET 1	-	-	-

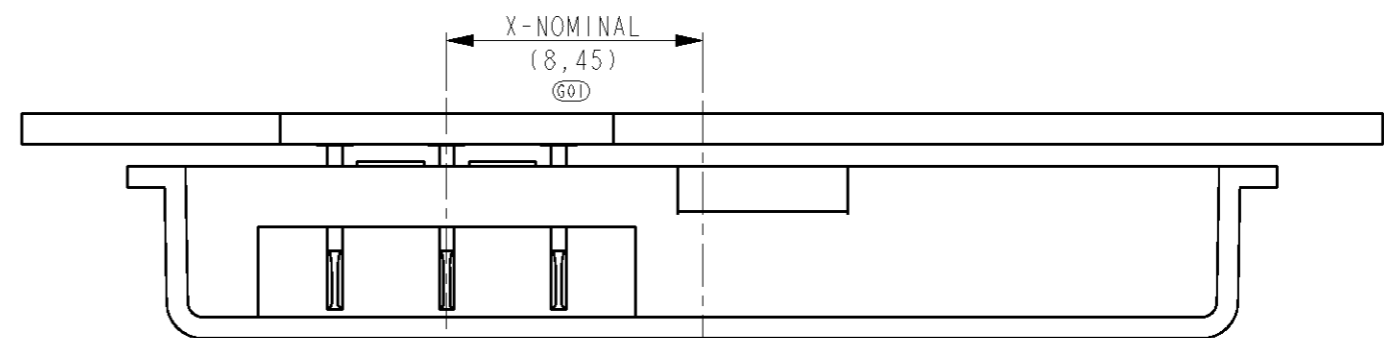
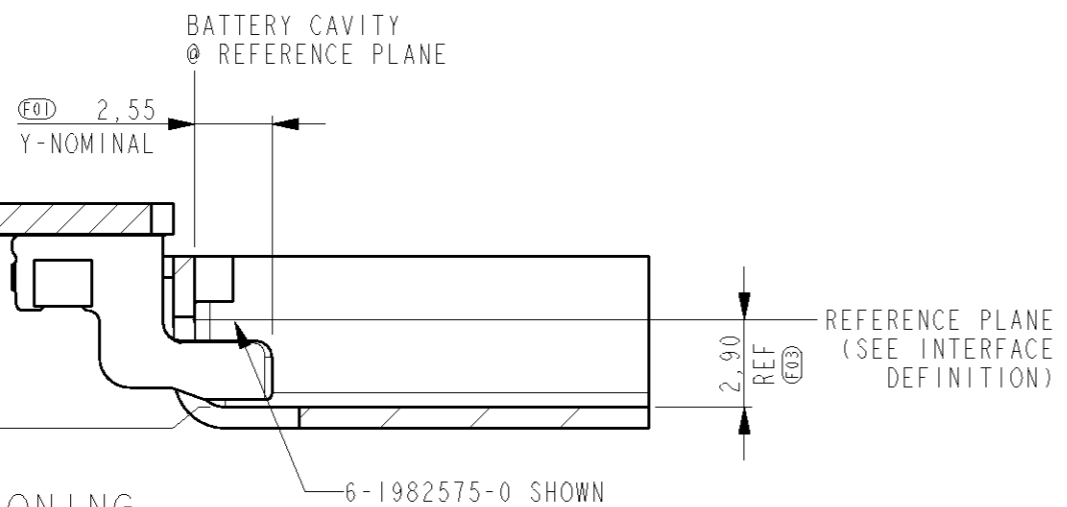
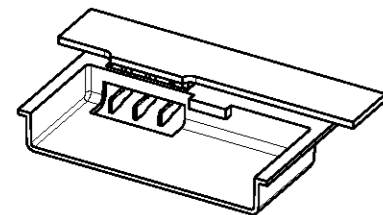

SITUATION SKETCH OF THE PLUG APPLIED IN A BL-4B PHONE CASE.

CONNECTOR POSITIONING

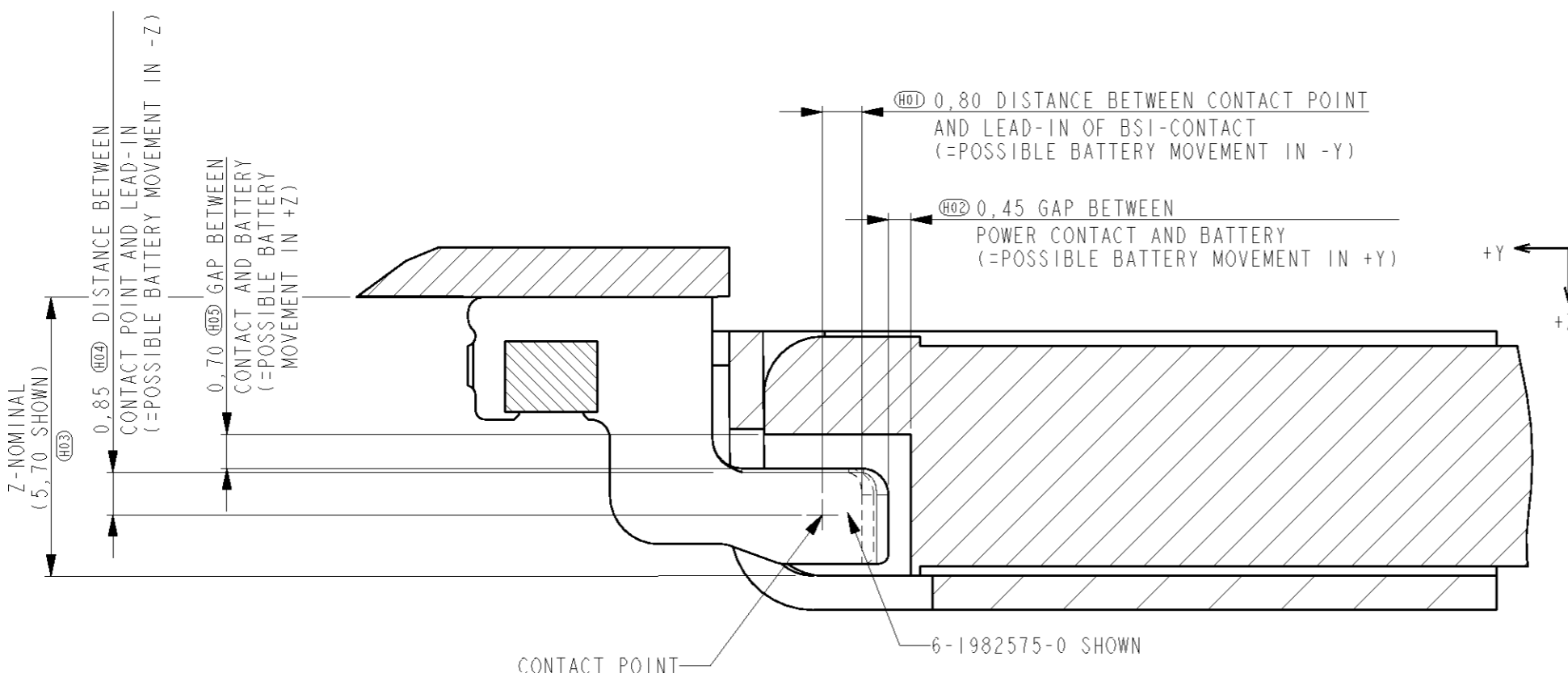

WORKING RANGE:
 (PERMITTED BATTERY MOVEMENT)

IN X-DIRECTION ±0,50 SYMMETRICAL

IN Y-DIRECTION 1,25 TOTAL
 IN -Y-DIRECTION 0,80
 (BATTERY LENGTH TOLERANCE, PHONE CASE TOLERANCE, ASSEMBLY TOLERANCE, PHONE FLEXIBILITY)
 IN +Y-DIRECTION 0,45
 (ASSEMBLY TOLERANCE, PHONE FLEXIBILITY)

IN Z-DIRECTION 1,55 TOTAL
 IN -Z-DIRECTION 0,85
 (BATTERY FRONT TOLERANCE, PHONE CASE TOLERANCE, PHONE FLEXIBILITY)
 IN +Z-DIRECTION 0,70
 (PHONE CASE TOLERANCE, PHONE FLEXIBILITY)
 THESE VALUES APPLY IF Z-NOMINAL IS IN THE CENTER OF THE RANGE SPECIFIED FOR THE PLUG (AS SHOWN HERE).

WORKING RANGE

SCALE 8:1

<small>THIS DRAWING IS A CONTROLLED DOCUMENT FOR TYCO ELECTRONICS CORPORATION IT IS SUBJECT TO CHANGE AND THE CONTROLLING ENGINEERING ORGANIZATION SHOULD BE CONTACTED FOR THE LATEST REVISION.</small>		DWN P.Willems 16-MAY-07 CHK H.d.Otter 16-MAY-07 APVD D.Halberstadt 16-MAY-07	Tyco Electronics TYCO ELECTRONICS NEDERLAND B.V. 's-HERTOGENBOSCH, THE NETHERLANDS	
DIMENSIONS: mm 		PRODUCT SPEC 108-19276 APPLICATION SPEC 114-19088 WEIGHT -	NAME PLUG CONNECTOR ATB-TYPE, 3 POSITION BATTERY BLOCK	
TOLERANCES UNLESS OTHERWISE SPECIFIED: 0 PLC ±- 1 PLC ±0,2 2 PLC ±0,1 3 PLC ±- 4 PLC ±- ANGLES ±-		CUSTOMER DRAWING	SIZE A3 CAGE CODE 00779 DRAWING NO. 1982575	RESTRICTED TO -
MATERIAL - FINISH -		SCALE 10:1	SHEET 2 OF 5	REV A

THIS DRAWING IS UNPUBLISHED. RELEASED FOR PUBLICATION
 © COPYRIGHT - BY TYCO ELECTRONICS CORPORATION. ALL RIGHTS RESERVED.

LOC	DIST	REVISIONS					
H	-	P	LTR	DESCRIPTION	DATE	DWN	APVD
			-	SEE SHEET 1	-	-	-

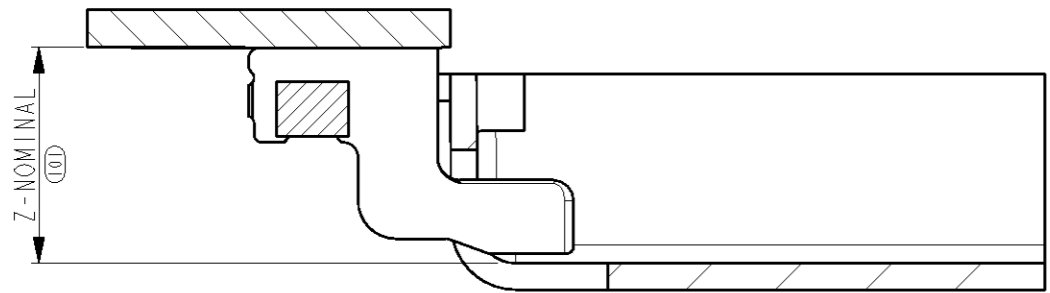

NMP CODE	PART NUMBER	Z-NOMINAL RANGE	DIMENSION "A"	MASS [mg]
---	3-1982575-0	<3,0 (2,50 - 2,90)	0,50	
---	3-1982575-5	<3,5 (3,00 - 3,40)	1,00	
---	4-1982575-0	<4,0 (3,50 - 3,90)	1,50	
---	4-1982575-5	<4,5 (4,00 - 4,40)	2,00	
---	5-1982575-0	<5,0 (4,50 - 4,90)	2,50	
---	5-1982575-5	<5,5 (5,00 - 5,40)	3,00	
5469228	6-1982575-0	<6,0 (5,50 - 5,90)	3,50	372

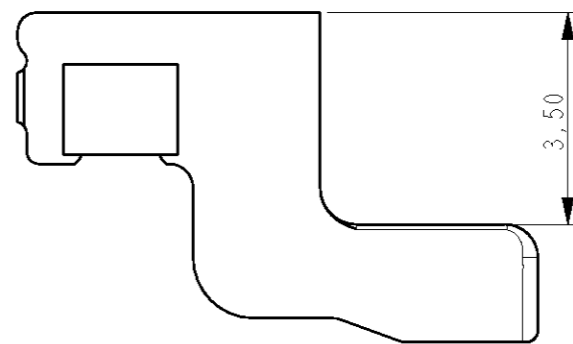

6-1982575-0

PRODUCT SELECTION

<small>THIS DRAWING IS A CONTROLLED DOCUMENT FOR TYCO ELECTRONICS CORPORATION. IT IS SUBJECT TO CHANGE AND THE CONTROLLING ENGINEERING ORGANIZATION SHOULD BE CONTACTED FOR THE LATEST REVISION.</small>		DWN P.Willems 16-MAY-07 CHK H.d.Otter 16-MAY-07 APVD D.Halberstadt 16-MAY-07		Tyco Electronics TYCO ELECTRONICS NEDERLAND B.V. 's-HERTOGENBOSCH, THE NETHERLANDS	
DIMENSIONS: mm 		TOLERANCES UNLESS OTHERWISE SPECIFIED: 0 PLC ±- 1 PLC ±0,2 2 PLC ±0,1 3 PLC ±- 4 PLC ±- ANGLES ±-		NAME PLUG CONNECTOR ATB-TYPE, 3 POSITION BATTERY BLOCK	
MATERIAL - FINISH -		PRODUCT SPEC 108-19276 APPLICATION SPEC 114-19088 WEIGHT -		SIZE A3 CAGE CODE 00779 DRAWING NO C=1982575 RESTRICTED TO -	
CUSTOMER DRAWING				SCALE 10:1 SHEET 3 OF 5 REV A	

THIS DRAWING IS UNPUBLISHED. RELEASED FOR PUBLICATION
 © COPYRIGHT - BY TYCO ELECTRONICS CORPORATION. ALL RIGHTS RESERVED.

LOC	DIST	REVISIONS					
		P	LTR	DESCRIPTION	DATE	DWN	APVD
H	-	-	-	SEE SHEET 1	-	-	-

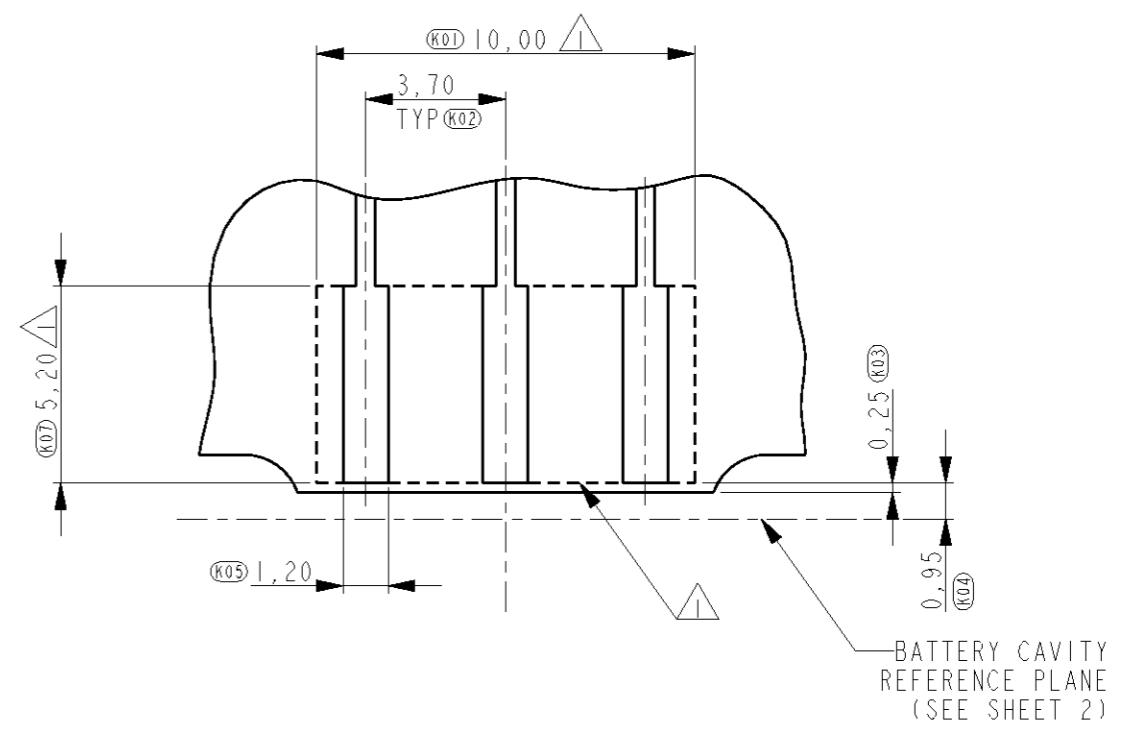
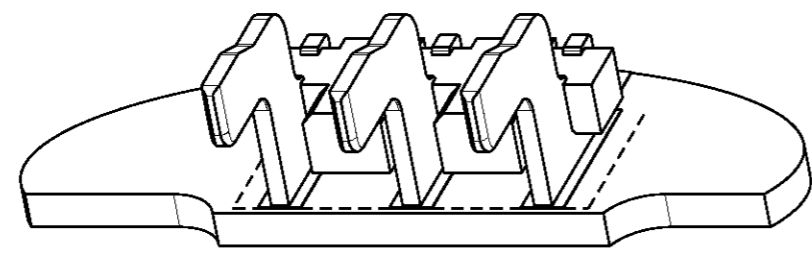
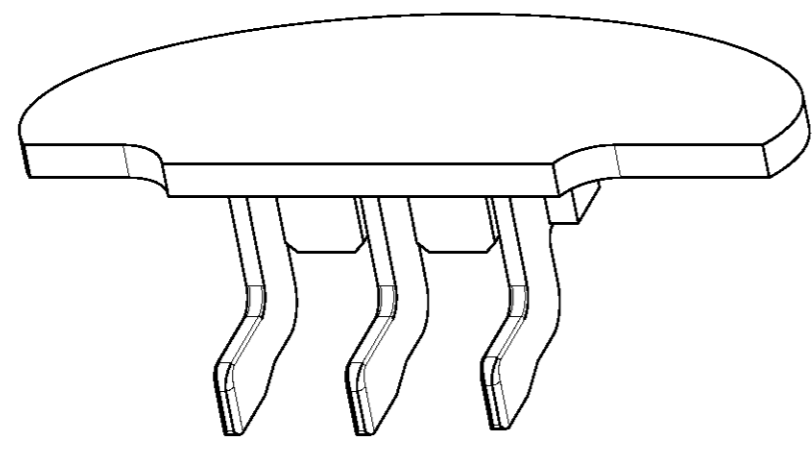

NOTES:
 △ AREA FREE OF SOLDER SCREEN.

THIS DRAWING IS A CONTROLLED DOCUMENT FOR TYCO ELECTRONICS CORPORATION. IT IS SUBJECT TO CHANGE AND THE CONTROLLING ENGINEERING ORGANIZATION SHOULD BE CONTACTED FOR THE LATEST REVISION.		DWN P. Willems 16-MAY-07	TYCO ELECTRONICS NEDERLAND B.V. 's-HERTOGENBOSCH, THE NETHERLANDS	
DIMENSIONS: mm		CHK H.d.Otter 16-MAY-07	NAME PLUG CONNECTOR ATB-TYPE, 3 POSITION BATTERY BLOCK	
TOLERANCES UNLESS OTHERWISE SPECIFIED: 0 PLC ±- 1 PLC ±0,2 2 PLC ±0,1 3 PLC ±- 4 PLC ±- ANGLES ±-		APVD D. Halberstadt 16-MAY-07	PRODUCT SPEC 108-19276	
MATERIAL -		FINISH -	APPLICATION SPEC 114-19088	RESTRICTED TO -
		WEIGHT -	SIZE A3	CAGE CODE 00779
		CUSTOMER DRAWING	DRAWING NO C=1982575	SCALE 10:1
			SHEET 4	OF 5
			REV A	

THIS DRAWING IS UNPUBLISHED. RELEASED FOR PUBLICATION

© COPYRIGHT - BY TYCO ELECTRONICS CORPORATION. ALL RIGHTS RESERVED.

LOC	DIST	REVISIONS			
P	LTR	DESCRIPTION	DATE	DWN	APVD
H	-	SEE SHEET 1	-	-	-

PART NUMBER	QUANTITY PER REEL	DIMENSION "D"
6-1982575-0	800	5,75

NOTES:

1 REEL DIMENSION: 330x101x24,4.

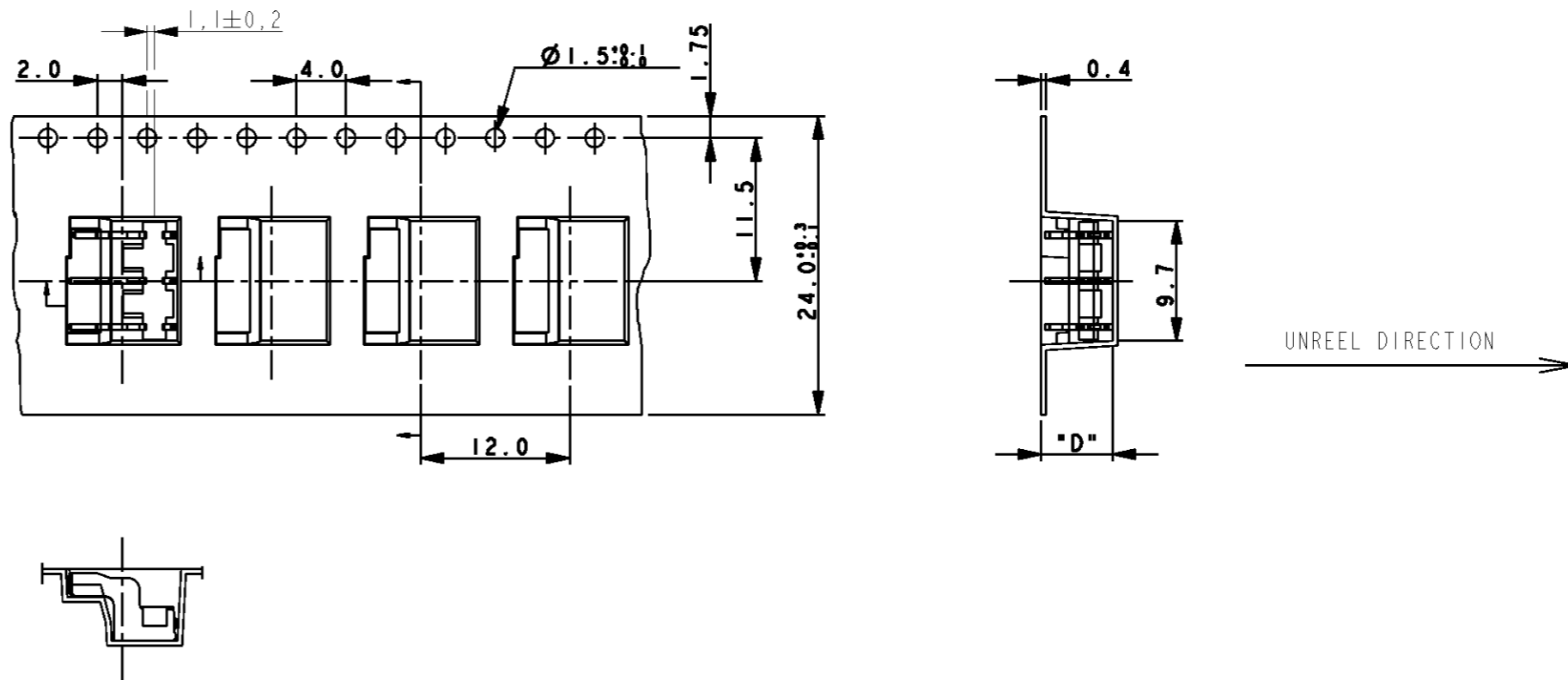

<small>THIS DRAWING IS A CONTROLLED DOCUMENT FOR TYCO ELECTRONICS CORPORATION IT IS SUBJECT TO CHANGE AND THE CONTROLLING ENGINEERING ORGANIZATION SHOULD BE CONTACTED FOR THE LATEST REVISION.</small>		DWN P. Willems 16-MAY-07 CHK H. d. Otter 16-MAY-07 APVD D. Halberstadt 16-MAY-07		TYCO ELECTRONICS NEDERLAND B.V. 's-HERTOGENBOSCH, THE NETHERLANDS	
DIMENSIONS: mm		TOLERANCES UNLESS OTHERWISE SPECIFIED: 0 PLC ±- 1 PLC ±0,2 2 PLC ±0,1 3 PLC ±- 4 PLC ±- ANGLES ±-		NAME PLUG CONNECTOR ATB-TYPE, 3 POSITION BATTERY BLOCK	
		PRODUCT SPEC 108-19276		SIZE CAGE CODE DRAWING NO RESTRICTED TO A3 00779 C-1982575 -	
MATERIAL -		FINISH -		APPLICATION SPEC 114-19088	
CUSTOMER DRAWING				SCALE 10:1 SHEET 5 OF 5 REV A	

单击下面可查看定价，库存，交付和生命周期等信息

[>>TE Connectivity\(泰科\)](#)