

PART NUMBER	REVISION	DESCRIPTION	FEED TYPE
2266673-1	J	FINE CRIMP HEIGHT ADJUST	MECHANICAL
2266673-2	K	FINE CRIMP HEIGHT ADJUST	PNEUMATIC
3-2266673-2	K	FINE CRIMP HEIGHT ADJUST	DOUBLE ACTING PNEUMATIC WITH SENSORS
7-2266673-1	J	MECHANICAL AND CRIMP TOOLING KIT	MECHANICAL
7-2266673-2	K	PNEUMATIC AND CRIMP TOOLING KIT	PNEUMATIC
7-2266673-7	F	CRIMP TOOLING KIT	-

ATLANTIC VERSION TERMINATOR INTERFACE ADAPTER

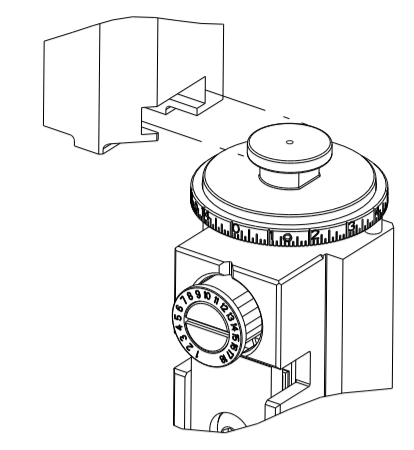

APPLICATOR DATA		
CRIMP	SIZE	TYPE
WIRE	1.07 mm [.042]	F
INSUL	1.55 mm [.061]	O

APPLICATOR INSTRUCTIONS			
408-35042			
TERMINAL DATA: TE TERMINAL		TE CRIMP SPECIFICATION	
TERMINAL NAME: CONTACT, MALE, GENERATION Y, 0.64			
WIRE STRIP LENGTH		INSULATION DIAMETER RANGE	
4.00-4.50 mm [1.57-.177 IN]		Ø1.10-1.40 mm [.043-.055 IN]	
TERMINAL APPLICATION SPECIFICATION		114-13183	
TERMINALS APPLIED			
TE TERMINAL	TE TERMINAL	TE TERMINAL	TE TERMINAL
1924968-8	1-2035334-8	1-1456574-8	1-2138699-4
1924955-8	1-1924727-4	2098762-4	1-2138699-8
1-1924955-8	2035170-4	1456968-8	1-2098753-4
1-1456841-8	1-2035170-4	1-1456968-4	
2035334-8	1924275-8	1-1456968-8	

WIRE SIZE	CRIMP HEIGHT mm [INCH]	CRIMP HEIGHT REFERENCE SETTING
0.35mm2 OR 22 AWG	0.91+/-0.03 [.036+/-0.001]	8.8

- RECOMMENDED SPARE PARTS
- REFER TO SUPPLIED INSTRUCTION SHEET FOR CLEANING, LUBRICATION AND STORAGE OF APPLICATOR.
- APPLY PART NUMBER 2-23419-6 LOCTITE TO THREADS OF ITEM 242.
- CRIMP HEIGHT REFERENCE SETTING WAS THE SETTING USED WHEN THE APPLICATOR WAS QUALIFIED AT THE FACTORY. ADJUSTMENT MAY BE NECESSARY WHEN RUNNING APPLICATOR IN THE FIELD.
- TERMINAL LUBRICANT IS RECOMMENDED.
- UNLESS SPECIFIED OTHERWISE TORQUE VALUES SHALL BE USED PER DOCUMENT, 101-35000.
- THIS APPLICATOR HAS BEEN DESIGNED TO APPLY WIRES WITH THIN WALL (FLR) INSULATION.
- DIMENSION 1.0±0.5 ON TERMINAL SUPPORT VIEW APPLIES TO ALL SOCKET TERMINALS.
- DIMENSION 4.2±0.5 ON TERMINAL SUPPORT VIEW APPLIES TO ALL PIN TERMINALS.
- THIS APPLICATOR IS EQUIPPED WITH THE DOUBLE ACTING PNEUMATIC FEED WITH SENSORS, AND IS APPLICATION SPECIFIC AND DOES NOT REQUIRE ITEMS 49 & 248.

***WARNING**
ON INSTALLATION, SET WIRE DISC TO CRIMP HEIGHT REFERENCE SETTING FOR LARGEST WIRE SIZE. CRIMP HEIGHT REFERENCE SETTINGS GREATER THAN THE VALUE SHOWN MAY CAUSE DAMAGE TO THE CRIMP TOOLING. REFER TO THE INSTRUCTION SHEET FOR PROPER SETUP AND ADJUSTMENTS.

LOC	DIST	REVISIONS			
P	LTN	DESCRIPTION	DATE	OWN	APVD
J		ECR-18-005223	14APR2018	TB	JDG
J1		ECR-18-011311	17JUL2018	MZ	KZ
K		ECR-19-005438	04APR2019	LG	TE
K1		ECR-21-006819	12JUL2021	FJ	YY

-	-	-	1	-	-	2844950-1	AIR FEED MODULE	290
-	1	-	-	1	-	2119641-1	FEED CAM, AIR FEED	248
-	1	1	1	1	1	2119082-5	CAM, SNAIL, INSULATION ADJUSTMENT	244
-	1	1	1	1	1	2079764-1	WASHER, WAVE SPRING, CREST-TO-CREST	243
-	1	1	1	1	1	2119083-1	RETAINER, INSULATION DIAL	242
-	1	1	1	1	1	7-18023-7	SCR, SKT HD CAP M3 X 4.0	241
-	-	1	-	-	1	2119580-1	MECHANICAL FEED ASSEMBLY	239
-	1	-	-	-	1	2844940-1	AIR FEED MODULE	238
-	REF	REF	REF	REF	REF	994970-2	COUNTER, MAGNETIC	164
-	1	1	1	1	1	1-18028-2	WASHER, FLAT, REG M4	119
-	1	1	1	1	1	2119955-1	ASSY, LUBRICATOR, SIDE FEED	113
-	1	1	1	1	1	2844908-1	SCREW, LOCKING	99
-	1	1	1	1	1	2844907-1	POST, LOCKING	98
-	1	1	1	1	1	455888-4	SPACER, CRIMPER	82
-	1	1	1	1	1	1803607-3	DOCUMENTATION PACKAGE	71
-	1	1	1	1	1	2119791-9	DEPRESSOR, WIRE	70
-	1	1	1	1	1	2119740-1	TAG IDENTIFICATION	67
-	2	2	2	2	2	2168078-1	SCREW, DRIVE, RH, RoHS, 2 x .188	66
-	1	1	1	1	1	2168083-2	SCR, SKT HD CAP, RoHS, M4 X 8.0	60
-	1	1	1	1	1	5-18022-5	SCR, HEX HD CAP, M4 X 6.0	59
-	1	1	1	1	1	1338685-1	PAWL, FEED	56
-	4	4	4	4	4	2168083-3	SCR, SKT HD CAP, RoHS, M4 X 12.0	54
-	2	2	2	2	2	1-2168083-0	SCR, SKT HD CAP, RoHS, M4 X 10	53
-	1	1	1	1	1	5018030-1	NUT, HEX, REG, RoHS, M3	52
-	1	1	1	1	1	811242-5	BUMPER, HOLD DOWN	51
-	1	1	1	1	1	690753-2	SPACER, TONKER	50
-	1	2	-	1	2	18023-9	SCR, SKT HD CAP M4 X 6.0	49
-	-	-	1	-	-	2119652-1	FEED CAM, PRE FEED	48
-	-	-	-	-	1	2119653-1	FEED CAM, POST FEED	47
-	1	1	1	1	1	1803583-9	APPLICATOR BASIC ASSEMBLY, SF	46
-	1	1	1	1	1	1803515-1	RAM ASSEMBLY, SF ATLANTIC	44
-	1	1	1	1	1	1803602-1	SCR, BHSC, RoHS (M8 X 25)	41
-	1	1	1	1	1	6-1752356-2	SUPPORT, TERMINAL	34
-	2	2	2	2	2	2079383-5	SCR, BHSC, RoHS (M4 X 20)	33
-	2	2	2	2	2	2-2844962-4	SPACER, CYLINDRICAL, STRIP GUIDE	30
-	1	1	1	1	1	2844992-4	ASSEMBLY, STRIP GUIDE	29
-	1	1	1	1	1	240792-1	DRAG, TERMINAL	25
-	1	1	1	1	1	1320928-2	STRIP GUIDE	24
-	1	1	1	1	1	2168083-2	SCR, SKT HD CAP, RoHS, M4 X 8.0	21
-	1	1	1	1	1	1-18028-2	WASHER, FLAT, REG M4	20
-	1	1	1	1	1	2119533-1	STRIPPER, SIDE FEED	19
-	1	1	1	1	1	2119806-1	INSERT, SHEAR	13
-	1	1	1	1	1	3-22280-3	SPRING, COMPRESSION	12
-	1	1	1	1	1	1-356885-4	STOP, SHEAR	11
-	1	1	1	1	1	2119805-1	SHEAR HOLDER, FRONT	10
-	1	1	1	1	1	1803095-6	FLOATING SHEAR, FRONT	9
-	1	2	2	1	1	1-1803058-6	ANVIL, COMBINATION	8
-	-	-	-	-	-	-	-	7
-	-	-	-	-	-	-	-	6
-	1	1	1	1	1	2119757-3	DEPRESSOR, SHEAR	5
-	1	1	1	1	1	3-238011-1	BLOCK, CRIMPER SPACER	4
-	1	2	2	1	1	1-1803019-1	CRIMPER, INSULATION O	3
-	1	1	1	1	1	455888-3	SPACER, CRIMPER	2
-	1	2	2	1	1	8-1633860-6	CRIMPER, WIRE	1

ATLANTIC VERSION
Shown on sheets 1 of 4 & 2 of 4
(Pacific version shown on sheets 3 of 4 & 4 of 4)

DIMENSIONS:		TOLERANCES UNLESS OTHERWISE SPECIFIED:		MATERIAL:		FINISH:		WEIGHT:		SCALE:		SHEET:		REV:	
mm	0 PLC ±	1 PLC ±	2 PLC ±	3 PLC ±	4 PLC ±	ANGLES	FINISH			A1	00779	2266673	1	4	K1

LOC	DIST	REVISIONS			
A	66	REV	DATE	BY	APPD
-	SEE SHEET 1	-	-	-	-

FEED TYPE MECHANICAL

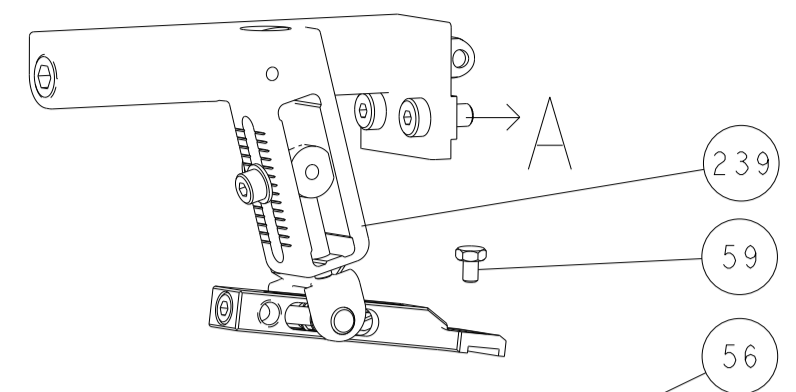

PNEUMATIC

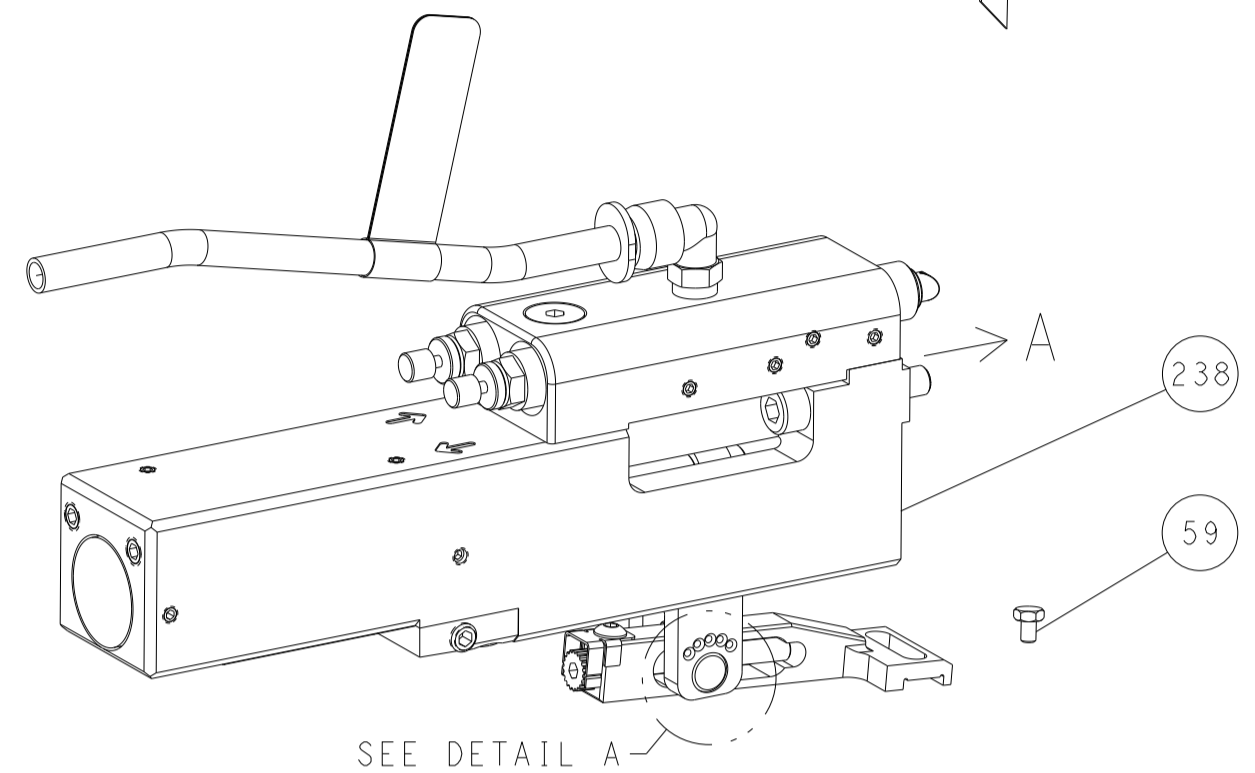

FEED SPRING SETTING POSITION (SHOWN FROM REAR SIDE)

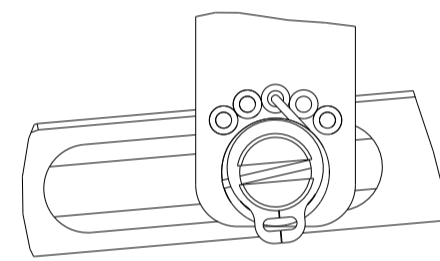

DETAIL A

DOUBLE ACTING PNEUMATIC WITH SENSORS

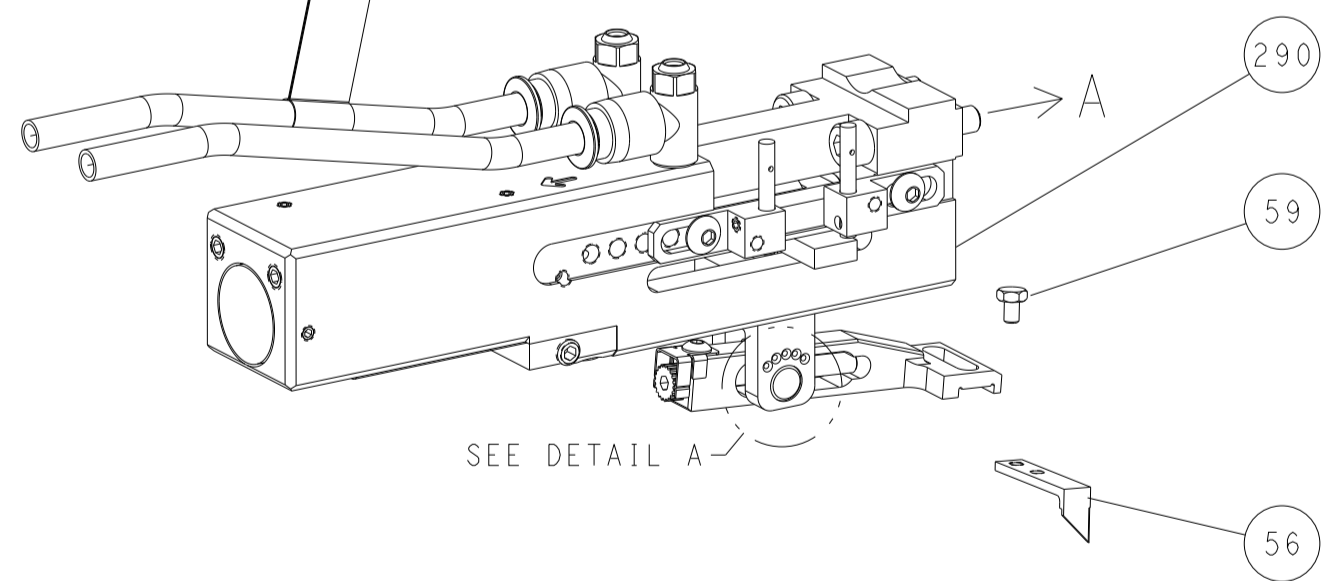

CAM POSITIONS

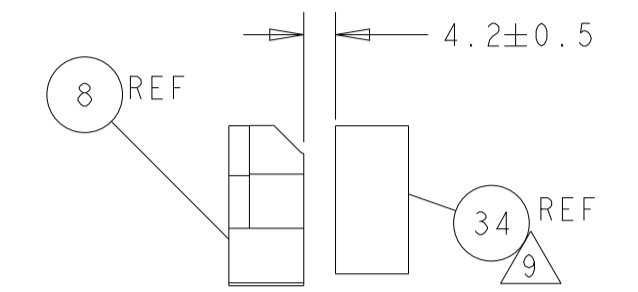
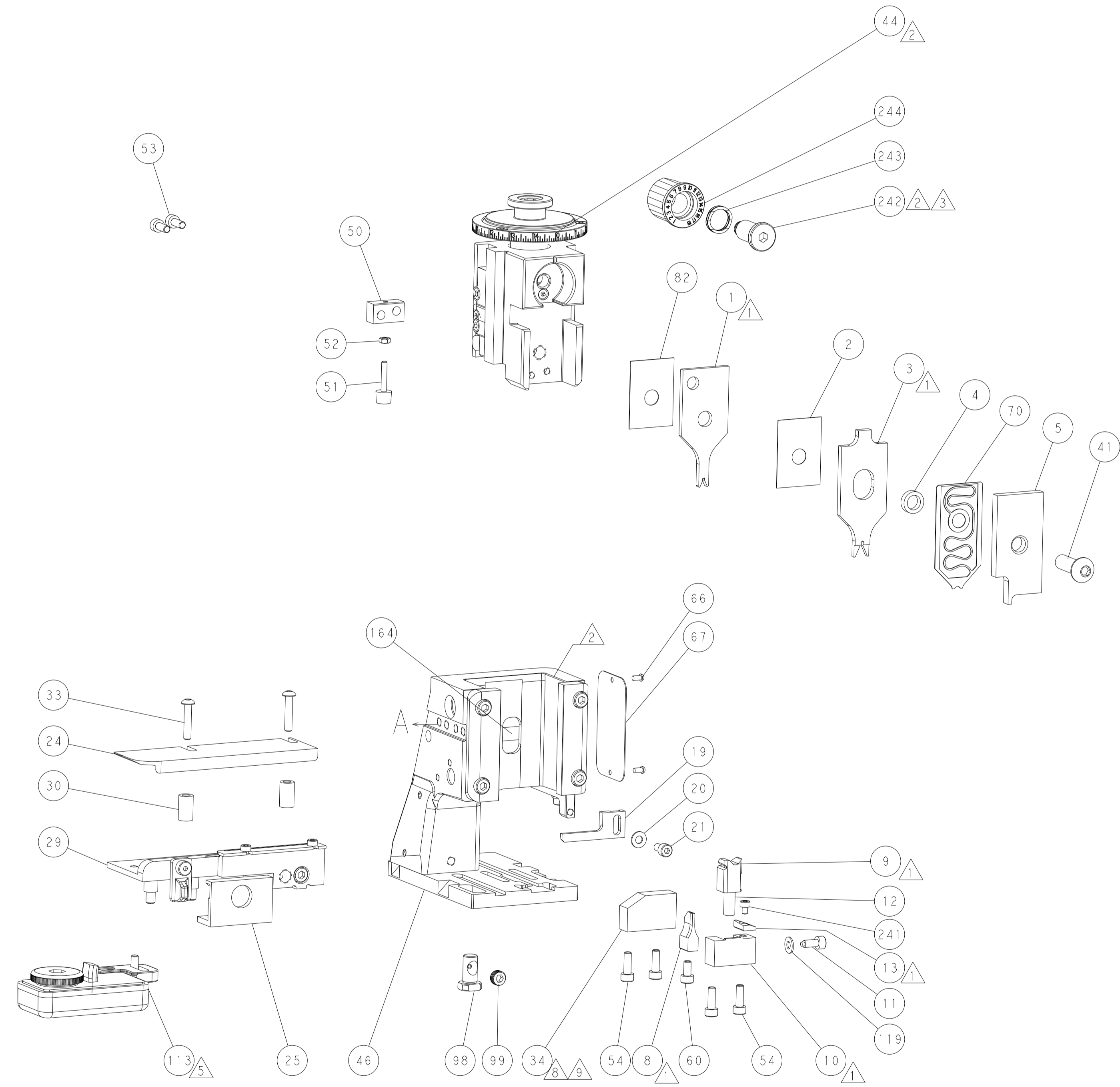
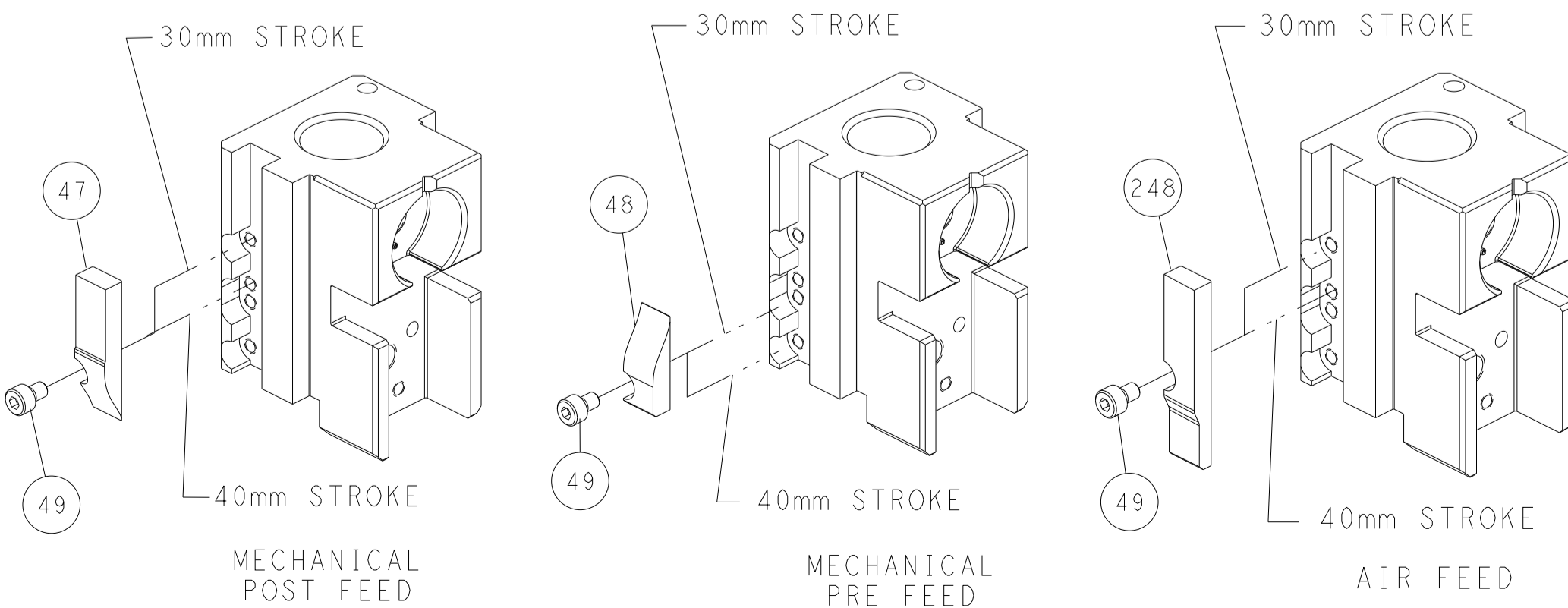

TERMINAL SUPPORT LOCATION FOR ALL PIN TERMINALS

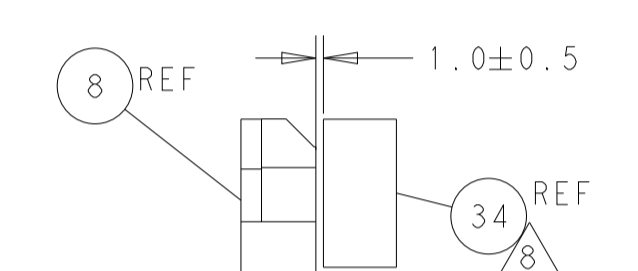

TERMINAL SUPPORT LOCATION FOR ALL SOCKET TERMINALS

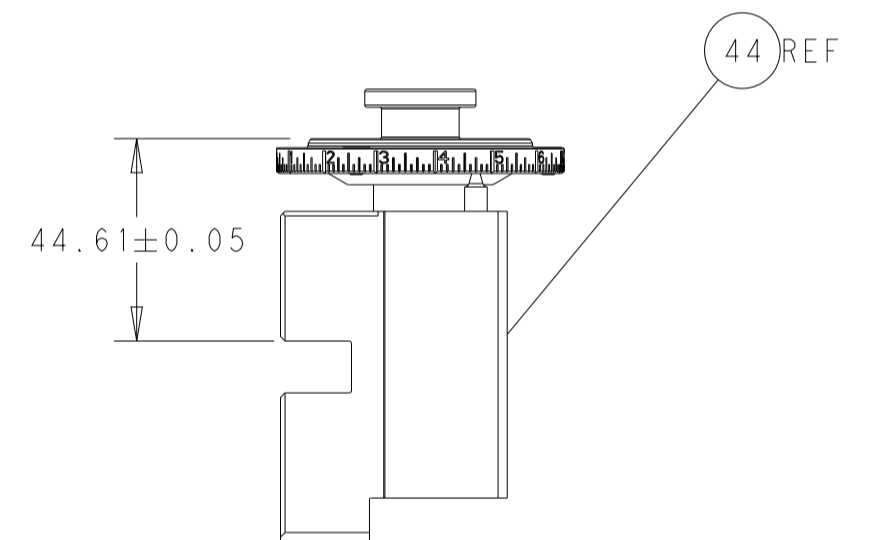

RAM SET-UP

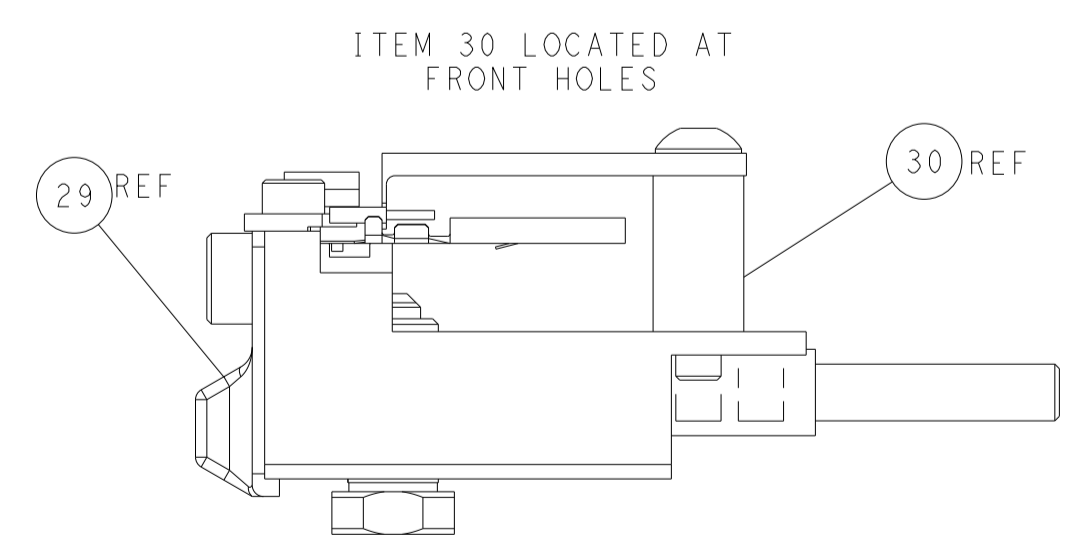

FEED TRACK POSITION GUIDE BY INSULATION BARREL

ATLANTIC VERSION
 Shown on sheets 1 of 4 & 2 of 4
 (Pacific version shown on sheets 3 of 4 & 4 of 4)

DIMENSIONS: mm 		TOLERANCES UNLESS OTHERWISE SPECIFIED: 0 PLC ± 1 PLC ± 2 PLC ± 3 PLC ± 4 PLC ± ANGLES ± FINISH ±		DWN J. HOU 06FEB2015 CHK L. ZHANG 06FEB2015 APVD U. GUO 06FEB2015 PRODUCT SPEC APPLICATION SPEC WEIGHT SCALE 1:2		NAME Ocean Side Feed Applicator SIZE CAGE CODE DRAWING NO. RESTRICTED TO A1 00779 ©=2266673 SHEET 2 OF 4 REV K1	
MATERIAL:				Customer Accessible Production Drawing			

PART NUMBER	REVISION	DESCRIPTION	FEED TYPE
2-2266673-1	J	FINE CRIMP HEIGHT ADJUST	MECHANICAL
2-2266673-2	K	FINE CRIMP HEIGHT ADJUST	PNEUMATIC
4-2266673-2	K	FINE CRIMP HEIGHT ADJUST	DOUBLE ACTING PNEUMATIC WITH SENSORS
7-2266673-7	F	CRIMP TOOLING KIT	-

PACIFIC VERSION TERMINATOR INTERFACE ADAPTER

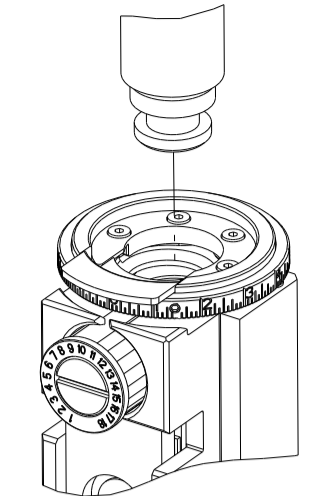

APPLICATOR DATA

CRIMP	SIZE	TYPE
WIRE	1.07 mm [.042]	F
INSUL	1.55 mm [.061]	O

APPLICATOR INSTRUCTIONS
408-35042

TERMINAL DATA: TE TERMINAL TE CRIMP SPECIFICATION

TERMINAL NAME: CONTACT, MALE, GENERATION Y, 0.64

WIRE STRIP LENGTH	INSULATION DIAMETER RANGE
4.00-4.50 mm [1.57-.177 IN]	Ø1.10-1.40 mm [.043-.055 IN]

TERMINAL APPLICATION SPECIFICATION 114-13183

TERMINALS APPLIED

TE TERMINAL	TE TERMINAL	TE TERMINAL	TE TERMINAL
1924968-8	1-2035334-8	1-1456574-8	1-2138699-4
1924955-8	1-1924727-4	2098762-4	1-2138699-8
1-1924955-8	2035170-4	1456968-8	1-2098753-4
1-1456841-8	1-2035170-4	1-1456968-4	
2035334-8	1924275-8	1-1456968-8	

WIRE SIZE	CRIMP HEIGHT mm [INCH]	CRIMP HEIGHT REFERENCE SETTING
0.35mm2 OR 22 AWG	0.91+/-0.03 [.036+/-0.001]	8.8

- 1 RECOMMENDED SPARE PARTS
- 2 REFER TO SUPPLIED INSTRUCTION SHEET FOR CLEANING, LUBRICATION AND STORAGE OF APPLICATOR.
- 3 APPLY PART NUMBER 2-23419-6 LOCTITE TO THREADS OF ITEM 242.
- 4 CRIMP HEIGHT REFERENCE SETTING WAS THE SETTING USED WHEN THE APPLICATOR WAS QUALIFIED AT THE FACTORY. ADJUSTMENT MAY BE NECESSARY WHEN RUNNING APPLICATOR IN THE FIELD.
- 5 TERMINAL LUBRICANT IS RECOMMENDED.
- 6 UNLESS SPECIFIED OTHERWISE TORQUE VALUES SHALL BE USED PER DOCUMENT, 101-35000.
- 7 THIS APPLICATOR HAS BEEN DESIGNED TO APPLY WIRES WITH THIN WALL (FLR) INSULATION.
- 8 DIMENSION 1.0±0.5 ON TERMINAL SUPPORT VIEW APPLIES TO ALL SOCKET TERMINALS.
- 9 DIMENSION 4.2±0.5 ON TERMINAL SUPPORT VIEW APPLIES TO ALL PIN TERMINALS.
- 10 THIS APPLICATOR IS EQUIPPED WITH THE DOUBLE ACTING PNEUMATIC FEED WITH SENSORS, AND IS APPLICATION SPECIFIC AND DOES NOT REQUIRE ITEMS 49 & 151.

***WARNING**
ON INSTALLATION, SET WIRE DISC TO CRIMP HEIGHT REFERENCE SETTING FOR LARGEST WIRE SIZE. CRIMP HEIGHT REFERENCE SETTINGS GREATER THAN THE VALUE SHOWN MAY CAUSE DAMAGE TO THE CRIMP TOOLING. REFER TO THE INSTRUCTION SHEET FOR PROPER SETUP AND ADJUSTMENTS.

ENTRY LEVEL APPLICATOR ITEM SUBSTITUTION LIST

PART NUMBER	SAME AS	ITEM	ITEM DESCRIPTION	SUBSTITUTE PART NUMBER
8-2266673-1	2266673-1	1	WIRE CRIMPER	8-1803550-6
8-2266673-2	2266673-2	3	INSULATION CRIMPER	1-1803627-1
9-2266673-1	2-2266673-1	46	BASIC SUB -ASSEMBLY	1803940-9
9-2266673-2	2-2266673-2	141	BASIC SUB -ASSEMBLY	1-1803940-0
			LUBRICATOR	DELETE

LOC 66 DIST 66

REV	DATE	DESCRIPTION	DATE	OWN	APVD
-	-	SEE SHEET 1	-	-	-

-	1	-	-	2844950-1	AIR FEED MODULE	290
-	1	1	1	2119082-5	CAM, SNAIL, INSULATION ADJUSTMENT	244
-	1	1	1	2079764-1	WASHER, WAVE SPRING, CREST-TO-CREST	243
-	1	1	1	2119083-1	RETAINER, INSULATION DIAL	242
-	1	1	1	7-18023-7	SCR, SKT HD CAP M3 X 4.0	241
-	-	-	1	2119580-1	MECHANICAL FEED ASSEMBLY	239
-	-	1	-	2844940-1	AIR FEED MODULE	238
-	REF	REF	REF	994970-2	COUNTER, MAGNETIC	164
-	-	1	-	2119641-2	FEED CAM, AIR FEED	151
-	1	1	1	2168083-8	SCR, SKT HD CAP, RoHS, M4 X 16	144
-	4	4	4	2168083-9	SCR, SKT HD CAP, RoHS, M4 X 20	143
-	-	-	1	2119653-2	FEED CAM, POST FEED	142
-	1	1	1	1-1803583-0	APPLICATOR BASIC ASSEMBLY, SF	141
-	1	1	1	1803516-1	RAM ASSEMBLY, SF PACIFIC	140
-	1	1	1	1-18028-2	WASHER, FLAT, REG M4	119
-	1	1	1	2119955-1	ASSY, LUBRICATOR, SIDE FEED	113
-	1	1	1	2844908-1	SCREW, LOCKING	99
-	1	1	1	2844907-1	POST, LOCKING	98
-	1	1	1	455888-4	SPACER, CRIMPER	82
-	1	1	1	1803607-3	DOCUMENTATION PACKAGE	71
-	1	1	1	2119791-9	DEPRESSOR, WIRE	70
-	1	1	1	2119740-1	TAG IDENTIFICATION	67
-	2	2	2	2168078-1	SCREW, DRIVE, RH, RoHS, 2 x .188	66
-	1	1	1	5-18022-5	SCR, HEX HD CAP, M4 X 6.0	59
-	1	1	1	1338685-1	PAWL, FEED	56
-	2	2	2	1-2168083-0	SCR, SKT HD CAP, RoHS, M4 X 10	53
-	1	1	1	5018030-1	NUT, HEX, REG, RoHS, M3	52
-	1	1	1	811242-5	BUMPER, HOLD DOWN	51
-	1	1	1	690753-2	SPACER, TONKER	50
-	-	1	2	18023-9	SCR, SKT HD CAP M4 X 6.0	49
-	-	-	1	2119652-1	FEED CAM, PRE FEED	48
-	1	1	1	1803602-1	SCR, BHSC, RoHS (M8 X 25)	41
-	1	1	1	6-1752356-2	SUPPORT, TERMINAL	34
-	2	2	2	2079383-5	SCR, BHSC, RoHS (M4 X 20)	33
-	2	2	2	2-2844962-4	SPACER, CYLINDRICAL, STRIP GUIDE	30
-	1	1	1	2844992-4	ASSEMBLY, STRIP GUIDE	29
-	1	1	1	240792-1	DRAG, TERMINAL	25
-	1	1	1	1320928-2	STRIP GUIDE	24
-	1	1	1	2168083-2	SCR, SKT HD CAP, RoHS, M4 X 8.0	21
-	1	1	1	1-18028-2	WASHER, FLAT, REG M4	20
-	1	1	1	2119533-1	STRIPPER, SIDE FEED	19
-	1	1	1	2119806-1	INSERT, SHEAR	13
-	1	1	1	3-22280-3	SPRING, COMPRESSION	12
-	1	1	1	1-356885-4	STOP, SHEAR	11
-	1	1	1	2119805-1	SHEAR HOLDER, FRONT	10
-	1	1	1	1803095-6	FLOATING SHEAR, FRONT	9
-	1	1	1	1-1803058-6	ANVIL, COMBINATION	8
-	-	-	-	-	-	7
-	-	-	-	-	-	6
-	1	1	1	2119757-3	DEPRESSOR, SHEAR	5
-	1	1	1	3-238011-1	BLOCK, CRIMPER SPACER	4
-	1	1	1	1-1803019-1	CRIMPER, INSULATION O	3
-	1	1	1	455888-3	SPACER, CRIMPER	2
-	1	1	1	8-1633860-6	CRIMPER, WIRE	1

PACIFIC VERSION
Shown on sheets 3 of 4 & 4 of 4
(Atlantic version shown on sheets 1 of 4 & 2 of 4)

THIS DRAWING IS UNPUBLISHED. RELEASED FOR PUBLICATION 20

TE Connectivity
Harrisburg, PA 17105-3608

Ocean Side Feed
Applicator

Customer Accessible Production Drawing

SCALE 1:2 SHEET 3 OF 4 REV K1

LOC	DIST	REVISIONS					
A	66	P	LTN	DESCRIPTION	DATE	OWN	APVD
		-		SEE SHEET 1			

FEED TYPE MECHANICAL

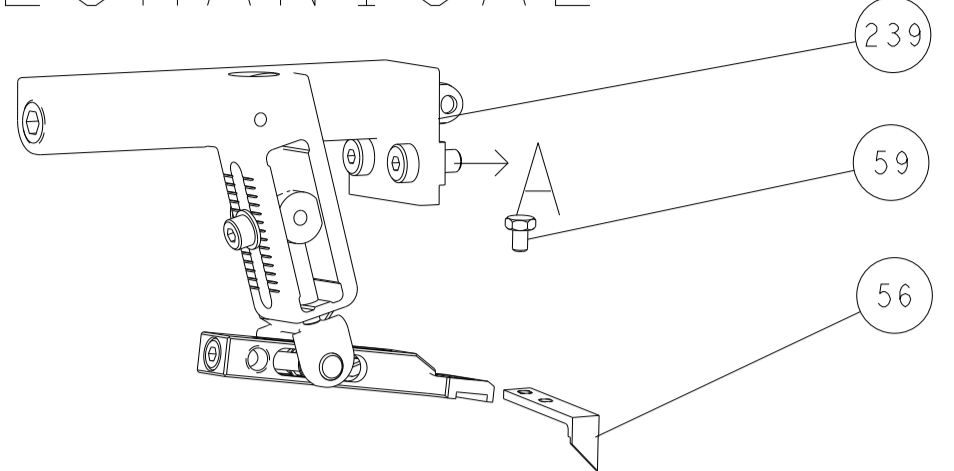

PNEUMATIC

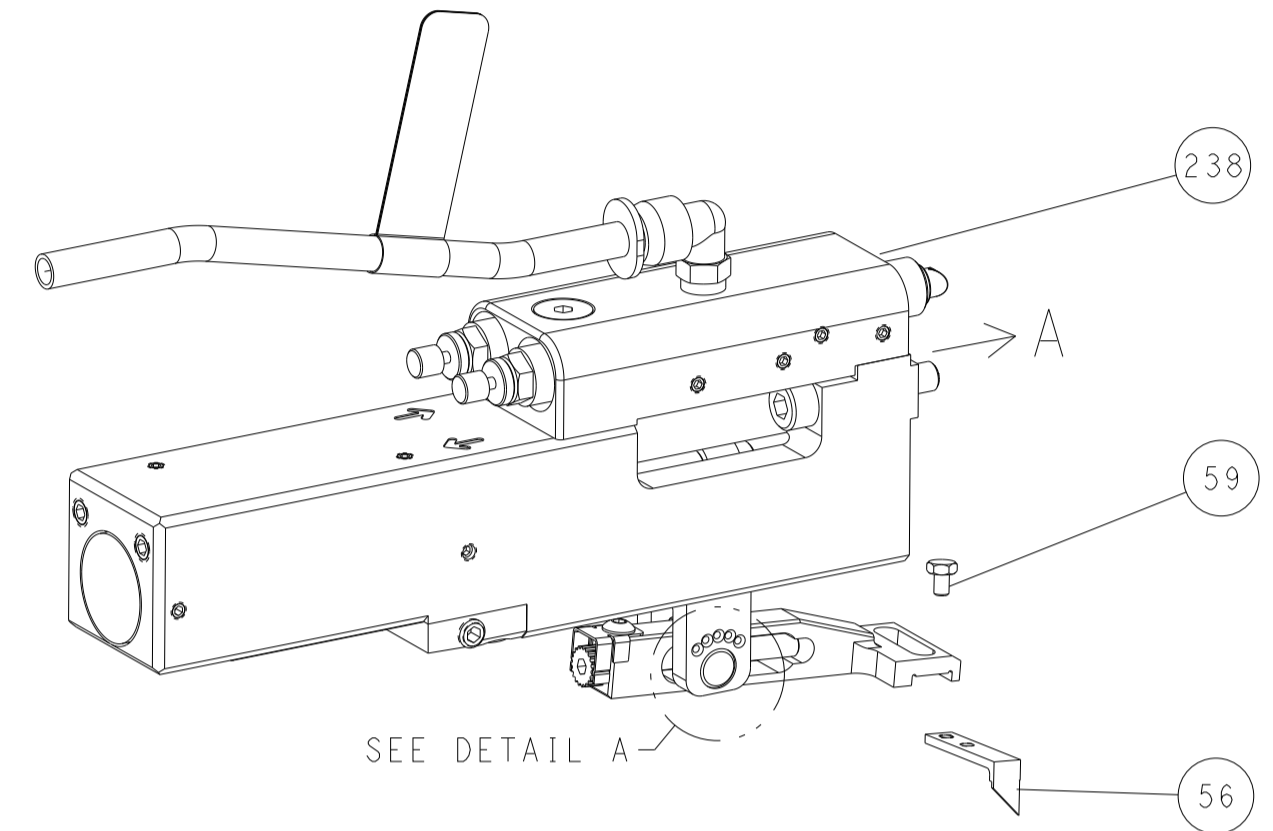

FEED SPRING SETTING POSITION (SHOWN FROM REAR SIDE)

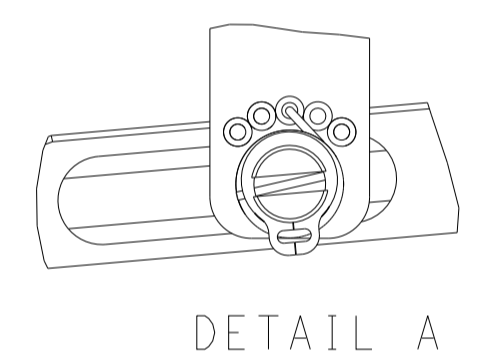

DOUBLE ACTING PNEUMATIC WITH SENSORS

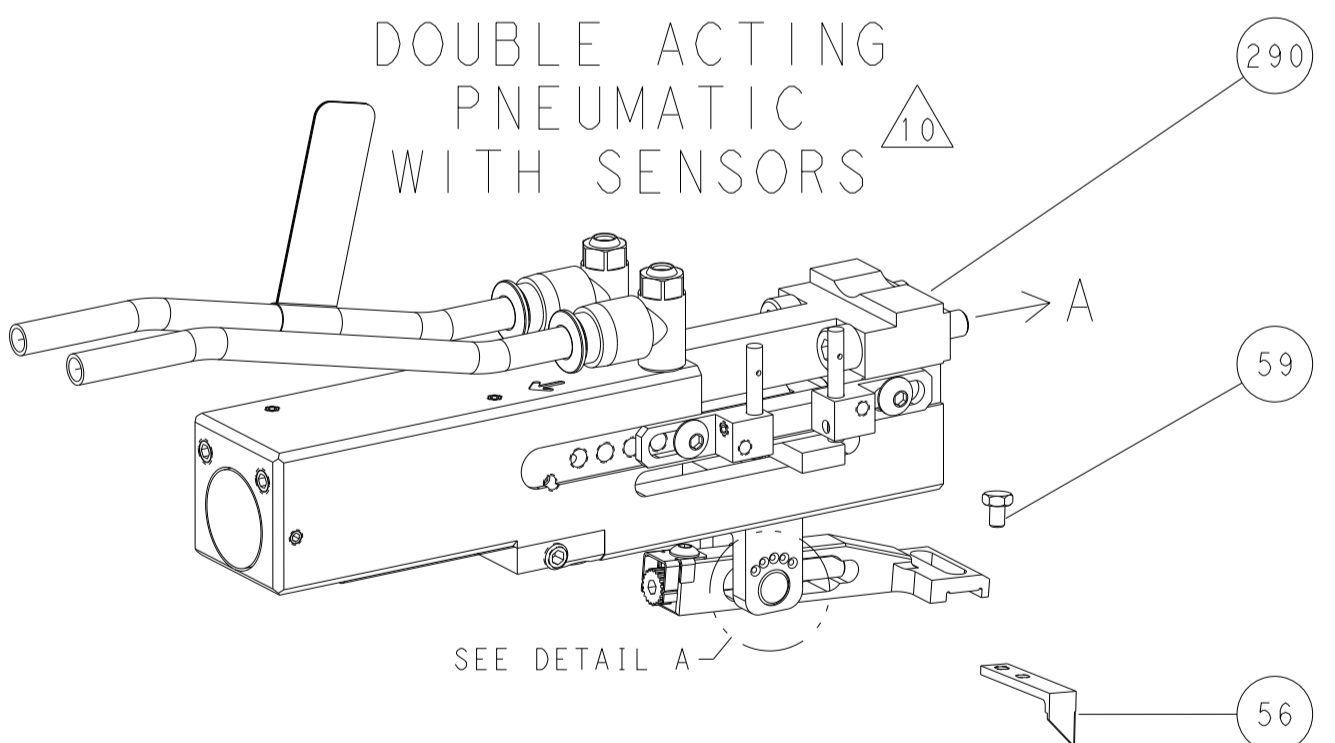

CAM POSITIONS

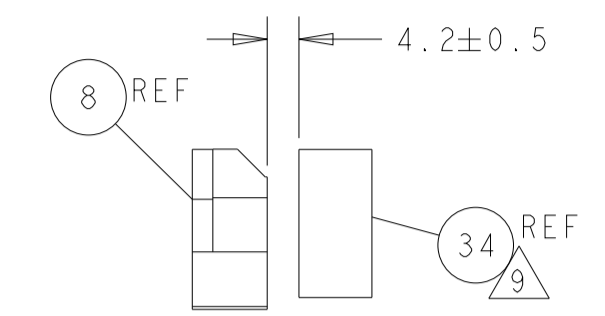
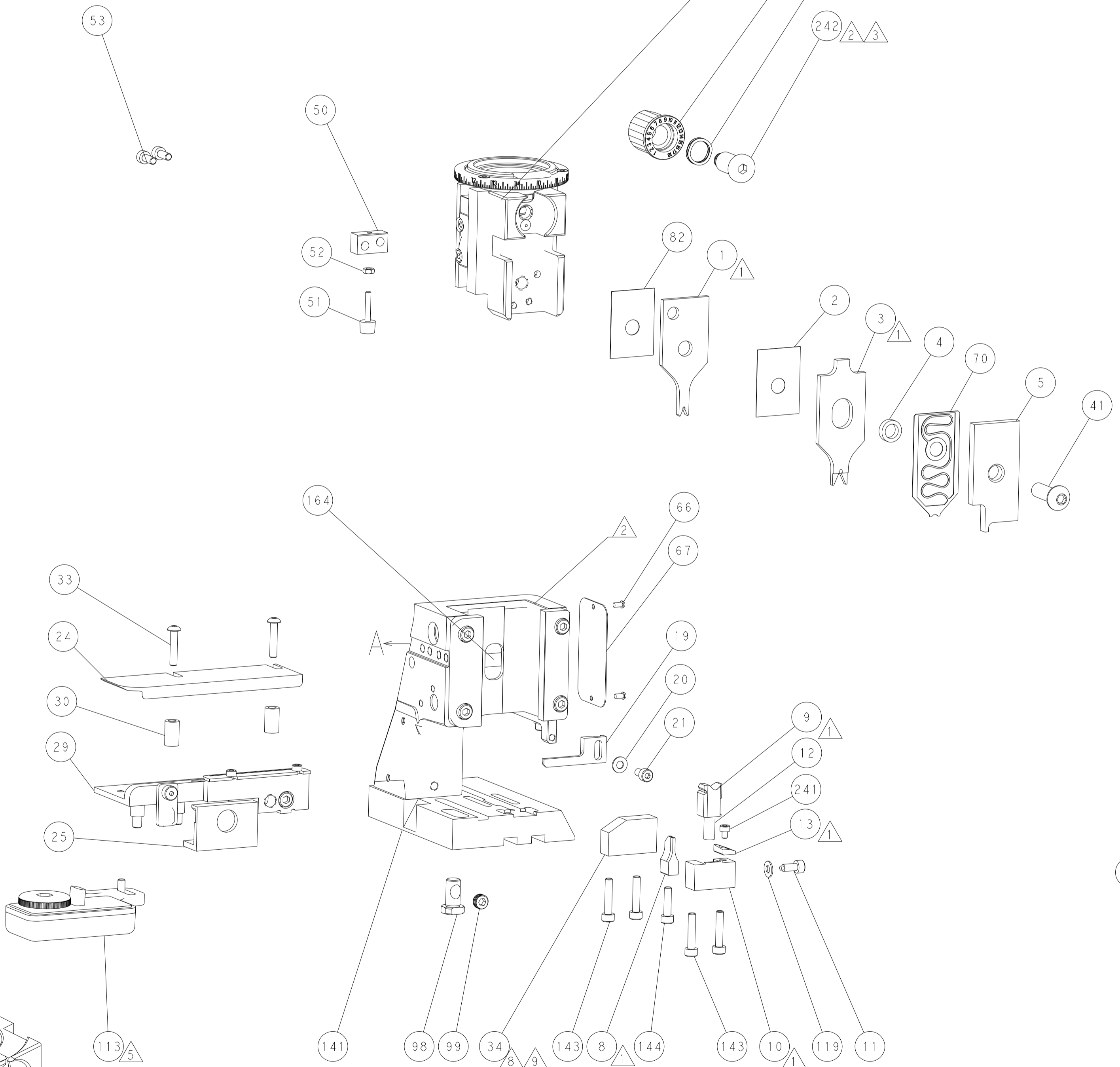
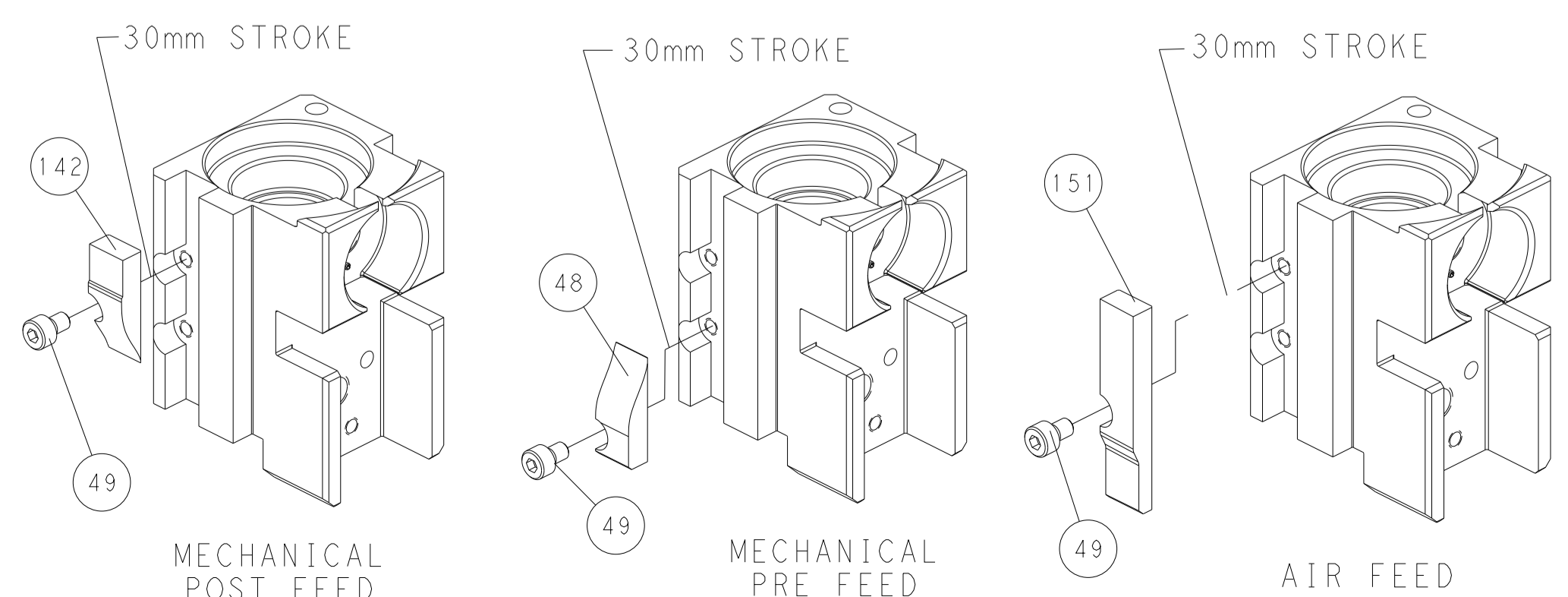

TERMINAL SUPPORT LOCATION
FOR ALL PIN TERMINALS

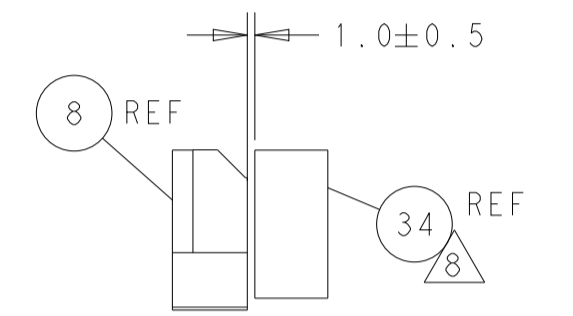

TERMINAL SUPPORT LOCATION
FOR ALL SOCKET TERMINALS

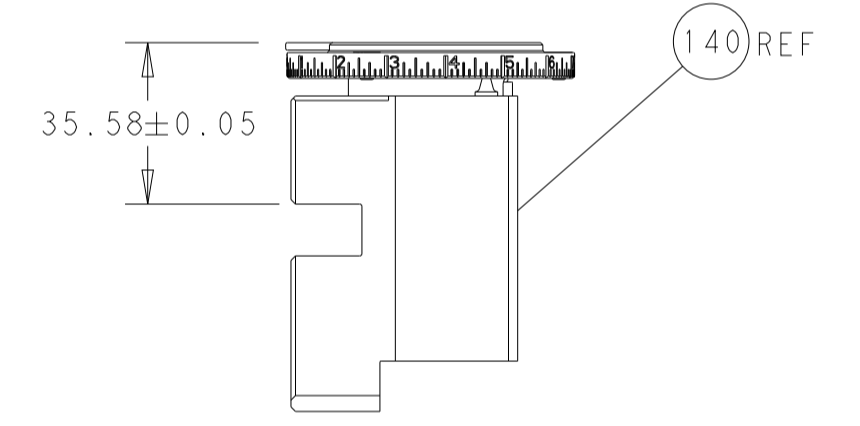

RAM SET-UP

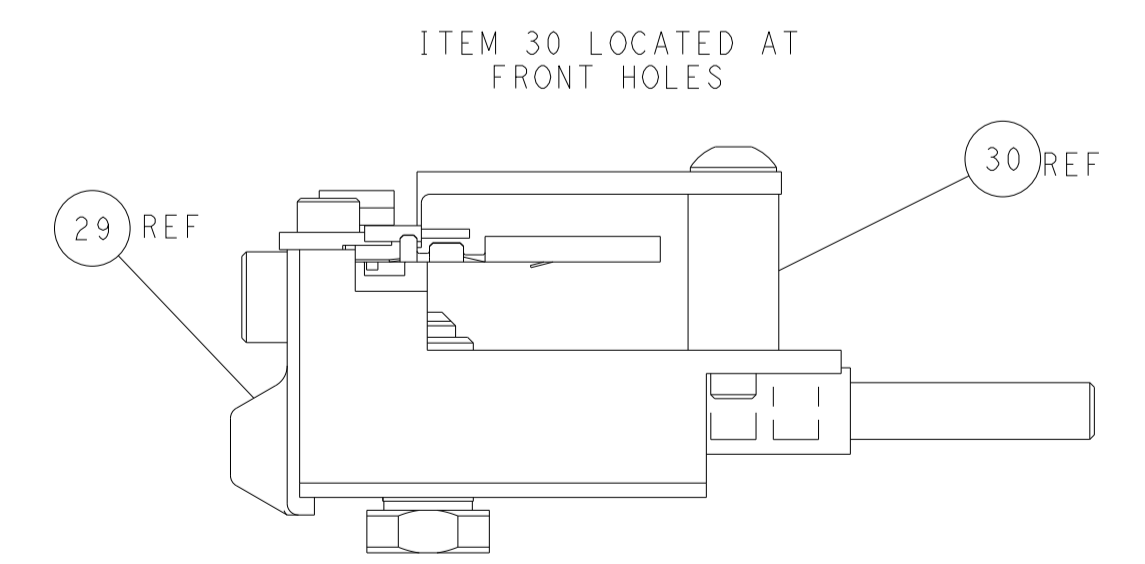

FEED TRACK POSITION
GUIDE BY INSULATION BARREL

PACIFIC VERSION
 Shown on sheets 3 of 4 & 4 of 4
 (Atlantic version shown on sheets 1 of 4 & 2 of 4)

DIMENSIONS:		TOLERANCES UNLESS OTHERWISE SPECIFIED:		MATERIAL:		FINISH:		WEIGHT:		SCALE:	
mm	0 PLC	±									
	1 PLC	±									
	2 PLC	±									
	3 PLC	±									
	4 PLC	±									
	ANGLES	±									

OWN	J. HOU	06FEB2015	NAME	Ocean Side Feed Applicator	
CHK	L. ZHANG	06FEB2015	SIZE	A1	00779
APVD	J. GUO	06FEB2015	CAGE CODE	C=2266673	
PRODUCT SPEC					
APPLICATION SPEC					
RESTRICTED TO					
Customer Accessible Production Drawing	SCALE	1:2	SHEET	4	OF 4
REV	K1				

单击下面可查看定价，库存，交付和生命周期等信息

[>>TE Connectivity\(泰科\)](#)