

THIS DRAWING IS UNPUBLISHED.



RELEASED FOR PUBLICATION

ALL RIGHTS RESERVED.

© COPYRIGHT - By -

REVISIONS

P	LTR	DESCRIPTION	DATE	DWN	APVD
	C2	REVISED PER ECO-13-019588	13DEC2013	KH	DR
	C3	REVISED PER ECO-17-008808	08FEB2018	RS	DR

 E13288 Listed	 LR7189 Certified
22-16 AWG SOLID OR STARNDDED	22-16 AWG SOLID OR STARNDDED

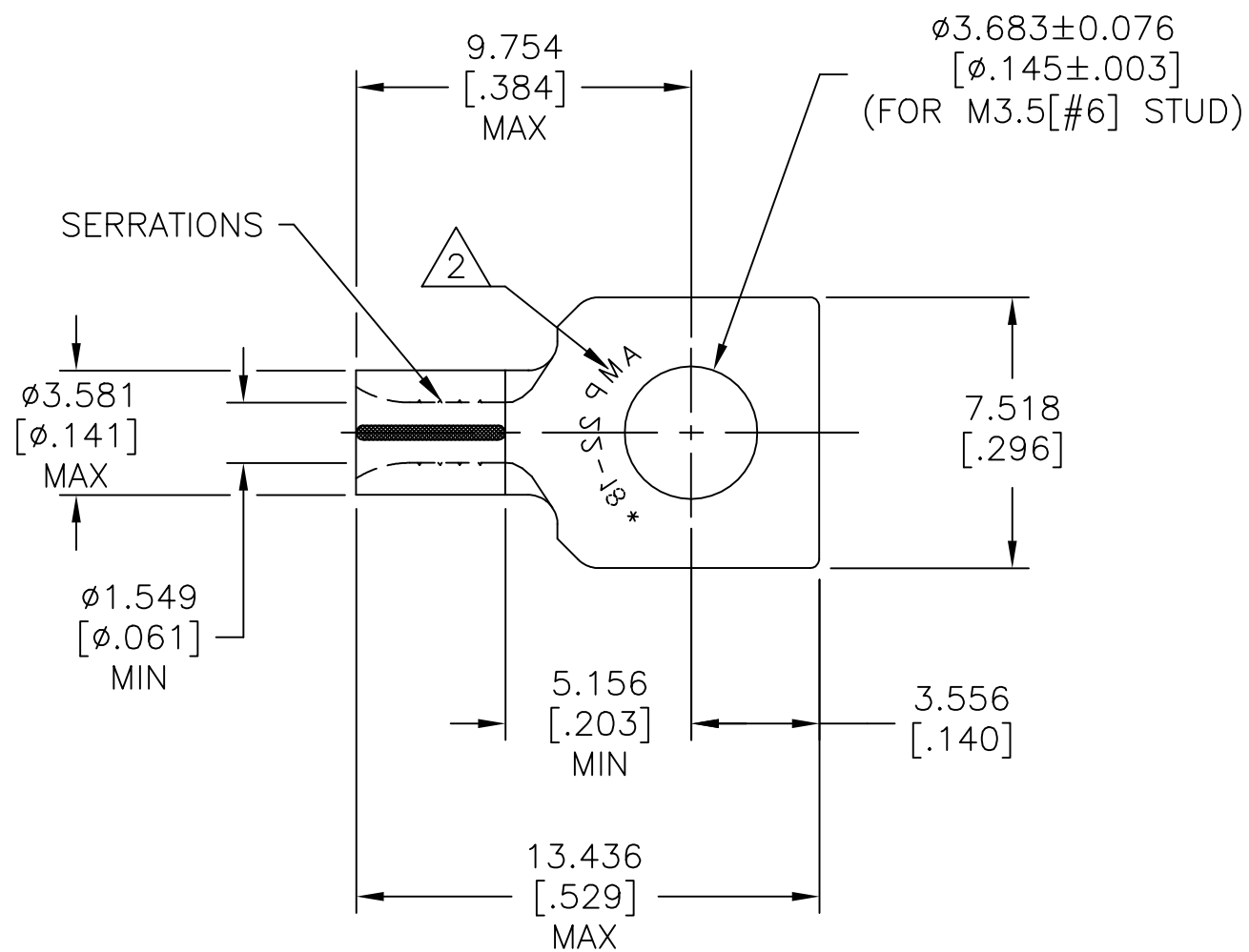

- 1 MATERIAL: COPPER 0.787±0.051 [.031±.002] THK (ASTM-B152)  
FINISH: TIN PLATE (ASTM-B545)  
ANNEALED
- 2 MARKING 22-18 FOR MILITARY  
COMMERCIAL RANGE 22-16

1000	LOOSE PIECE	34263
QTY	PACKAGE TYPE	PART NO

AMP INCORPORATED  
CUSTOMER SERVICE SYSTEMS

THIS DRAWING IS A CONTROLLED DOCUMENT.

DWN RAGHAVENDRA 03JUL09

CHK JEFF RUTH 03JUL09

APVD TOM MICHIELUTTI 03JUL09

 TE Connectivity Ltd.

FOR ADDITIONAL PRODUCT INFORMATION OR COPIES OF DRAWINGS AND TECHNICAL DOCUMENTS PRODUCT INFORMATION CENTER 1-800-522-6752

FOR APPLICATION TOOLING ASSISTANCE CENTER TOOLING INFORMATION 1-800-722-1111

FOR ORDER ENTRY 1-800-526-5142

MAX RECOMMENDED OPERATING TEMPERATURE: 170°C [338°F] MAX

VOLTAGE RATING: NOT APPLICABLE

WIRE CROSS SECTIONAL AREA RANGE, 0.26-1.65mm²[509-3,260] CIR MILS SOLID OR STRANDED

DIMENSIONS: mm [INCHES]

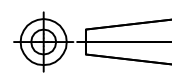

TOLERANCES UNLESS OTHERWISE SPECIFIED:

0 PLC	± -
1 PLC	± -
2 PLC	± -
3 PLC	± 0.127[.005]
4 PLC	± -
ANGLES	± .5°

MATERIAL



FINISH



NAME WIRE TERMINAL, SOLISTRAND, RECTANGULAR TONGUE WIRE SIZE: 22-16

SIZE	CAGE CODE	DRAWING NO	RESTRICTED TO
A3	00779	C=34263	-

CUSTOMER DRAWING SCALE 5:1 SHEET 1 OF 1 REV C3

单击下面可查看定价，库存，交付和生命周期等信息

[>>TE Connectivity\(泰科\)](#)