

LOC		DIST		REVISONS			
DF	FO	TR	LYR	DESCRIPTION	DATE	OWN	APPR
		C		REV PER 063D-0417-02	10-02	CT	DN

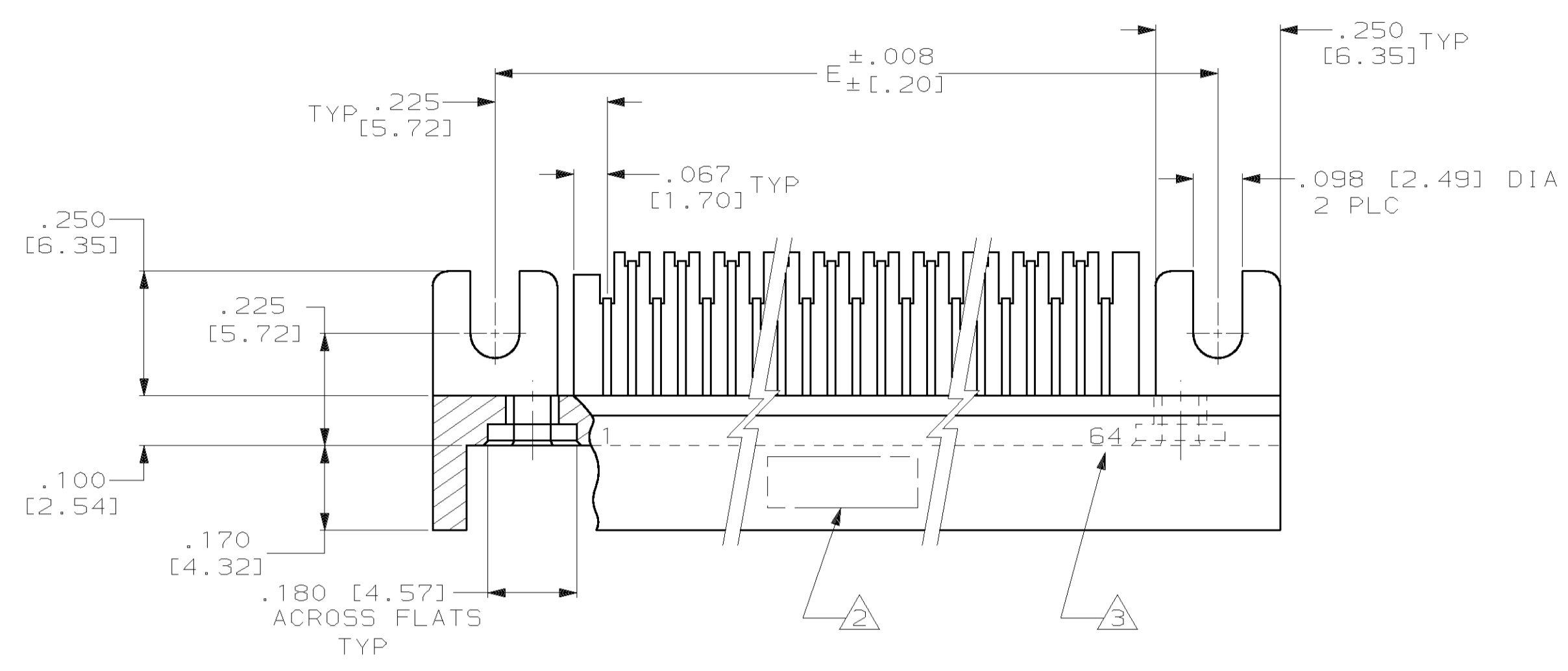

- CONNECTOR MEETS ALL APPLICABLE REQUIREMENTS OF MIL-C-55302.
- AMP, 00779, AMP PART NO, CUSTOMER PART NO. (PER TABLE) AND DATE CODE MARKED IN THIS APPROXIMATE AREA.
- END CAVITY IDENTIFICATION NUMBERS (PER TABLE) MARKED THIS SIDE ONLY.
- EPOXY, FOR CONTACT RETENTION AND SEALING, APPLIED TO CONTACT ROWS IN THIS AREA.
- FINISH: PLATED GOLD .000050 THK PER MIL-G-45204 ON MATING END FOR A LENGTH OF .100 MIN, TAILS PLATED TIN-LEAD .000120 THK, ALL OVER NICKEL .000050 THK PER QQ-N-290.
- SPACE IN TONGUE NOT APPLICABLE FOR 20 THRU 50 POSITIONS.
- PART MUST PASS SEALING EFFECTIVENESS TEST PER 109-9005.
- HOUSING MATERIAL: LIQUID CRYSTAL POLYMER PER MIL-M-24519, GLCP-30F; COLOR: GRAY.

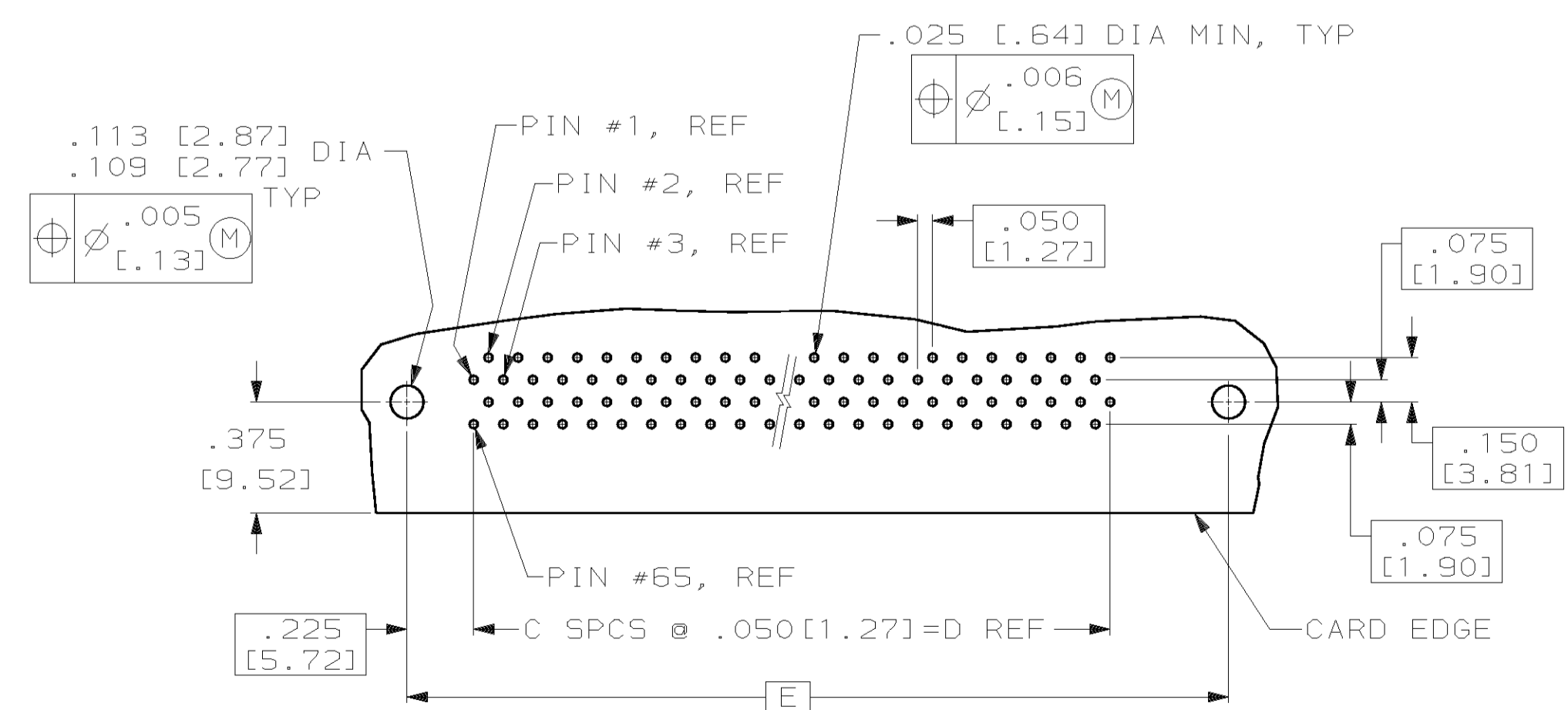
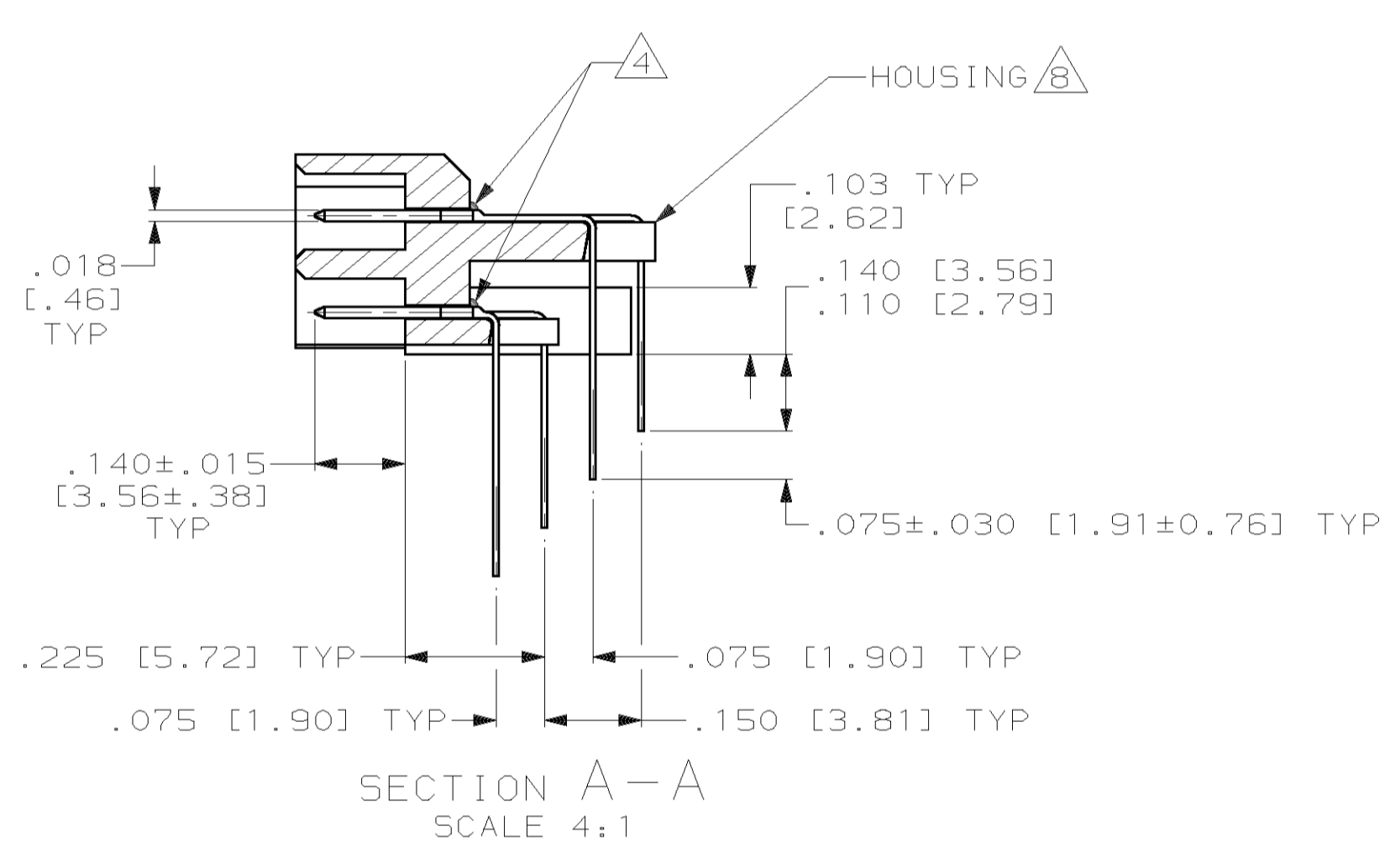
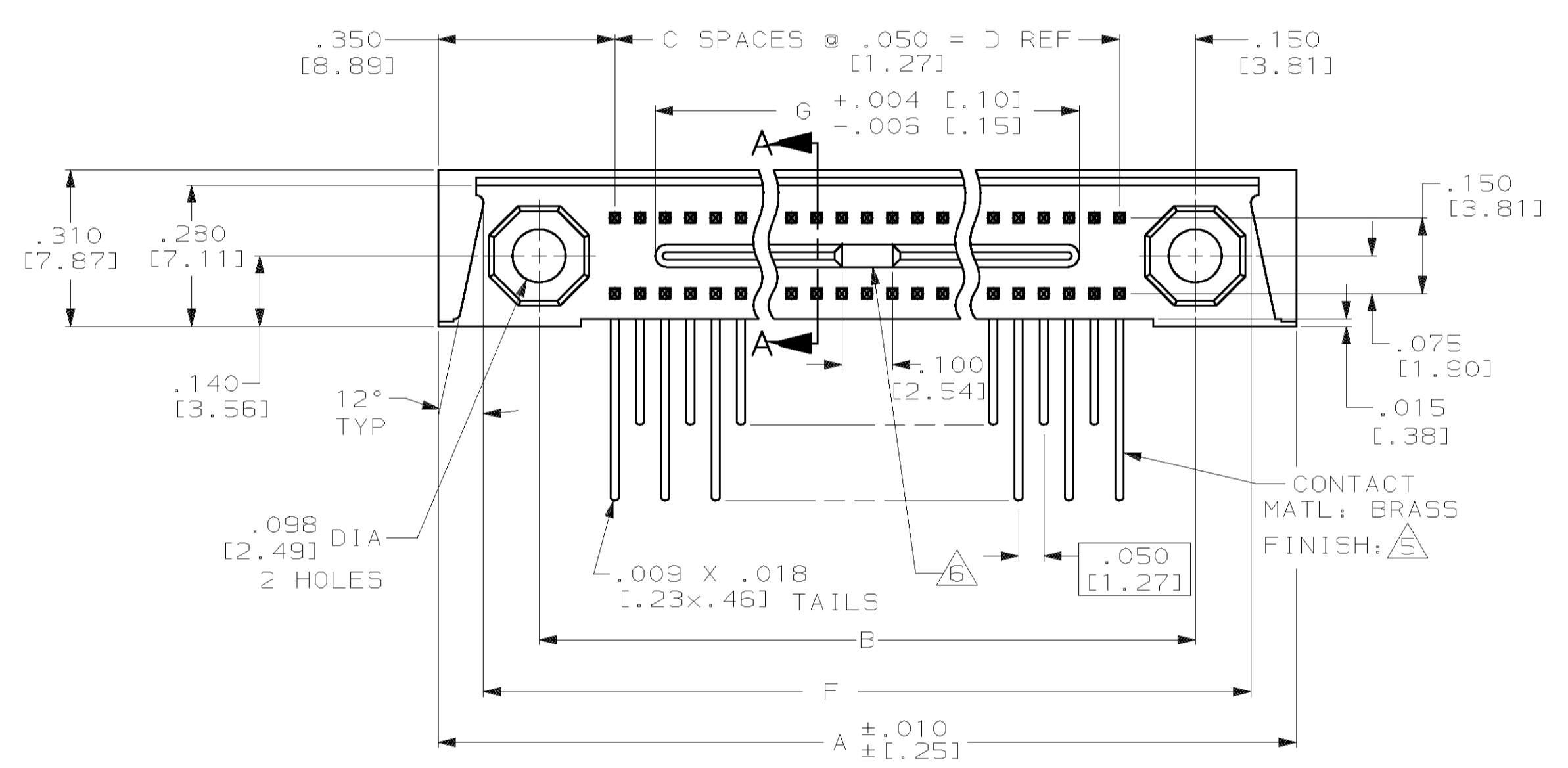

7060015-8	1 - 45	2.040 [51.82]	2.720 [69.09]	2.650 [67.31]	2.200 [55.88]	44	2.500 [63.50]	2.900 [73.66]	90	443261-4
7060015-1	1 - 10	.290 [7.37]	.970 [24.64]	.900 [22.86]	.45 [11.43]	9	.750 [19.05]	1.150 [29.21]	20	443261-3
7060015-2	1 - 15	.540 [13.72]	1.220 [30.99]	1.150 [29.21]	.700 [17.78]	14	1.000 [25.40]	1.400 [35.56]	30	443261-2
7060015-11	1 - 64	2.990 [75.95]	3.670 [93.22]	3.600 [91.44]	3.150 [80.01]	63	3.450 [87.63]	3.850 [97.79]	128	443261-1
CUSTOMER PART NUMBER	CAVITY IDENT	G	F	E	D	C	B	A	NO OF POSN	PART NUMBER

AMP Incorporated  
Harrisburg, PA 17105-3608

PIN HEADER ASSEMBLY, MINI-BOX, RIGHT ANGLE

AMP 00779 C-443261

SCALE 4:1 SHEET 1 OF 1 REV C

单击下面可查看定价，库存，交付和生命周期等信息

[>>TE Connectivity\(泰科\)](#)