

THIS DRAWING IS UNPUBLISHED. RELEASED FOR PUBLICATION
 © COPYRIGHT - By - ALL RIGHTS RESERVED.

REVISIONS					
P	LTR	DESCRIPTION	DATE	DWN	APVD
E1		REVISED PER ECO-16-004223	20JUL2016	NK	MZ
F		REVISED PER ECO-16-017885	06OCT2017	RS	MZ

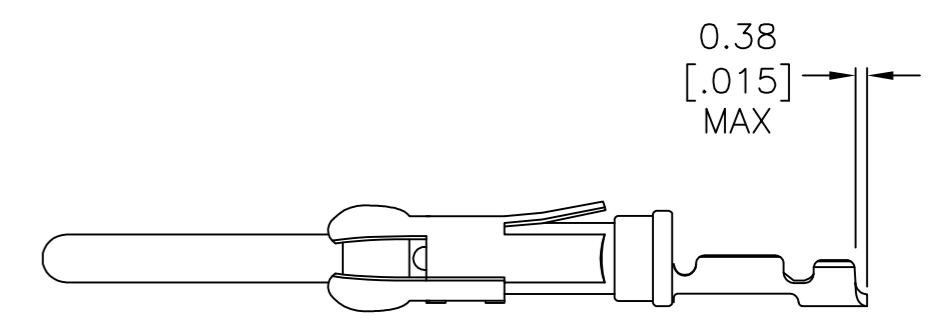

DETAIL C
 SCALE 4:1

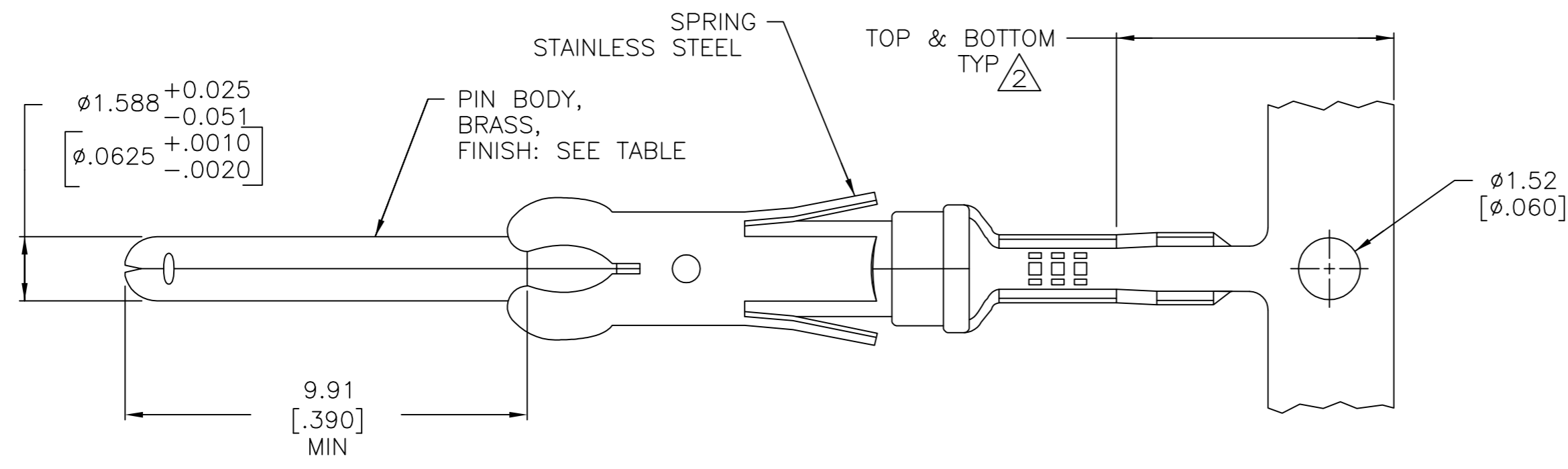
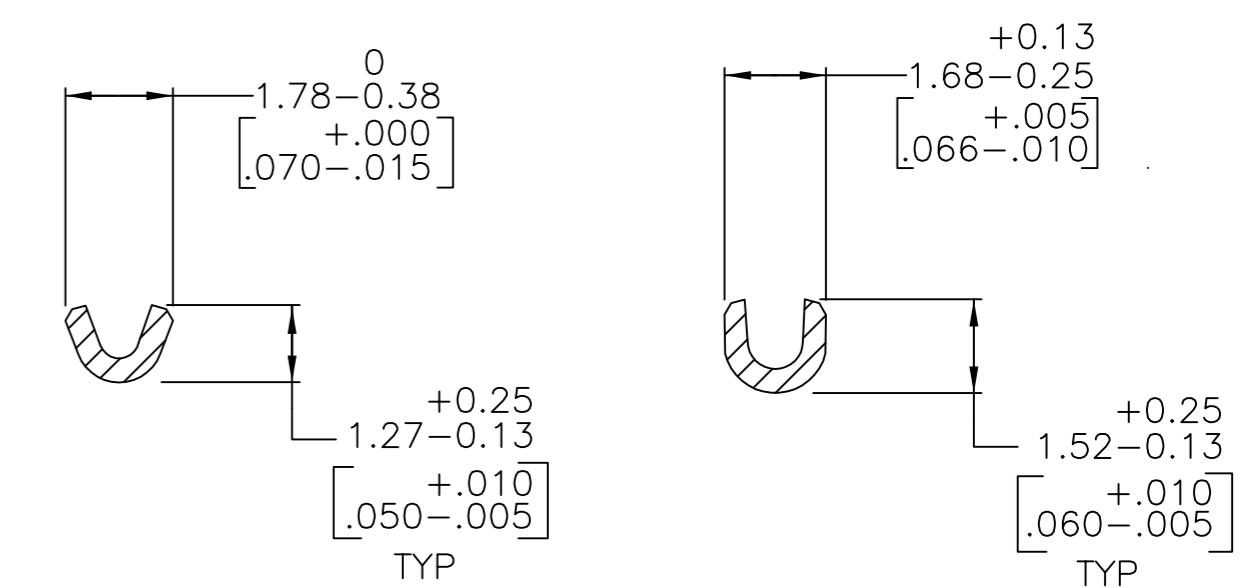
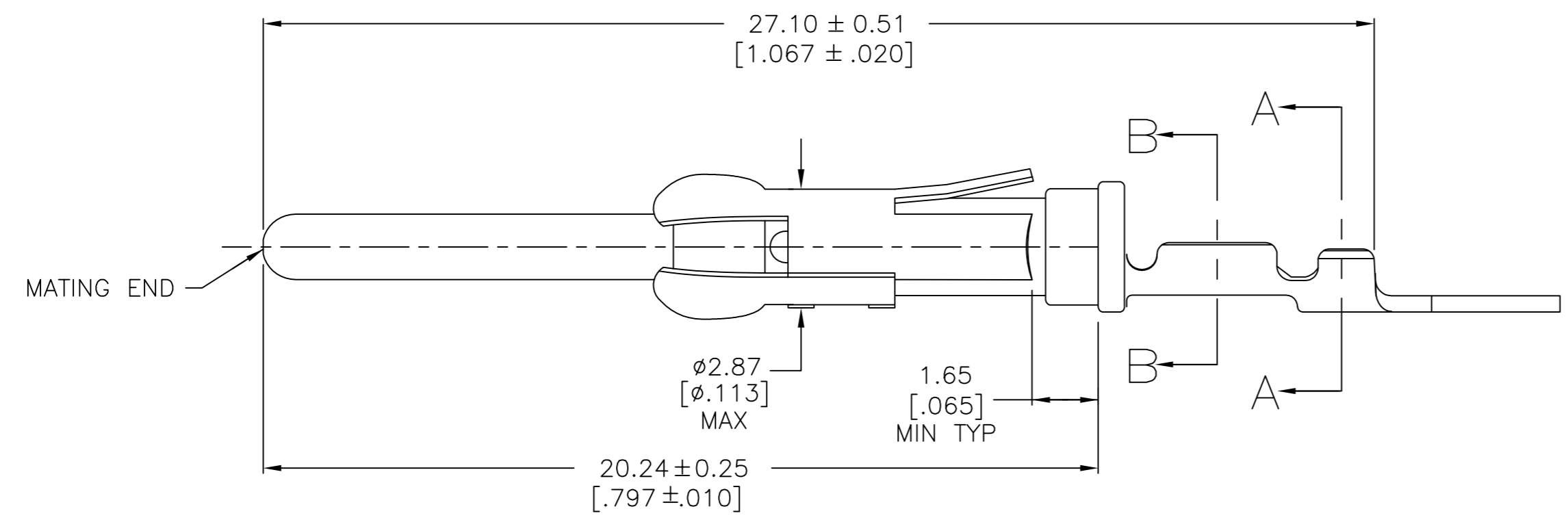

SECTION B-B SECTION A-A

- $\triangle 1$ 0.76 μ m [.000030] MIN PRECIOUS METAL PLATE ON MATING END FOR A LENGTH OF 5.08 [.200] MIN WITH 1.27 μ m [.000050] MIN MATTE TIN PLATE IN WIRE CRIMP AREA, BOTH OVER 1.27 μ m [.000050] MIN NICKEL PLATE. CONFORMS TO THE REQUIREMENTS OF TE CONNECTIVITY PRODUCT SPEC 108-10042, BASED ON EIA/ECA-364-1000.01A (CONTROLLED ENVIRONMENT APPLICATIONS).
- $\triangle 2$ GOLD PLATING NEED NOT APPEAR IN THIS AREA.
- 3 REELED FOR MINI-APPLICATOR.
- 4 WIRE RANGE 28-30 AWG. INSULATION RANGE $\phi 3.81$ [$\phi 0.15$]- $\phi 7.62$ [$\phi 0.30$].
- $\triangle 5$ 0.76 μ m [.000030] MIN PRECIOUS METAL PLATE ON MATING END FOR A LENGTH OF 5.08 [.200] MIN WITH A UNIFORM GRADIENT TO 0.25 m [.000010] ON REMAINDER, OVER 1.27 μ m [.000050] MIN NICKEL PLATE. GOLD FLASH ALL OVER. CONFORMS TO THE REQUIREMENTS OF TYCO ELECTRONICS PRODUCT SPEC 108-10042, BASED ON EIA/ECA-364-1000.01A (CONTROLLED ENVIRONMENT APPLICATIONS).
- $\triangle 6$ 0.38 μ m [.000015] MIN GOLD PER MIL-G-45204 ON MATING END FOR A LENGTH OF 5.08 [.200] MIN WITH 1.27 μ m [.000050] MIN MATTE TIN PLATE IN WIRE CRIMP AREA, BOTH OVER 1.27 μ m [.000050] MIN NICKEL PER QQ-N-290.

OBSOLETE	PER DETAIL C	$\triangle 1$	788085-4
	-	$\triangle 6$	788085-3
OBSOLETE	-	$\triangle 5$	788085-2
	-	$\triangle 1$	788085-1
LOOSE PIECE		FINISH	PART NUMBER

THIS DRAWING IS A CONTROLLED DOCUMENT.

DIMENSIONS: mm [INCHES]	TOLERANCES UNLESS OTHERWISE SPECIFIED:	DWN C. OBERMAN 21 NOV 96	TE Connectivity	
ϕ	0 PLC \pm - 1 PLC \pm - 2 PLC \pm 0.13 [.005] 3 PLC \pm - 4 PLC \pm - ANGLES \pm -	CHK R. STONE 22 NOV 96	NAME G. STEINHAUER	
MATERIAL SEE CALLOUTS	FINISH SEE CALLOUTS	APVD G. STEINHAUER 22 NOV 96	PRODUCT SPEC 108-10042	
			APPLICATION SPEC 114-10004	
		WEIGHT -	SIZE A2	CAGE CODE 00779
		CUSTOMER DRAWING	DRAWING NO C=788085	RESTRICTED TO -
			SCALE 4:1	SHEET 1 of 1
				REV F

单击下面可查看定价，库存，交付和生命周期等信息

[>>TE Connectivity\(泰科\)](#)