

8	7	6	5	4	3	2	1
THIS DRAWING IS UNPUBLISHED.		RELEASED FOR PUBLICATION		2018			
COPYRIGHT 2018 BY		ALL RIGHTS RESERVED.					
PART NUMBER	REV	DESCRIPTION					
2326072-1	B	APPLICATOR W/ SPECIALIZED TERMINATOR					
2326072-2	B	APPLICATOR W/ SPECIALIZED TERMINATOR W/ COM					
2326072-3	B	APPLICATOR ONLY					
7-2326072-7	B	CRIMP TOOLING KIT					

APPLICATOR DATA		
CRIMP	SIZE	TYPE
WIRE	2.794 mm [.110]	F
APPLICATOR INSTRUCTIONS 408-35046		

TERMINAL DATA: TE TERMINAL		TE CRIMP SPECIFICATION	
TERMINAL NAME: (AMPLIVAR) THRU SPLICE			
LEAD WIRE STRIP LENGTH		INSULATION DIAMETER RANGE	
7.09-8.66mm [.279-.341 IN]			
TERMINAL APPLICATION SPECIFICATION	114-2009		
TERMINALS APPLIED			
TE TERMINAL	TE TERMINAL	TE TERMINAL	TE TERMINAL
2238122-1	42119-1	41899	-
-	-	-	-
-	-	-	-

WIRE SIZE	CRIMP HEIGHT mm [INCH]	CRIMP HEIGHT REFERENCE SETTING
5000 CMA [MAX]	2.06±0.05mm [.081±.002 IN] REF	4.1
1500 CMA [MIN]	1.60±0.05mm [.063±.002 IN] REF	9.2

***WARNING**
ON INSTALLATION, SET WIRE DISC TO CRIMP HEIGHT REFERENCE SETTING FOR LARGEST WIRE SIZE. CRIMP HEIGHT REFERENCE SETTINGS GREATER THAN THE VALUE SHOWN MAY CAUSE DAMAGE TO THE CRIMP TOOLING, REFER TO THE INSTRUCTION SHEET FOR PROPER SETUP AND ADJUSTMENTS.

- RECOMMENDED SPARE PARTS
- REFER TO SUPPLIED INSTRUCTION SHEET FOR CLEANING, LUBRICATION & STORAGE OF APPLICATOR.
- APPLY PART NUMBER 1-23419-5 LOCTITE TO THREADS OF ITEM 248.
- CRIMP HEIGHT REFERENCE SETTING WAS THE SETTING USED WHEN THE APPLICATOR WAS QUALIFIED AT THE FACTORY. ADJUSTMENT MAY BE NECESSARY WHEN RUNNING APPLICATOR IN THE FIELD.
- 5. UNLESS OTHERWISE SPECIFIED TORQUE VALUES SHALL BE USED PER DOCUMENT 101-35000
- ITEM NOT SHOWN
- GREASE BEARING SURFACES LIGHTLY.
- GREASE THREADS AND GROOVE OF ITEM 35 AND O-RING, ITEM 252.
- APPLY GREASE FILLING IN VOIDS/CAVITIES OF DETENT PLATE, ITEM 249.
- MAGNET, ITEM 166, MUST BE ORIENTED CORRECTLY IN ORDER TO PROPERLY ACTUATE THE COUNTER.
- REFER TO TERMINAL CUSTOMER DRAWING FOR CRIMP HEIGHT FORMULA TO CALCULATE SPECIFIC CRIMP HEIGHTS.
- INCLUDE A COPY OF THIS APPLICATOR LOG SHEET WITH THE DOCUMENTATION PACKAGE, ITEM 71.
- TERMINAL LUBRICANT IS RECOMMENDED.

	-	2	2	2	-	5018030-2	NUT, HEX, REG, RoHS, M4	270
	-	2	2	2	-	1-18028-2	WASHER, FLAT, REG M4	269
	-	2	2	2	-	2-2168083-6	SCR, SKT HD CAP, RoHS M4 X 18.0	268
	-	2	2	2	-	992342-2	SCREW, ASSEMBLY, THUMB	267
	-	1	1	1	-	2373745-1	BRACKET	266
	-	1	1	1	-	2119955-2	ASSY, LUBRICATOR	265
	-	-	2	2	-	23238-1	INSERT, COUPLING	264
	-	REF	1	-	-	2326540-4	TERMINATOR, 5K CE W/ CQM, MODIFIED, THROUGH SPLICE	263
	-	-	457	457	-	2030758-3	TUBING, POLYURETHANE	262
	-	REF	-	-	-	2325998-1	GUARD INSERT, THROUGH SPLICE	261
	-	REF	-	1	-	2326540-2	TERMINATOR, 5K CE, MODIFIED, THROUGH SPLICE	260
	-	1	1	1	-	8-21084-0	O-RING, .676 ID, .070 DIA. MAT.	252
	-	3	3	3	-	1-1655784-6	SCR, FLT SKT HD CAP, M3 X 6	250
	-	1	1	1	-	2844969-1	DETENT PLATE	249
	-	1	1	1	-	7-1655316-0	SCR, SKT HD CAP, M8 X 25.0	248
	-77	-3	-2	-1	U/M	PART NO	DESCRIPTION	ITEM NO

	-	1	1	1	-	2844970-1	DETENT PIN	247
	-	1	1	1	-	2-22279-6	SPRING, COMPRESSION	246
	-	2	2	2	-	21045-3	RING, RETAIN, EXTERN, 3/16 CRESCENT	172
	-	1	1	1	-	994969-1	MAGNET, RARE EARTH, HIGH ENERGY	166
	-	REF	REF	REF	-	994970-2	COUNTER, MAGNETIC	164
	-	1	1	1	-	240638-1	SPRING, FEED FINGER	163
	-	1	1	1	-	2305752-1	FEED ARM	142
	-	1	1	1	-	3-23627-7	PIN, RETAIN, GRVD, 3/16 X .854	137
	-	1	1	1	-	2280548-1	HOLDER, FEED FINGER	136
	-	4	4	4	-	2079160-3	SPRING PLUNGER, M4	115
	-	4	4	4	-	2079844-1	SPRING PLUNGER, M4	110
	-	1	1	1	-	2217397-1	WHEEL, ADJUST	109
	-	2	2	2	-	992976-7	VALVE, SPEED CONTROLLER	108
	-	1	1	1	-	2119454-1	KNOB, FEED ADJUST	106
	-	1	1	1	-	2280501-1	GUIDE, FEED ARM	105
	-	1	1	1	-	2256823-2	CYLINDER, AIR, DOUBLE ACTING, COMPACT	103
	-	2	2	2	-	2280416-1	ROD END, CYLINDER	102
	-	8	8	8	-	2-18023-3	SCR, SKT HD CAP M5 X 30.0	101
	-	1	1	1	-	992946-2	PIN, DOWEL 3 X 16	100
	-	1	1	1	-	3-18031-7	SCR, SET, CUP POINT M6 X 4.0	99
	-	1	1	1	-	2-22279-9	SPRING, COMPRESSION	98
	-	1	1	1	-	2280506-2	LEVER, TERMINAL SUPPORT	97
	-	1	1	1	-	5-1655316-4	SCR, SKT HD CAP, M5 X 12.0	96
	-	5	5	5	-	2-2168083-0	SCR, SKT HD CAP, RoHS, M5 X 12	95
	-	1	1	1	-	2305749-1	MOUNT, TERMINAL SUPPORT LEVER	94
	-	1	1	1	-	2305715-2	GUIDE, TERMINAL TRANSFER	85
	-	1	1	1	-	2305714-2	GUIDE, TERMINAL TRANSFER	84
	-	1	1	1	-	6-1655316-0	SCR, SKT HD CAP, M5 X 40.0	82
	-	1	1	1	-	1-22281-8	SPRING, COMPRESSION	81
	-	1	1	1	-	2326541-1	DOCUMENTATION PACKAGE	71
	-	1	1	1	-	2119740-1	TAG, IDENTIFICATION	67
	-	2	2	2	-	2168078-1	SCREW, DRIVE, RH, RoHS, 2 x .188	66
	-	1	1	1	-	5-18022-5	SCR, HEX HD CAP, M4 X 6.0	59
	-	1	1	1	-	2280106-1	FINGER, FEED	56
	-	1	1	1	-	1-18028-2	WASHER, FLAT, REG M4	55
	-	8	8	8	-	2168400-4	SHCS, LOW HEAD, RoHS, M4 X 8	54
	-	1	1	1	-	2280396-1	RETAINER, UPPER TOOLING	52
	-	2	2	2	-	5-22280-5	SPRING, COMPRESSION	50
	-	1	1	1	-	4-2119656-0	APPLICATOR BASIC ASSEMBLY, SF	46
	-	1	1	1	-	2326441-1	RAM, ATLANTIC STYLE, INVERTED SPLICE	44
	-	3	3	3	-	2168083-2	SCR, SKT HD CAP, RoHS, M4 X 8.0	41
	-	1	1	1	-	2844968-1	DISC, NUMBERED FA WIRE ADJUSTMENT	40
	-	2	2	2	-	1-18032-2	SCR, SET, FLT PNT, M8 X 8.0	39
	-	2	2	2	-	1655316-9	SCR, SKT HD CAP, M2.5 X 12.0	38
	-	1	1	1	-	2844967-1	FA HEAD, ATLANTIC STYLE	37
	-	1	1	1	-	2844971-1	BOLT, ADJUSTMENT	35
	-	2	2	2	-	2280415-1	MOUNT, CYLINDER	32
	-	1	1	1	-	2305748-1	MOUNT, STRIP GUIDE	30
	-	2	2	2	-	18032-7	SCR, SET, FLT PNT, M5 X 12.0	29
	-	2	2	2	-	2-18032-5	SCR, SET, FLT PNT, M5 X 20.0	28
	-	2	2	2	-	22283-1	SPRING, COMPRESSION	27
	-	1	1	1	-	2280503-1	LEVER, DRAG RELEASE	26
	-	1	1	1	-	2280502-9	DRAG, TERMINAL	25
	-	1	1	1	-	2305713-1	STRIP GUIDE, TERMINAL	24
	-	1	1	1	-	980371-4	SCR, SKT HD SHLDR 5.0 DIA X 6.0	23
	-	1	1	1	-	2326074-1	SHEAR BLADE	9
	1	1	1	1	-	2373761-1	DRIVE BAR	8
	1	1	1	1	-	2326076-7	CRIMPER	1
	-77	-3	-2	-1	U/M	PART NO	DESCRIPTION	ITEM NO

THIS DRAWING IS A CONTROLLED DOCUMENT.

OWN: B. WEAVER 23JUL2018
 CHG: T. BACKENSTOES 23JUL2018
 APVD: T. BACKENSTOES 23JUL2018

TE Connectivity

OCEAN INVERTED THROUGH SPLICE APPLICATOR

SIZE: A1 CAGE CODE: 00779 DRAWING NO: 2326072 RESTRICTED TO: -
 SCALE: 3:4 SHEET: 1 OF 2 REV: B

CUSTOMER ACCESSIBLE PRODUCTION DRAWING

REVISIONS				
P	LY#	DESCRIPTION	DATE	OWN
-	-	SEE SHEET 1	-	-

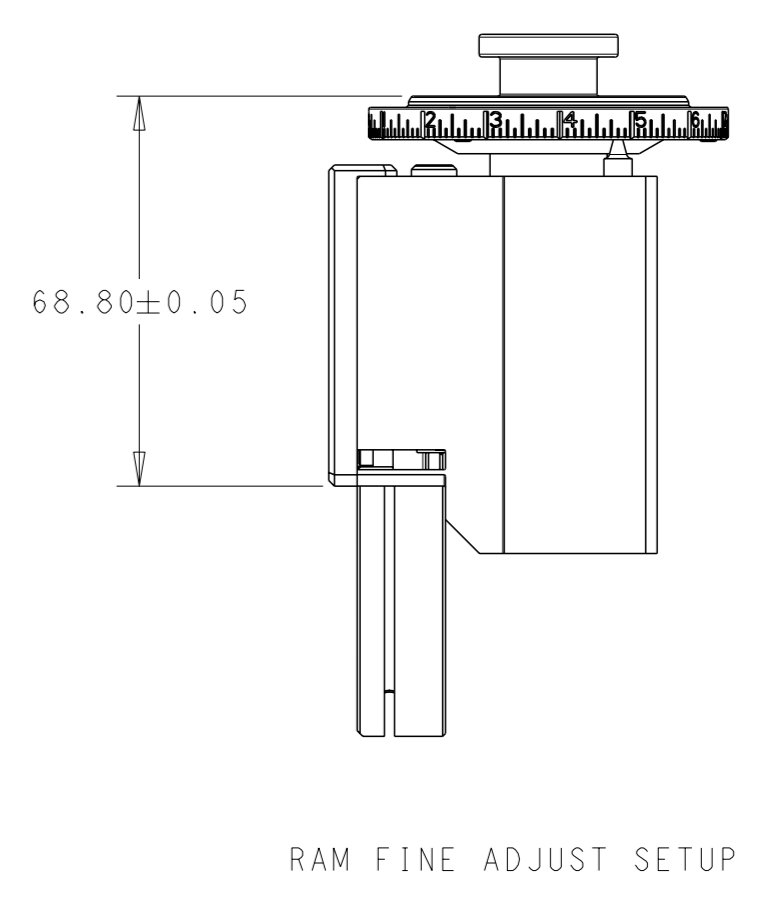
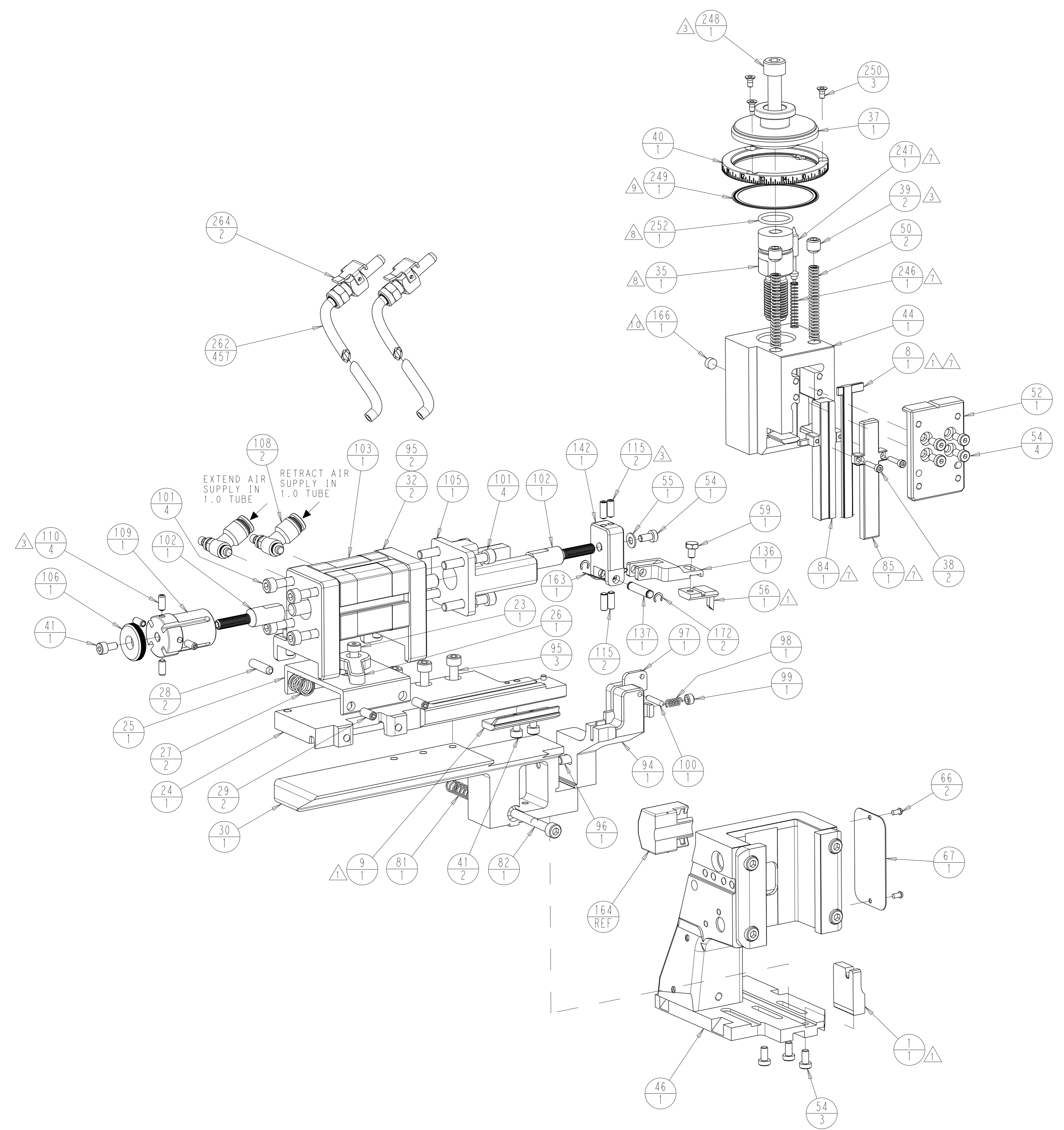

THIS DRAWING IS A CONTROLLED DOCUMENT.		OWN B. WEAVER 23 JUL 2018	TE Connectivity	
DIMENSIONS:		CHK T. BACKENSTOES 23 JUL 2018	NAME OCEAN INVERTED THROUGH SPLICE APPLICATOR	
mm		APVD T. BACKENSTOES 23 JUL 2018	PRODUCT SPEC	
		APPLICATION SPEC		
MATERIAL		SIZE	CAGE CODE	DRAWING NO.
		WEIGHT	A100779	C=2326072
		CUSTOMER ACCESSIBLE PRODUCTION DRAWING		SCALE 3:4 SHEET 2 OF 2 REV B

单击下面可查看定价，库存，交付和生命周期等信息

[>>TE Connectivity\(泰科\)](#)