

4

3

2

1

REVISIONS			
LTR	DESCRIPTION	DATE	APPROVED
A	REVISED PER ECN# T-6209	3/24/86	J.B.
B	REDRAWN PER DCR# C040637	April/29/04	M.HIGGY

If this document is printed it becomes uncontrolled.
Check for the latest revision.

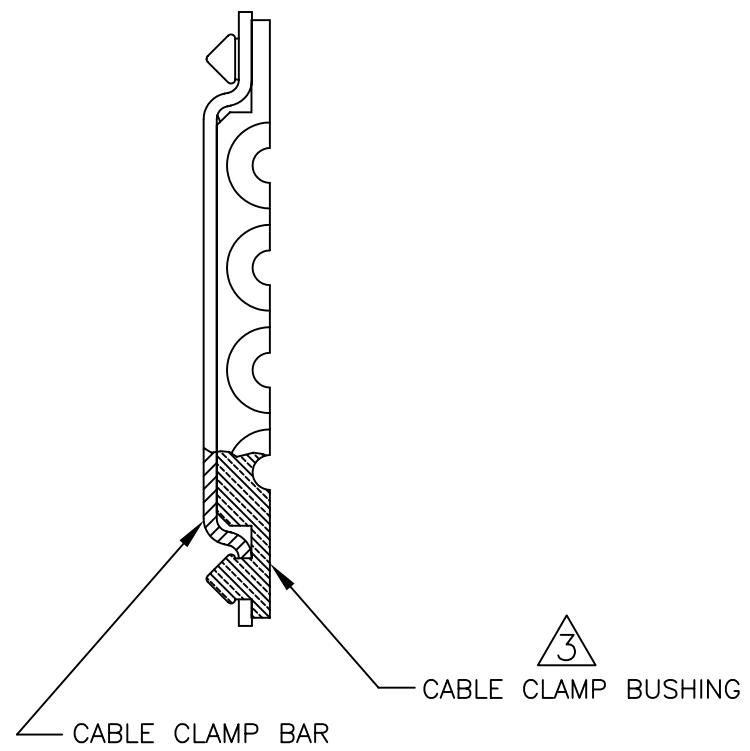
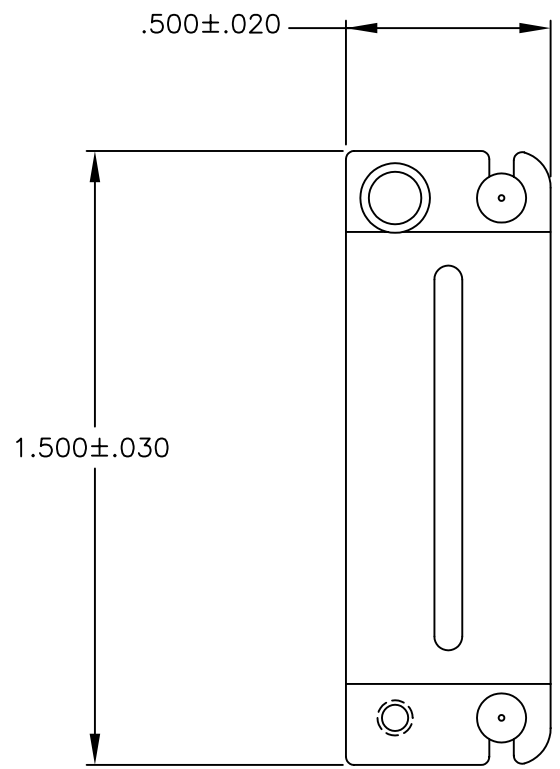

NOTES:

1. CABLE CLAMP SUB-ASSY. USED ON CONNECTOR NUMBERS:
 - a) MTCC1R-COAX01P-01
 - b) MTCC1R-COAX01S-01
 - c) MTCC1P-COAX01S-01
 - d) MTCC1P-COAX01P-01
 - e) D-659-003-03-003

2. TWO (2) CABLE CLAMP SUB-ASSEMBLIES REQUIRED FOR EACH CONNECTORS.

3 CABLE CLAMP BUSHING SUPPLIED ATTACHED TO CABLE CLAMP BAR AS SHOWN.

4. MATERIAL:
 - a) CABLE CLAMP BAR STAINLESS STEEL PER ASTM A 240
 - b) RUBBER, SILICONE A-A-59588

4. PLATING: CLAMP BAR CADMIUM PLATED PER SAE-AMS-QQ-P-416, OVER NICKEL UNDERPLATE.

SPECIFICATION CONTROL DRAWING

© 2004 Tyco Electronics Corporation. All rights reserved

UNLESS OTHERWISE SPECIFIED DIMENSIONS ARE IN INCHES. METRIC DIMENSIONS ARE IN BRACKETS. DECIMALS .XXX ±.XXX [mm] .XX ±.XX [mm] ANGLE ± X'	DRAWN ZS.ORBAN	DATE April/20/04		TYCO ELECTRONICS 300 Constitution Drive Menlo Park, CA. 94025 USA		
	CHECKED	DATE				
	APPROVED M.HIGGY	DATE April/20/04	TITLE KIT, 1 INCH CABLE CLAMP CADMIUM PLATED MTCR SERIES			
	CAD NAME C040637.DWG	SIZE C CAGE CODE: 06090 DWG. NO. D-659-0033-03-003 REV B DO NOT SCALE THIS DRAWING SCALE NONE SHEET 1 OF 1				
WEIGHT .009 lbs.max. [4.02grms max.]	THIRD ANGLE PROJECTION					

DRAWING NO. D-659-0033-03-003 SHEET 1

4

2

1

单击下面可查看定价，库存，交付和生命周期等信息

[>>TE Connectivity\(泰科\)](#)