

THIS DRAWING IS UNPUBLISHED. RELEASED FOR PUBLICATION ,19 .
 © COPYRIGHT 19 BY AMP INCORPORATED. ALL RIGHTS RESERVED.

LOC	DIST	REVISIONS					
		P	LTR	DESCRIPTION	DATE	DWN	APVD
G	14		F	REDRAWN PER 0720-0470-95	23JAN95	LO	ME

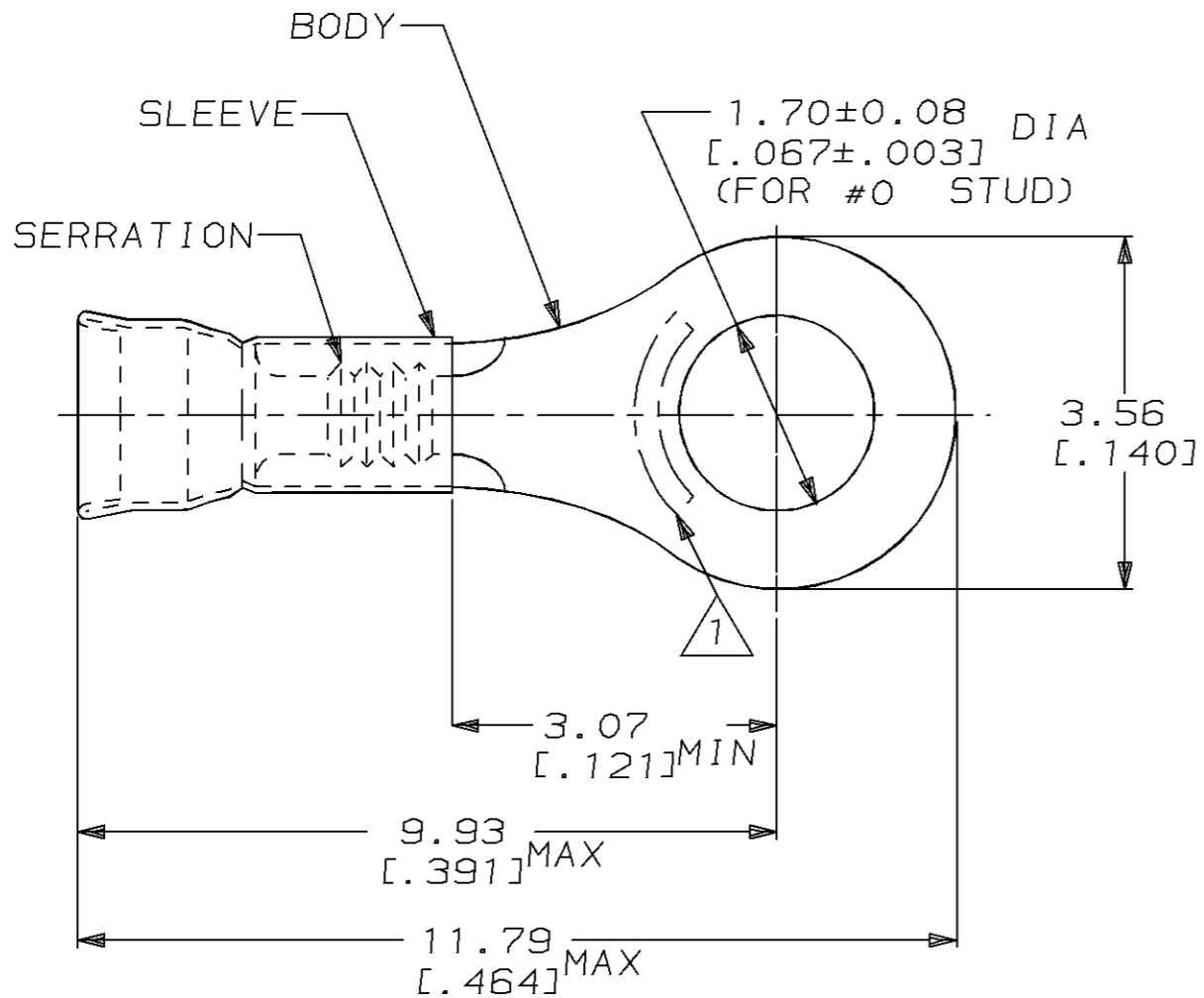

△ STAMP AMP LOCATE APPROX AS SHOWN

- WIRE INSUL DIA, 1.27-2.08 [$.050-.082$]
- TONGUE MATL THK, 0.46±0.05 [$.018 \pm .002$]

1000	LOOSE PIECE	31516
QTY	PACKAGE TYPE	PART NO

AMP INCORPORATED CUSTOMER SERVICE SYSTEM		MAX RECOMMENDED OPERATING TEMPERATURE: -	THIS DRAWING IS A CONTROLLED DOCUMENT FOR AMP INCORPORATED. IT IS SUBJECT TO CHANGE AND THE CONTROLLING ENGINEERING ORGANIZATION SHOULD BE CONTACTED FOR THE LATEST REVISION.		DWN L OLMEDA 23JAN95	AMP Incorporated Harrisburg, PA 17105-3608 NAME TERMINAL, RING, DIAMOND GRIP, WIRE SIZE, 26-22 AWG SIZE A3 CAGE CODE 00779 DRAWING NO C-31516	
FOR ADDITIONAL PRODUCT INFORMATION OR COPIES OF DRAWINGS AND TECHNICAL DOCUMENTS	PRODUCT INFORMATION CENTER 1-800-522-6752	VOLTAGE RATING: -	DIMENSIONS: mm [in]	TOLERANCES UNLESS OTHERWISE SPECIFIED:	CHK M ELLIS 23JAN95		
FOR APPLICATION TOOLING INFORMATION	TOOLING ASSISTANCE CENTER 1-800-722-1111	CIRCULAR MIL AREA: 0.10mm ² -0.41mm ² [202-810]		0 PLC ±- 1 PLC ±- 2 PLC ±0.20 [.008] 3 PLC ±- 4 PLC ±- ANGLES ±-	APVD S BORTNER 23JAN95		
FOR ORDER ENTRY	1-800-526-5142	STRANDED WIRE	MATERIAL BODY, CU, SLV, CU PER ASTM B152	FINISH TIN PLATE PER MIL-T-10727	PRODUCT SPEC - APPLICATION SPEC - WEIGHT -		
			CUSTOMER DRAWING		SCALE 10:1	SHEET 1 OF 1	REV F

单击下面可查看定价，库存，交付和生命周期等信息

[>>TE Connectivity\(泰科\)](#)