

4

3

2

1

THIS DRAWING IS UNPUBLISHED.

RELEASED FOR PUBLICATION

ALL RIGHTS RESERVED.

© COPYRIGHT - By -

REVISIONS

P	LTR	DESCRIPTION	DATE	DWN	APVD
F3		REVISED PER ECO-15-016493	26NOV2015	NK	DR
F4		REVISED PER ECO-17-016703	30MAR2018	RS	DR

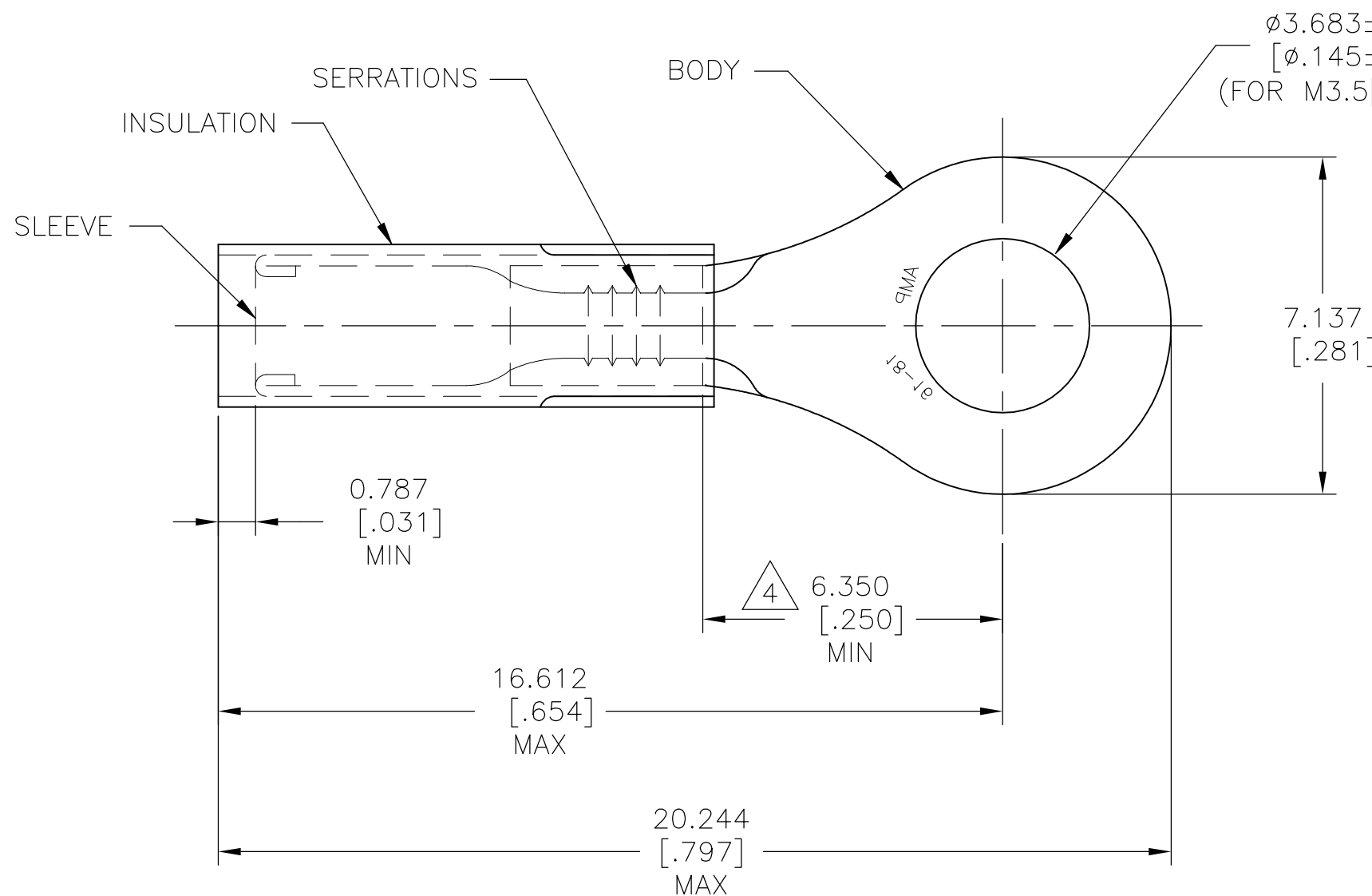

- 1 BODY: COPPER ASTM B152
NICKEL PL SAE AMS QQ-N-290
0.0076[.0003] AVG. EXT. THK
SLEEVE: COPPER ASTM B152
NICKEL PL SAE AMS QQ-N-290
0.00076[.00003] AVG EXT. THK
- 2 FOR 1.397[.055] TO 3.429[.135]
WIRE INSULATION DIA.
- 3 BODY MATERIAL THK: 0.787±0.051[.031±.002]
- 4 DIMENSION APPLIES FROM EDGE OF METAL
WIRE BARREL TO CENTER OF STUD HOLE

1000	LOOSE PIECE	50835	PTFE (ASTM D3295) COLOR: ORANGE
QTY	PACKAGE TYPE	PART NO.	INSULATION MATERIAL

AMP INCORPORATED
CUSTOMER SERVICE SYSTEMS

MAX RECOMMENDED OPERATING
TEMPERATURE:

288°C [550°F]

VOLTAGE RATING:

300V MAX

CIRCULAR MIL AREA:

0.81-1.42mm²[1,600-2,800]
STRANDED WIRE ONLY

THIS DRAWING IS A CONTROLLED DOCUMENT.

DIMENSIONS:
mm [INCHES]

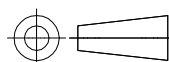

MATERIAL
1
SEE TABLE

TOLERANCES UNLESS
OTHERWISE SPECIFIED:

0 PLC	± -
1 PLC	± -
2 PLC	± -
3 PLC	± 0.127[.005]
4 PLC	± -
ANGLES	± 5°

FINISH
1
SEE TABLE

DWN 13OCT2015
NAGALAKSHMI K

CHK 13OCT2015
MERCURIO MAURIZIO

APVD 13OCT2015
MERCURIO MAURIZIO

PRODUCT SPEC

APPLICATION SPEC

WEIGHT

CUSTOMER DRAWING



TE Connectivity Ltd.

NAME
WIRE TERMINAL
PIDG™, STRATO-THERM, RING TONGUE
WIRE SIZE:18-16 AWG

SIZE	CAGE CODE	DRAWING NO	RESTRICTED TO
A3	00779	C-50835	-

SCALE NTS SHEET 1 OF 1 REV F4

单击下面可查看定价，库存，交付和生命周期等信息

[>>TE Connectivity\(泰科\)](#)