

THIS DRAWING IS UNPUBLISHED. RELEASED FOR PUBLICATION
 (C) COPYRIGHT 19 BY AMP INCORPORATED. ALL RIGHTS RESERVED.

LOC		DIST		REVISIONS			
P	LTR	DESCRIPTION	DATE	DWN	APVD		
0		RELEASED	4-00	CT	RG		
A		EC 063D-0267-01 JM	1-02	DBK	JM		

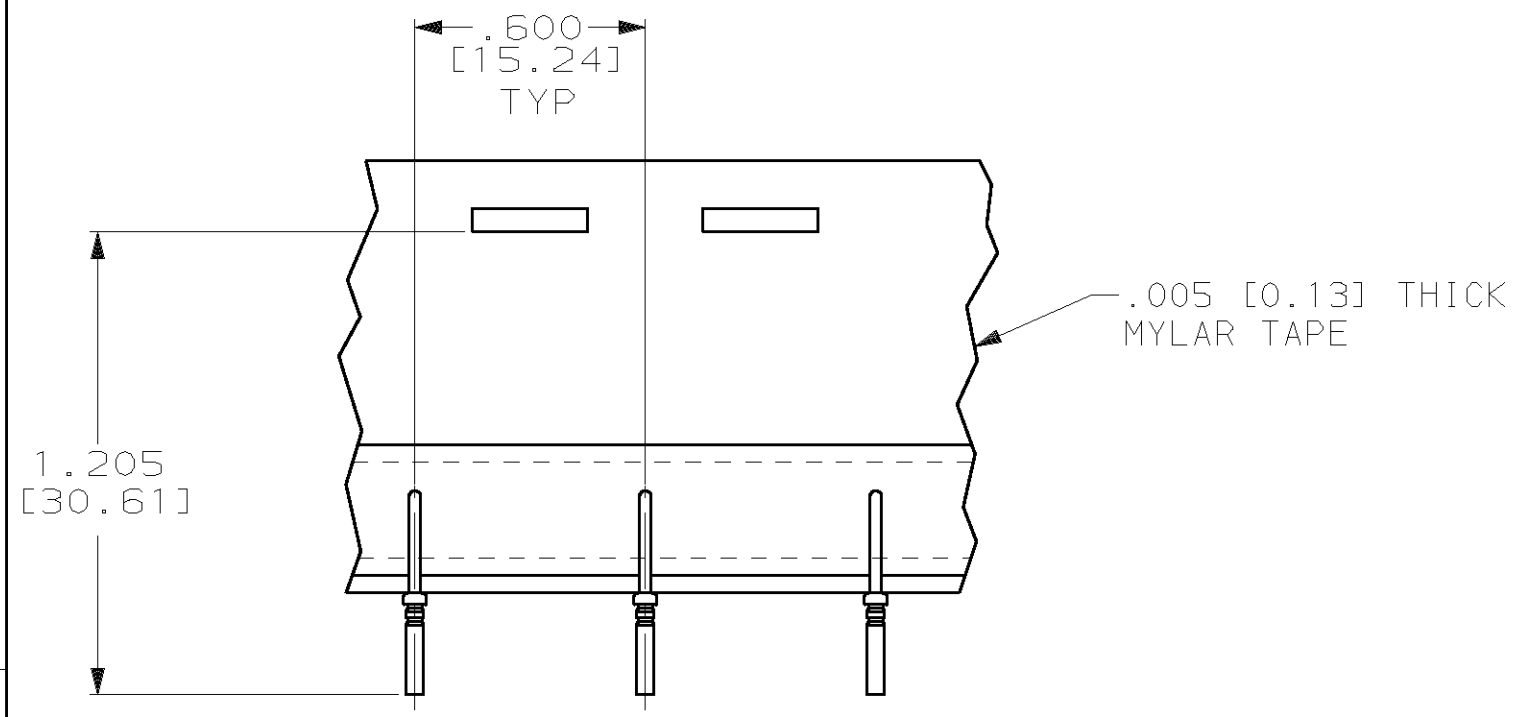

TAPE MOUNTED
 1218699-2 ONLY
 SCALE 2:1

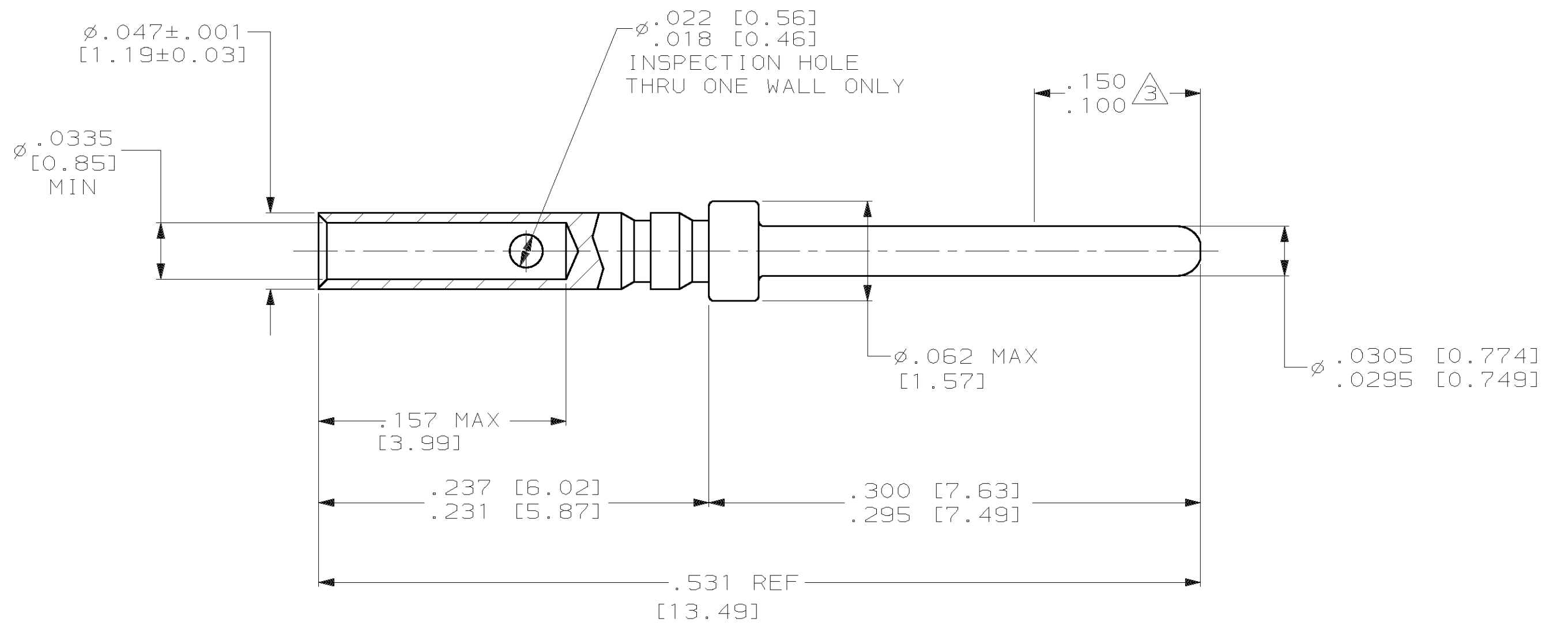

- MATERIAL: BRASS PER ASTM-C34500.
- FINISH: GOLD PLATED .000050 [0.00127] MIN THICK OVER NICKEL PLATE .000050 [0.00127] MIN THICK.
- POINT OF PLATING THICKNESS MEASUREMENT.
- WIRE BARREL WILL ACCEPT #22-28 AWG WIRE.
- CRIMPING TOOL: USE M53198-1 WITH APPLICABLE POSITIONER.
- INSERTION/EXTRACTION TOLL: AMP PART NO. 91067-1.
- FINISH: GOLD PLATED .000030 MIN THK OVER NICKEL UNDERPLATE .000050 MIN THK

FINISH	DESCRIPTION	PART NUMBER
?	LOOSE PIECE	1218699-3
2	ON TAPE	1218699-2
2	LOOSE PIECE	1218699-1

THIS DRAWING IS A CONTROLLED DOCUMENT.		DWN C.C. THOMAS 4/17/00	AMP Incorporated Harrisburg, PA 17105-3608												
DIMENSIONS: INCHES [mm]		CHK R. GROSS 4/17/00	NAME												
TOLERANCES UNLESS OTHERWISE SPECIFIED:		APVD R. GROSS 4/17/00	PRODUCT SPEC												
<table border="0"> <tr><td>0 PLC</td><td>±</td></tr> <tr><td>1 PLC</td><td>±</td></tr> <tr><td>2 PLC</td><td>±</td></tr> <tr><td>3 PLC</td><td>±.005 [0.13]</td></tr> <tr><td>4 PLC</td><td>±</td></tr> <tr><td>ANGLES</td><td>±</td></tr> </table>		0 PLC	±	1 PLC	±	2 PLC	±	3 PLC	±.005 [0.13]	4 PLC	±	ANGLES	±	APPLICATION SPEC	
0 PLC	±														
1 PLC	±														
2 PLC	±														
3 PLC	±.005 [0.13]														
4 PLC	±														
ANGLES	±														
MATERIAL SEE CALLOUTS		WEIGHT -	SIZE A2	CAGE CODE 00779											
FINISH SEE CALLOUTS		DRAWING NO 1218699		RESTRICTED TO -											
CUSTOMER DRAWING		SCALE 15:1	SHEET 1 OF 1	REV A											

单击下面可查看定价，库存，交付和生命周期等信息

[>>TE Connectivity\(泰科\)](#)