

- △ HOUSING: POLYESTER, UL 94V-0 RATED, BLACK.  
CONTACT: PHOSPHOR BRONZE.  
SCREWLOCK: BRASS.  
SHELL: CARBON STEEL.
- △ SHELL: 5.08um [.000200] MIN TIN OVER 2.54um [.000100] MIN COPPER.  
CONTACT: 0.76um [.000030] MIN GOLD FOR A LENGTH OF 1.40 [.055] MIN FROM MATING END, 2.54um [.000100] MIN TIN OR TIN-LEAD ON OPPOSITE END, BOTH OVER 0.76um [.000030] MIN NICKEL.  
SCREWLOCK: 2.54um [.000100] MIN TIN-LEAD OVER 1.27um [.000050] MIN NICKEL OVER COPPER FLASH.
- 3. NOTE DELETED.
- △ DATUMS AND BASIC DIMENSIONS ESTABLISHED BY CUSTOMER.
- △ 2.79[.110] MAX IN SHELL TAB CLINCH AREAS.
- △ ORIENTATION IS OPTIONAL AND MAY NOT BE AS SHOWN.

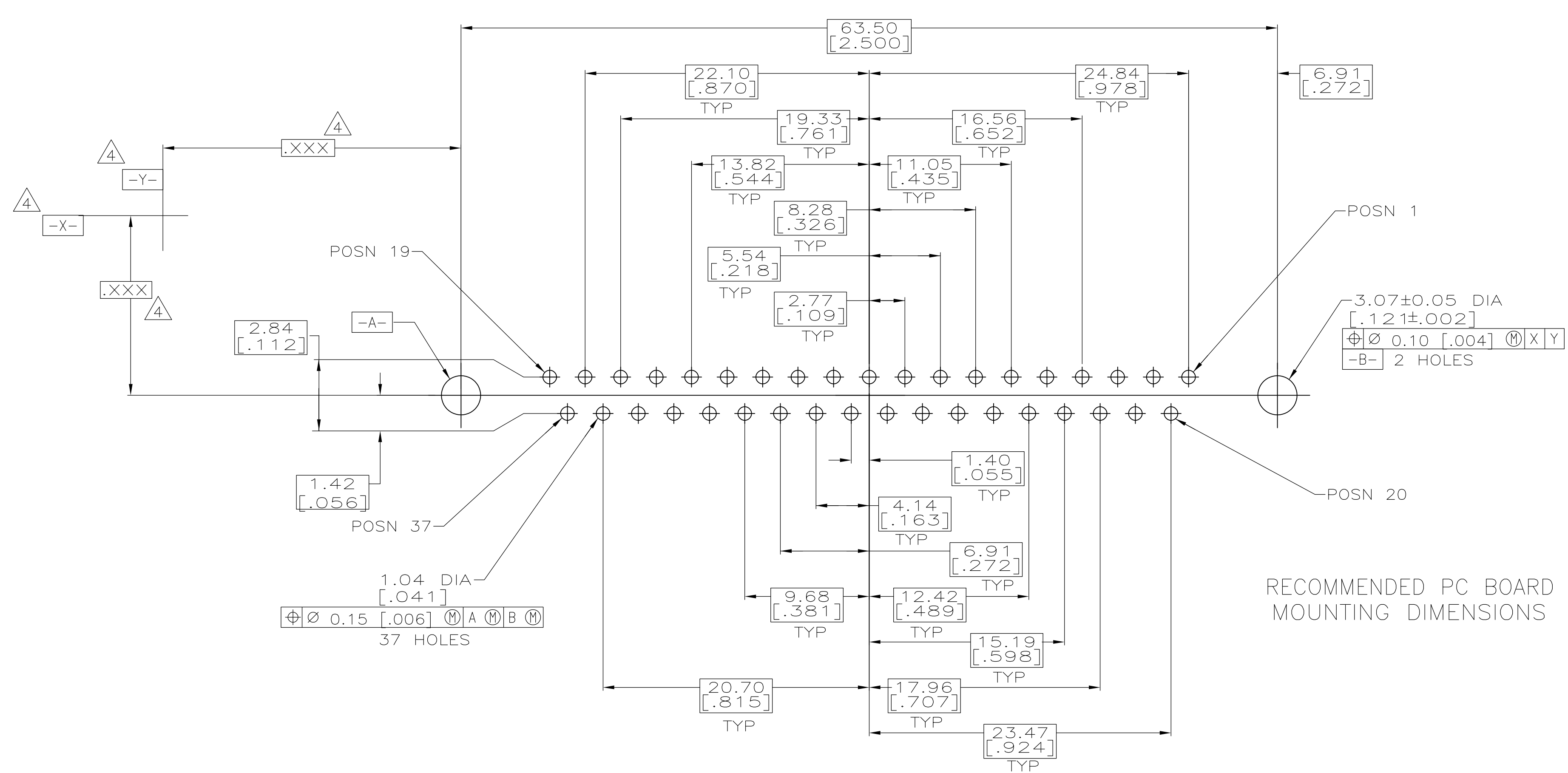
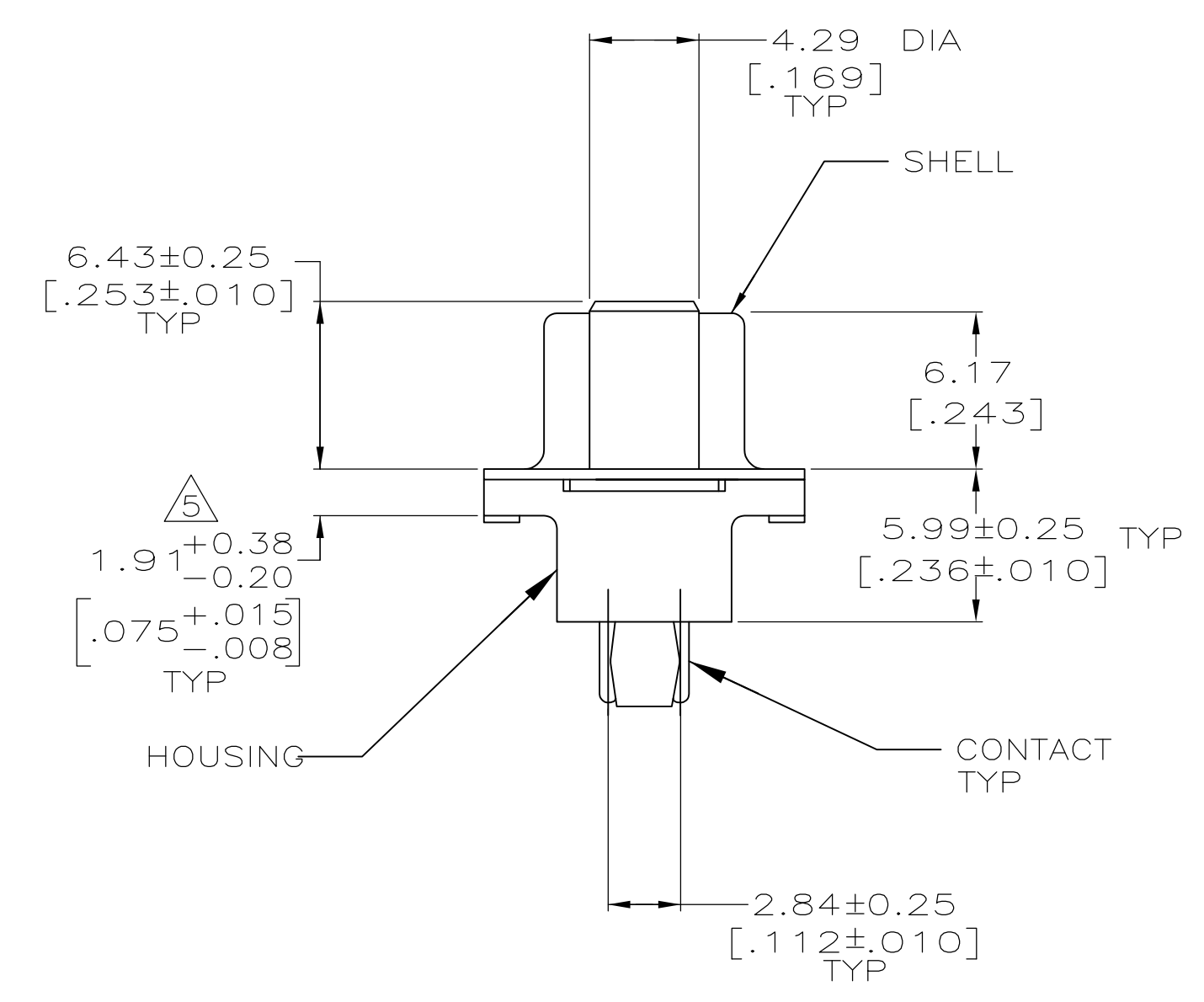
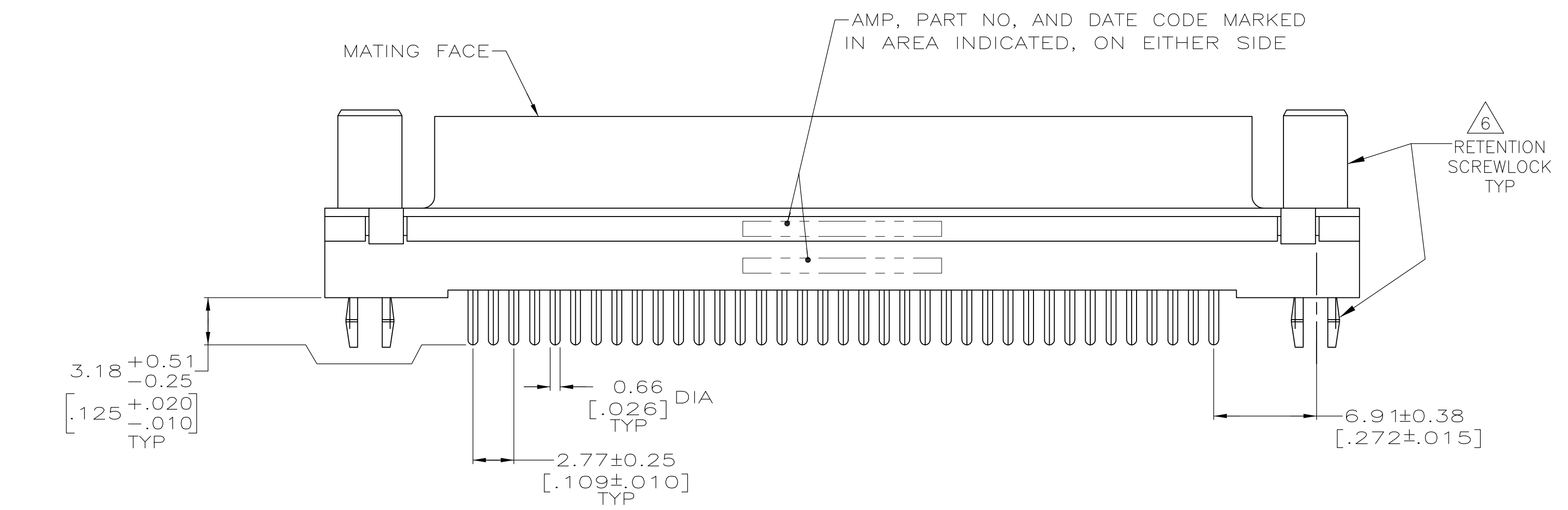

RECOMMENDED PC BOARD MOUNTING DIMENSIONS

787685-1  
PART NUMBER

THIS DRAWING IS A CONTROLLED DOCUMENT.		DIN C. OBERMAN 12 FEB 96	Tyco Electronics Corporation Harrisburg, PA 17105-3608
DIMENSIONS: mm [INCHES]		CHK R. STONE 15 FEB 96	
TOLERANCES UNLESS OTHERWISE SPECIFIED:		APP'D B. TAYLOR 15 FEB 96	NAME
0. PLC ± -	1. PLC ± -	PRODUCT SPEC	
2. PLC ± 0.13 [.005]	3. PLC ± -	108-40025	
4. PLC ± -	ANGLES ± -	APPLICATION SPEC	
MATERIAL		WEIGHT	SIZE CASE CODE DRAWING NO
FINISH		A1 00779 C=787685	RESTRICTED TO
CUSTOMER DRAWING		SCALE 4:1	SHEET 1 OF 1 REV F

单击下面可查看定价，库存，交付和生命周期等信息

[>>TE Connectivity\(泰科\)](#)