

THIS DRAWING IS UNPUBLISHED. RELEASED FOR PUBLICATION  
 © COPYRIGHT 2017 TE Connectivity ALL RIGHTS RESERVED.

REVISIONS				
P	LTR	DESCRIPTION	DATE	APVD
	A	RELEASE TO PRODUCTION	18 JUN 2020	AY PS

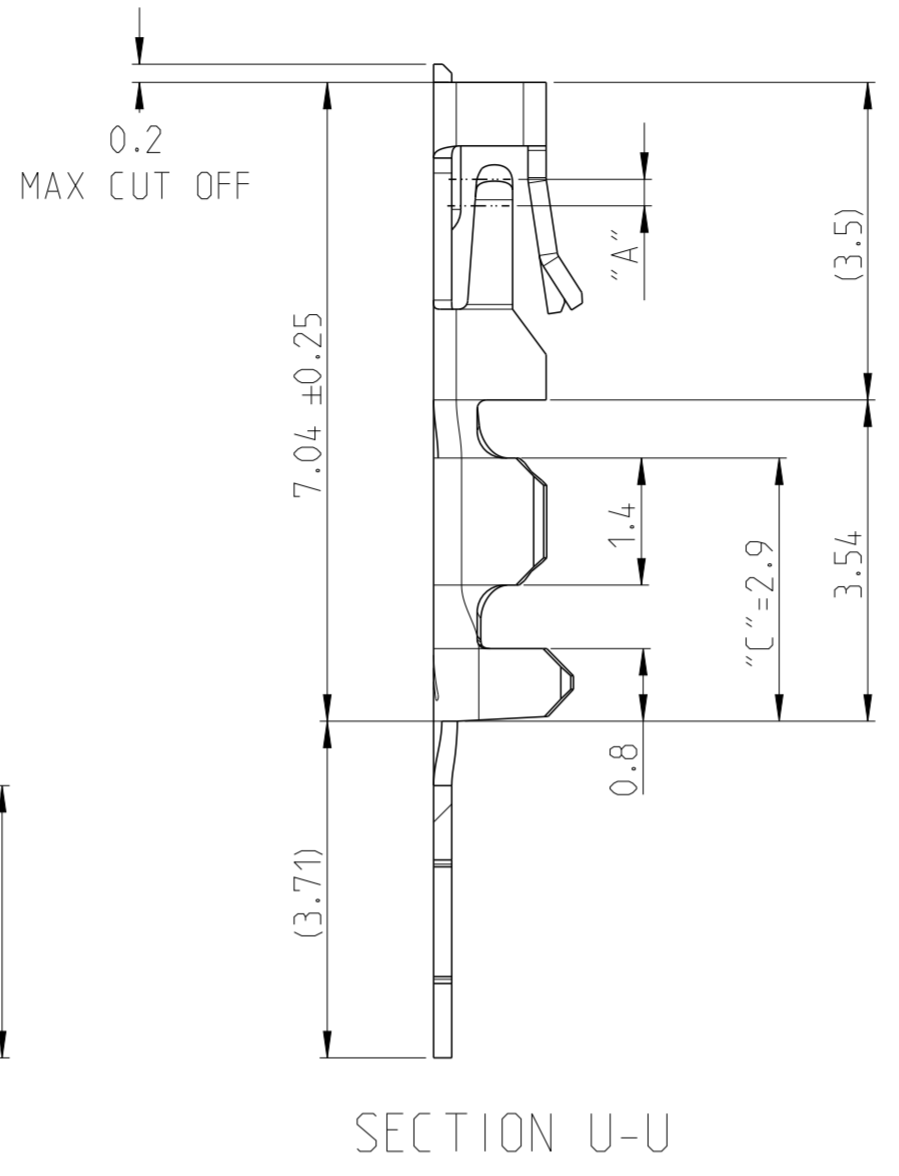

- NOTES:
- 1 MATERIAL: PHOSPHOR BRONZE, 0.2mm THICK
  - 2 FINISH: 1.27-2.54 μm TIN ALL OVER UNDERPLATE 1.27 μm MIN NICKEL ALL OVER
  - 3 CONTACT AREA "A": MIN 0.1 μm THK GOLD CRIMP AREA "C" : 1.27 - 2.54 μm THK TIN UNDERPLATE 1.27 μm MIN NICKEL ALL OVER
  - 4 CONTACT AREA "A" : MIN 0.38 μm THK GOLD CRIMP AREA "C" : 1.27 - 2.54 μm THK TIN UNDERPLATE 1.27 μm MIN NICKEL ALL OVER
  - 5 CONTACT AREA "A" : MIN 0.76 μm THK GOLD CRIMP AREA "C" : 1.27 - 2.54 μm THK TIN UNDERPLATE 1.27 μm MIN NICKEL ALL OVER
  - 6. APPLICABLE HOUSINGS :  
 SINGLE ROW : 2316102  
 DUAL ROW : 2316108, 2316109

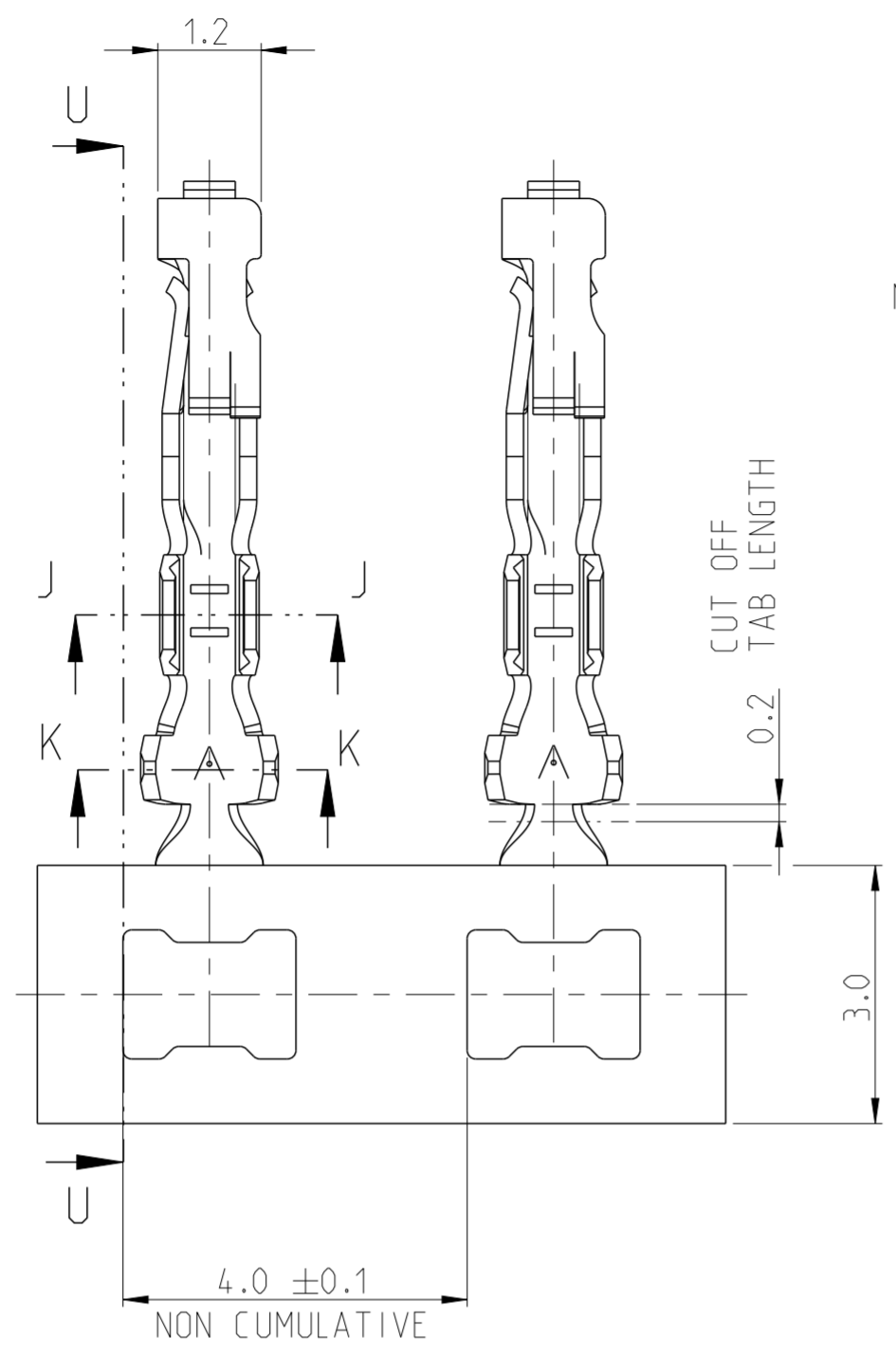
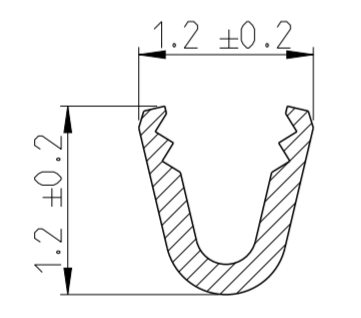

SECTION J-J  
20:1

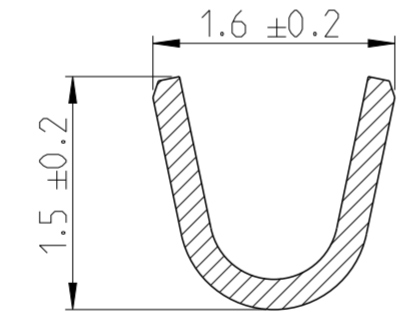

SECTION K-K  
20:1

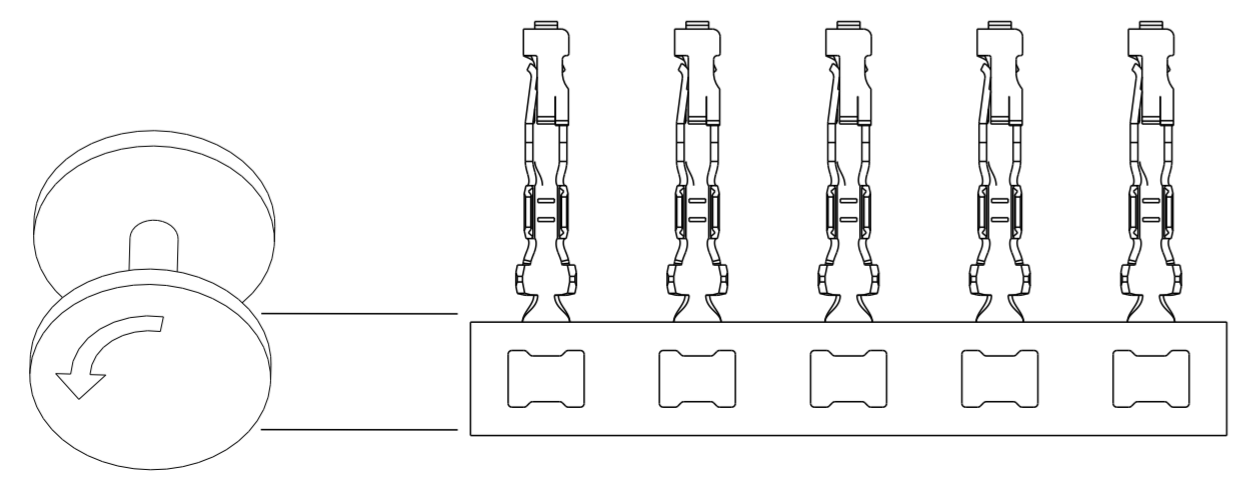

(CRIMP UP)

WIRE RANGE: 0.05-0.08 mm<sup>2</sup> (30-28 AWG)  
 INSULATION RANGE: Ø0.5-Ø1.0mm

5	-	5-2316114-6	LOOSE PIECE - HANDTOOL
5	30,000	5-2316114-5	FOR OCEAN APPLICATOR
4	-	4-2316114-5	LOOSE PIECE - HANDTOOL
4	30,000	4-2316114-4	FOR OCEAN APPLICATOR
3	-	3-2316114-4	LOOSE PIECE - HANDTOOL
3	30,000	3-2316114-3	FOR OCEAN APPLICATOR
2	-	2-2316114-3	LOOSE PIECE - HANDTOOL
2	30,000	2-2316114-2	FOR OCEAN APPLICATOR
FINISH	QTY PER REEL	PART NUMBER	TOOLING

THIS DRAWING IS A CONTROLLED DOCUMENT.

DWN SOURAV DAS 29OCT2017	 TE Connectivity AMPMODU 2mm RECEPTACLE, wTB CRIMP CONTACT, AWG 30-28			
CHK RAKSHITH R NAYAK 29OCT2017				
APVD PRASHANTH 08DEC2017				
PRODUCT SPEC 108-64040-1				
APPLICATION SPEC 114-32173	NAME			
MATERIAL SEE NOTE	SIZE A2	CAGE CODE 00779	DRAWING NO C-2316114	RESTRICTED TO
FINISH	WEIGHT	SCALE 5:1	SHEET 1 OF 1	REV A
CUSTOMER DRAWING				

单击下面可查看定价，库存，交付和生命周期等信息

[>>TE Connectivity\(泰科\)](#)