

DUAL CRIMP TABLE	
PART NO	WIRE SIZE
1326030-9 AND 1-1326030-1	0.35+0.35
	0.35+0.5
	0.35+0.75
	0.35+1.0
	0.5+0.5
1-1326030-0 AND 1-1326030-2	0.5+0.75
	0.35+1.5
	0.5+1.0
	0.5+1.5
	0.75+0.75
0.75+1.0	
0.75+1.5	
1.0+1.0	
1.0+1.5	

REVISIONS				
P	LTN	DESCRIPTION	DATE	OWN APVD
H2		REVISED PER ECO-11-005030	26APR2011	RK HMR
H3		REVISED PER ECO-15-012018	19AUG2015	DLD SLM

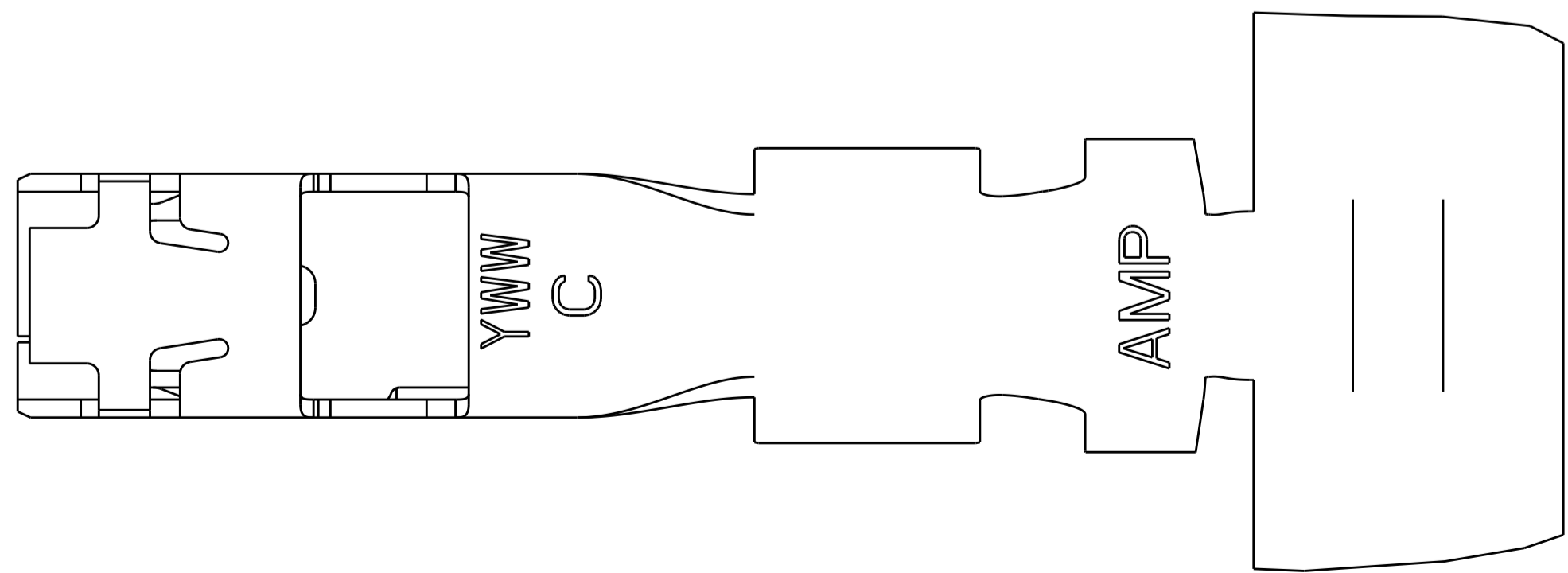

△ MATERIAL: 0.30 THICK COPPER ALLOY, PREPLATED WITH 0.0008 MINIMUM THICK REFLOW TIN OR BRIGHT TIN (ELV COMPLIANT).
 ALTERNATE MATERIAL: 0.30 THICK COPPER ALLOY, PREPLATED WITH 0.0008 MINIMUM THICK BRIGHT TIN (ELV COMPLIANT).

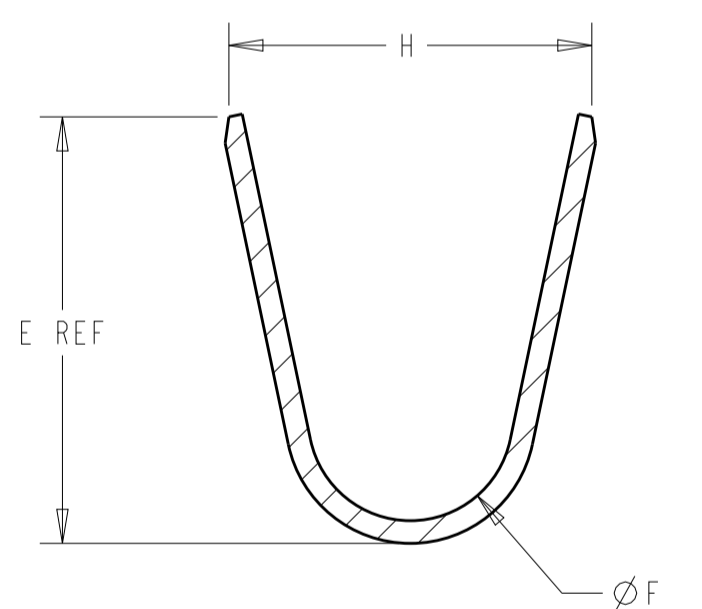
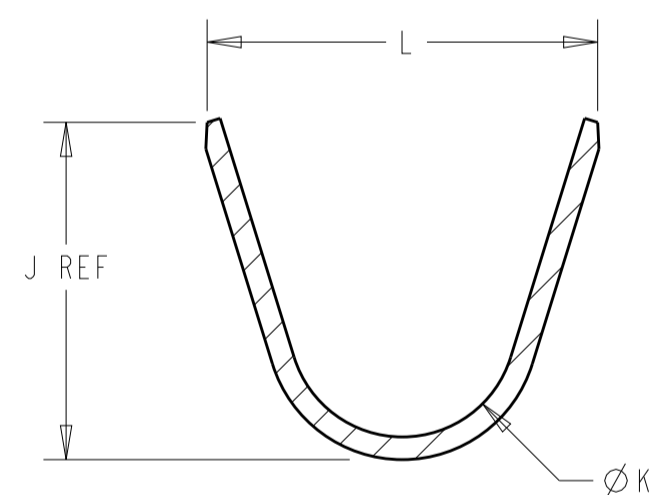
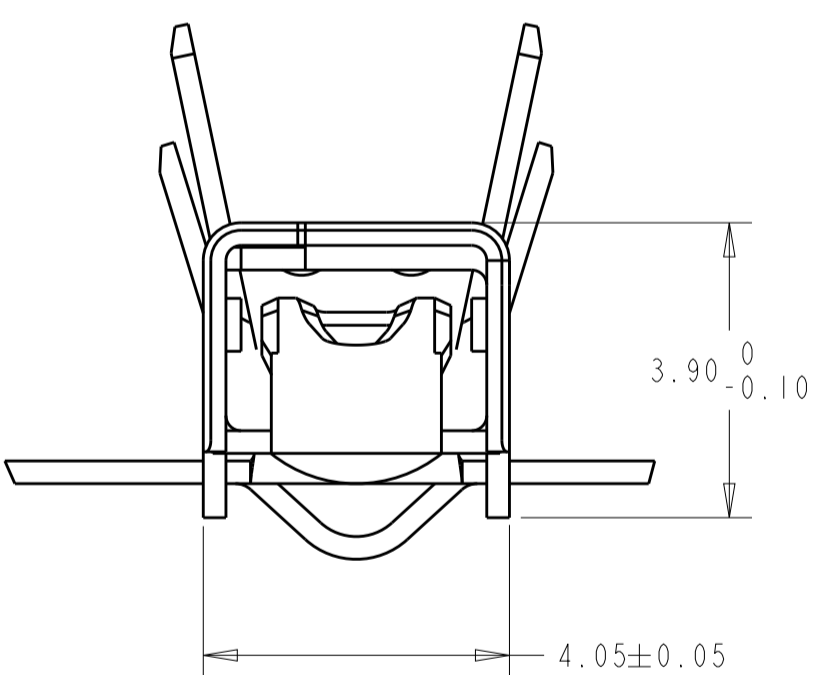
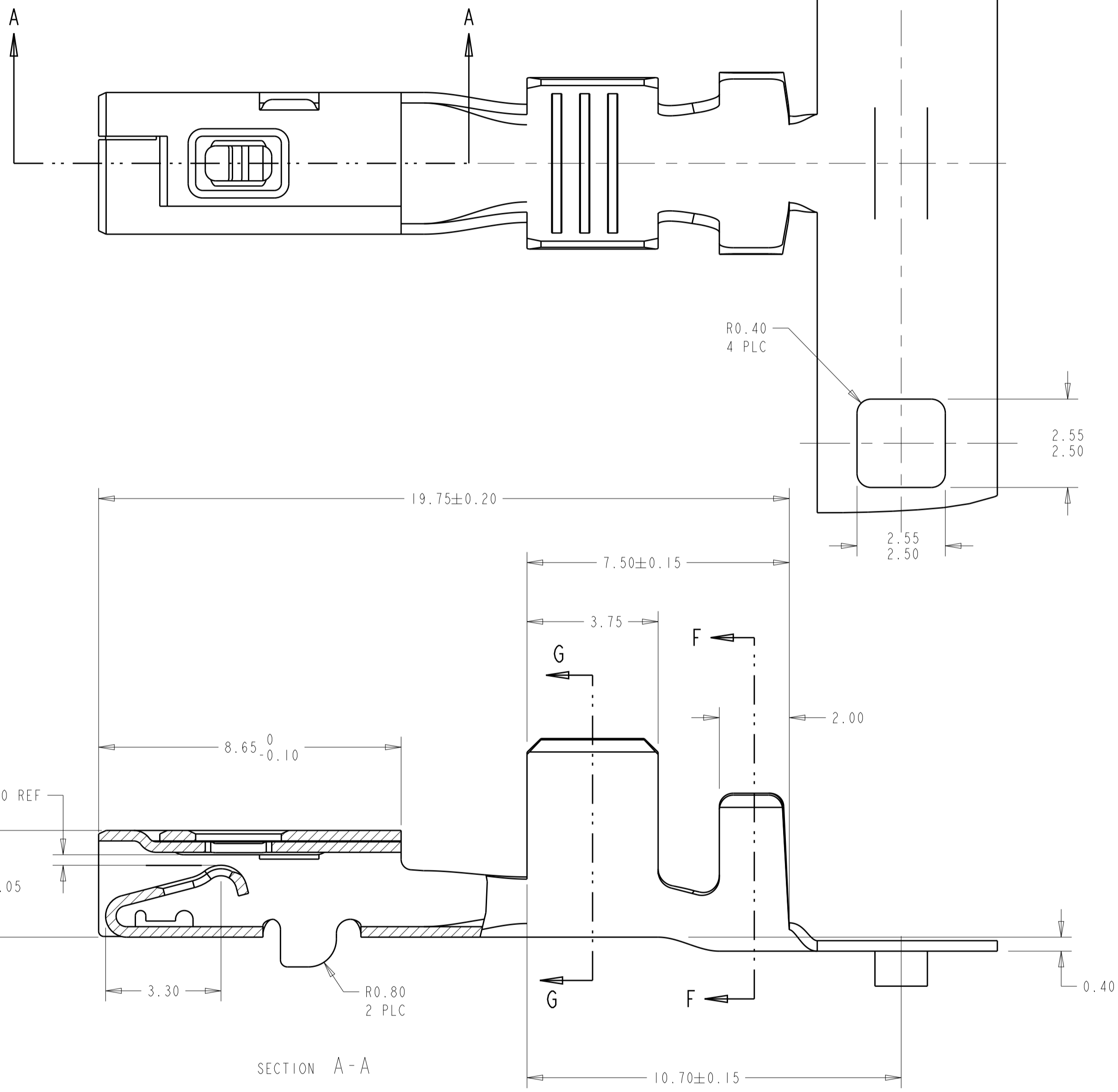
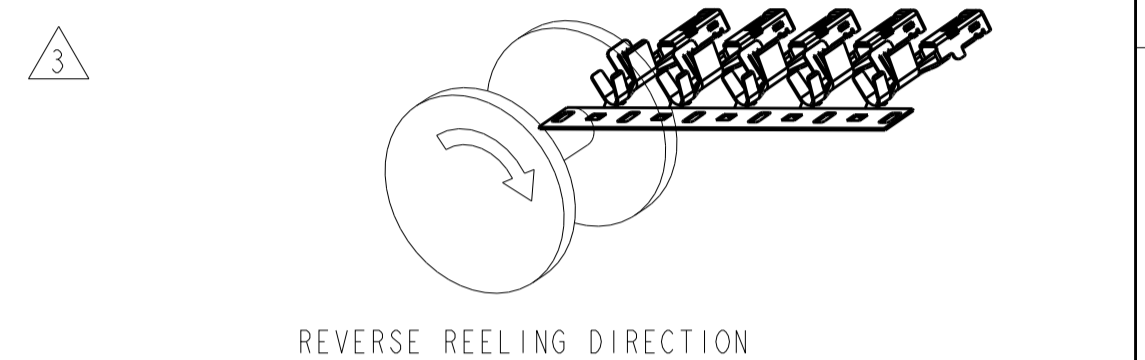
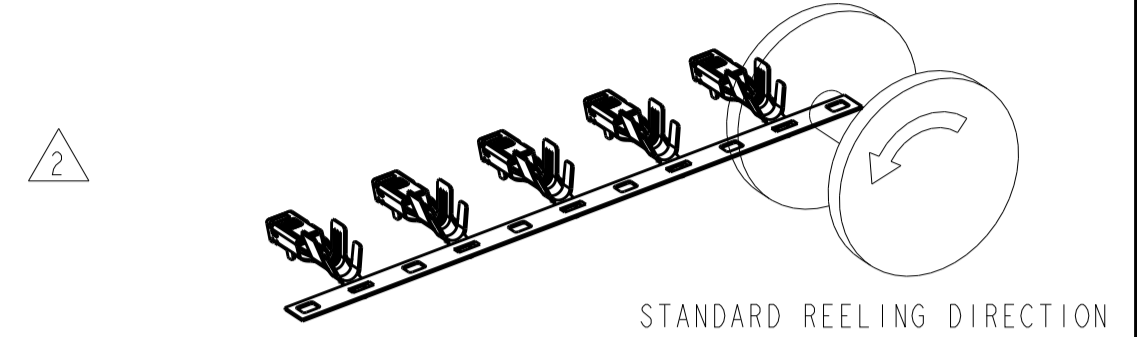

5. QUALIFICATION OF THE CRIMP APPLICATION TOOLING SHALL BE CONTROLLED BY THE REQUIREMENTS ESTABLISHED UNDER USCAR 21.
 6. LOOSE END SPLICING TO BE USED.

3	1-1326030-0 REELED FOR AMP APPLICATOR						REFERENCE DUAL CRIMP TABLE	1-1326030-2	
	1326030-9 REELED FOR AMP APPLICATOR						REFERENCE DUAL CRIMP TABLE	1-1326030-1	
2	4.6	1.80	5.35	3.9	1.70	3.88	REFERENCE DUAL CRIMP TABLE	1-1326030-0	
	3.6	1.40	4.32	3.3	1.30	2.76	REFERENCE DUAL CRIMP TABLE	1326030-9	
3	1326030-4 REELED FOR AMP APPLICATORS						12 AWG	1326030-8	
	1326030-3 REELED FOR AMP APPLICATORS						14-16 AWG	1326030-7	
	1326030-2 REELED FOR AMP APPLICATORS						18-20 AWG	1326030-6	
	1326030-1 REELED FOR AMP APPLICATORS						22 AWG	1326030-5	
2	5.2	3.20	4.22	4.7	2.70	5.25	12 AWG	1326030-4	
	3.8	1.80	3.16	3.9	1.70	3.88	14-16 AWG	1326030-3	
	3.1	1.40	2.55	3.3	1.30	2.76	18-20 AWG	1326030-2	
	2.6	1.00	2.04	2.5	0.90	2.11	22 AWG	1326030-1	
REELING		L	ØK	J	H	ØF	E	WIRE SIZE	PART NUMBER

THIS DRAWING IS A CONTROLLED DOCUMENT.

APVD: D. BROWN, 28APR99

CHK: D. BROWN, 28APR99

DWN: D. STRAUSSER, 28APR99

NAME: RECEPTACLE, 2.8mm, UNSEALED

PRODUCT SPEC: SAE/USCAR-2 8/97

APPLICATION SPEC: 114-13013

SIZE: A1, CAGE CODE: 00779, DRAWING NO: 1326030

RESTRICTED TO: H3

SCALE: 10:1, SHEET: 1 OF 1, REV: H3

CUSTOMER DRAWING

单击下面可查看定价，库存，交付和生命周期等信息

[>>TE Connectivity\(泰科\)](#)