

LOC	DIST	REVISIONS			
F	LVR	DESCRIPTION	DATE	DWN	APVD
	F	REVISED PER 0G3B-0208-05	25APR05	KW	C.J

- △ MATERIAL:
CONTACTS - BRASS.
HOUSING - UL 94V-0 RATED HIGH TEMP NYLON, COLOR; BLACK.
- △ PLATING:
CONTACTS - 0.38μm MINIMUM GOLD OVER 2.54μm MINIMUM NICKEL
ON MATING AREA. 2.54μm TIN-LEAD MINIMUM OVER 2.54μm NICKEL
MINIMUM ON SOLDER TAILS.
- △ DIMENSION APPLIES TO SOLDER TAIL SURFACES
AND STANDOFF SURFACES.
- △ RECOMMENDED PC BOARD THICKNESS OF 1.57.
- △ ALL SOLDER TAILS.
- △ PLATING:
CONTACTS - 0.38μm MINIMUM GOLD OVER 2.54μm MINIMUM NICKEL
ON MATING AREA. 2.54μm MATTE TIN MINIMUM OVER 2.54μm NICKEL
MINIMUM ON SOLDER TAILS.

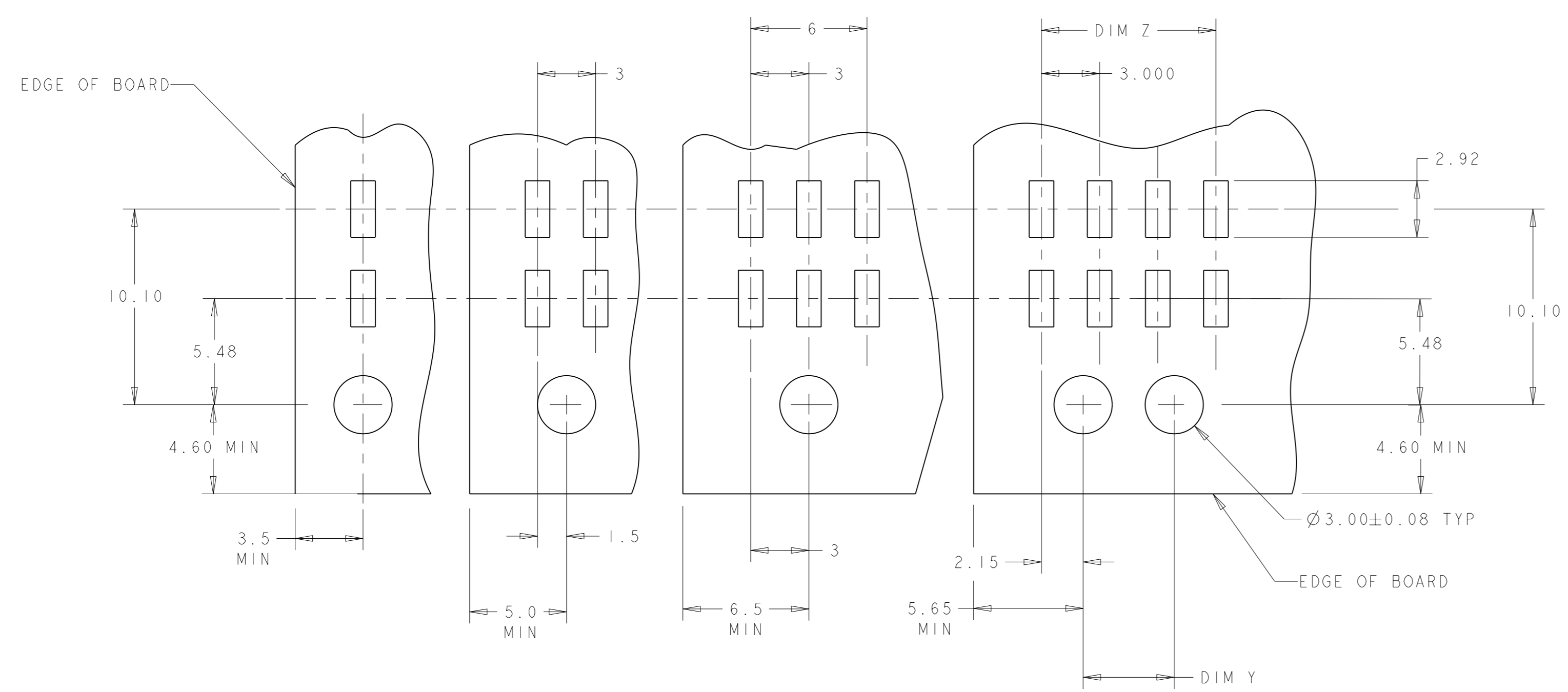

RECOMMENDED PCB LAYOUT (COMPONENT SIDE) △

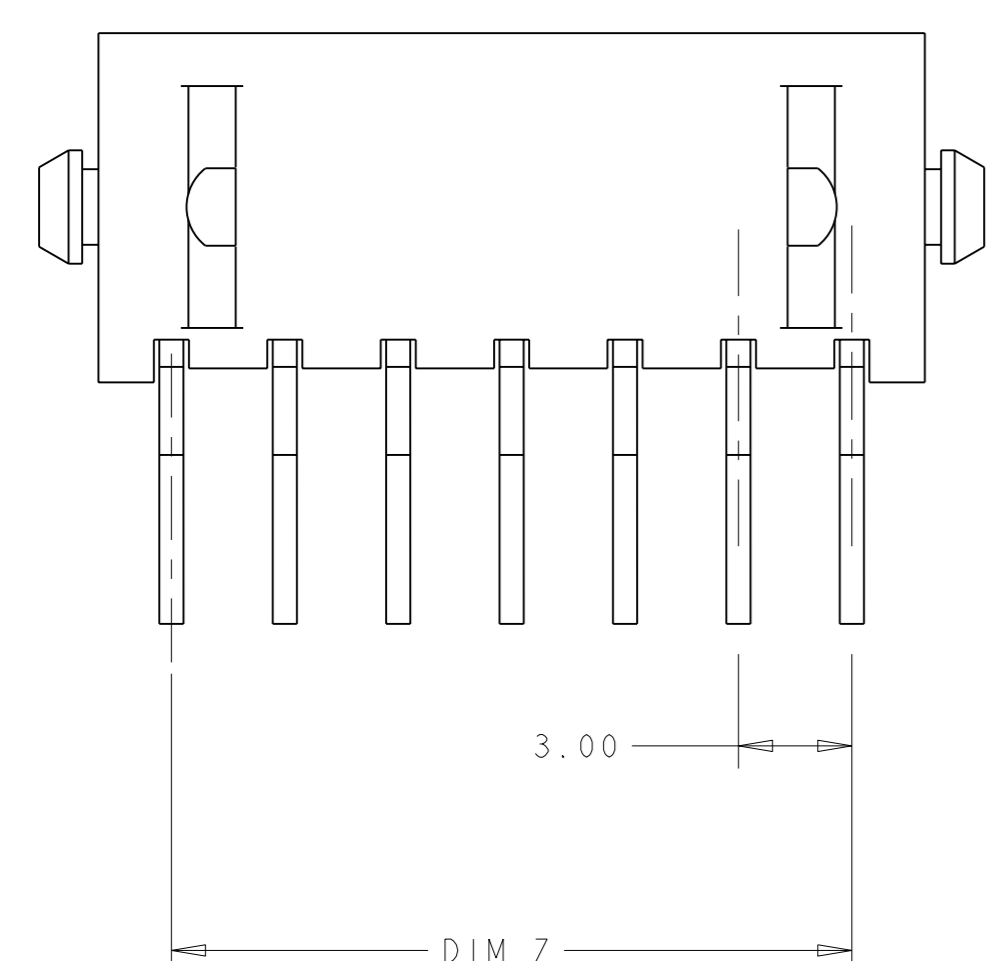
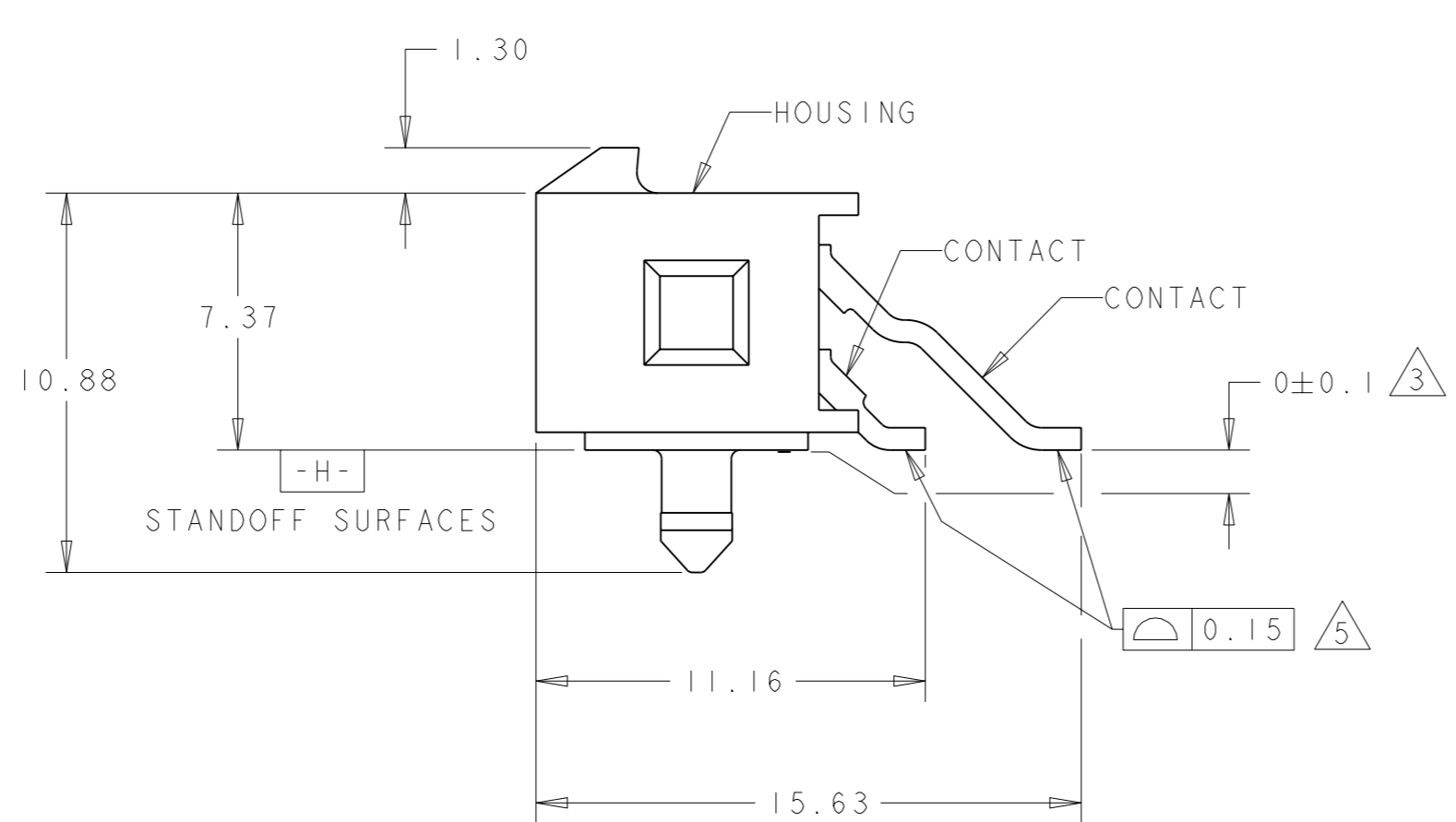
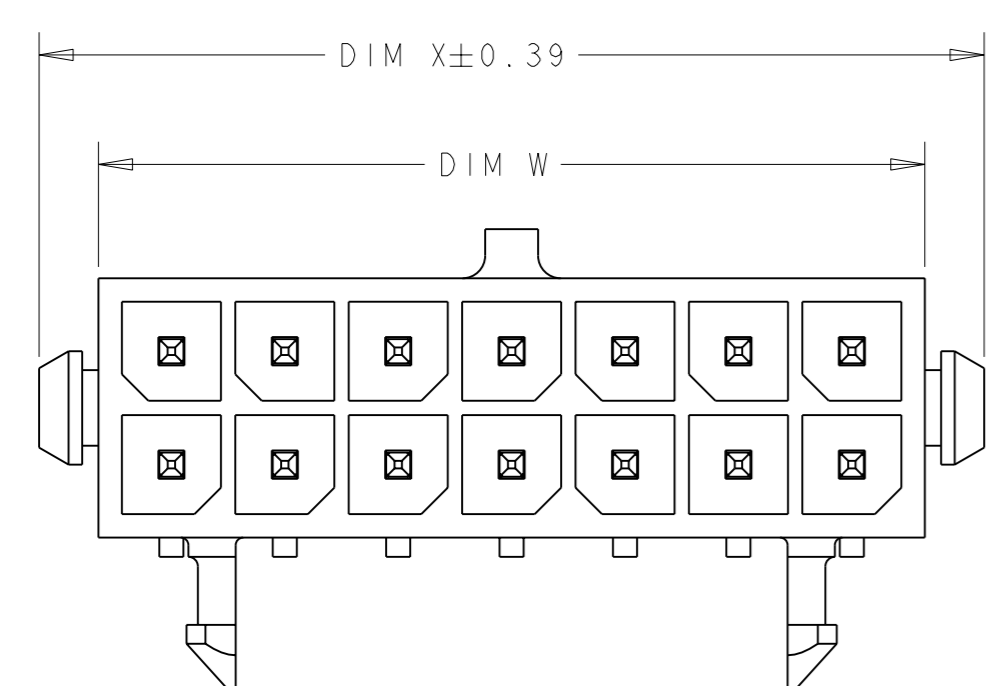
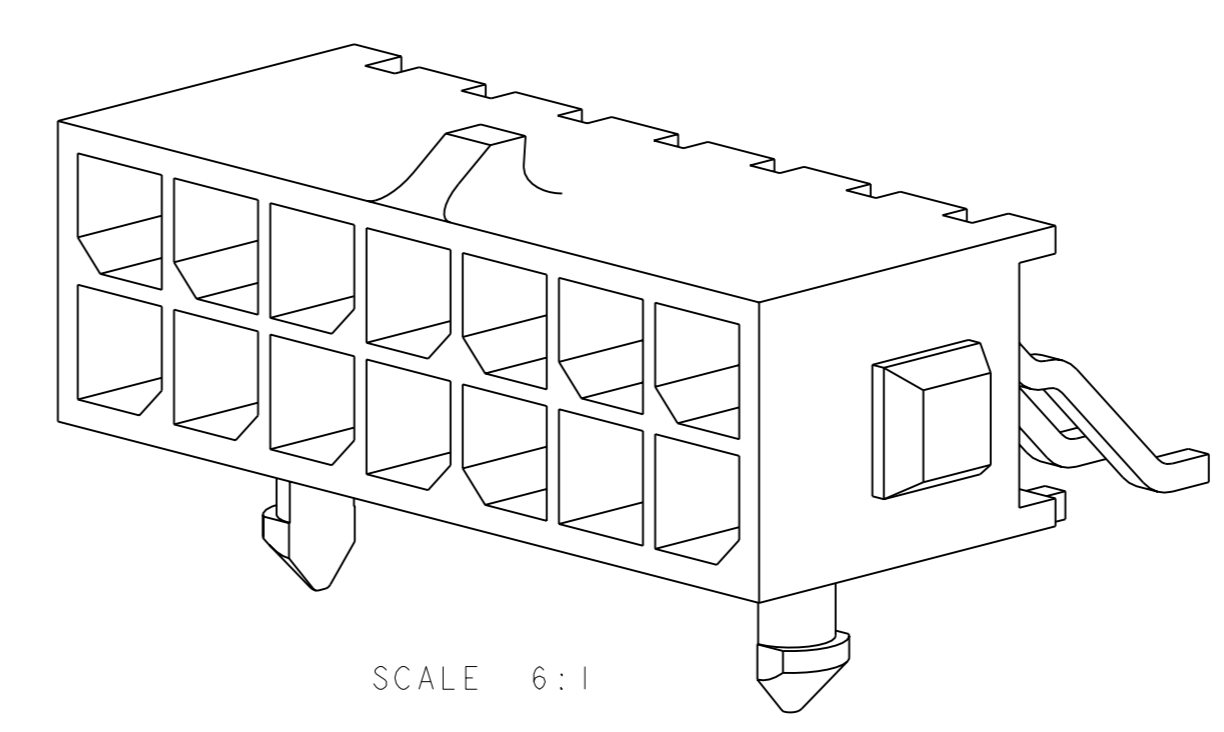

SCALE 6:1

FINISH	DIM W	DIM Y	DIM Z	DIM X	NO. OF POSN.	PART NUMBER
△	36.86	28.70	33.00	40.00	24	5-794622-4
△	33.86	25.70	30.00	37.00	22	5-794622-2
△	30.86	22.70	27.00	34.00	20	5-794622-0
△	27.86	19.70	24.00	31.00	18	4-794622-8
△	24.86	16.70	21.00	28.00	16	4-794622-6
△	21.86	13.70	18.00	25.00	14	4-794622-4
△	18.86	10.70	15.00	22.00	12	4-794622-2
△	15.86	7.70	12.00	19.00	10	4-794622-0
△	12.86	4.70	9.00	16.00	8	3-794622-8
△	9.86	-	6.00	13.00	6	3-794622-6
△	6.86	-	3.00	10.00	4	3-794622-4
△	3.86	-	-	7.00	2	3-794622-2
△	36.86	28.70	33.00	40.00	24	2-794622-4
△	33.86	25.70	30.00	37.00	22	2-794622-2
△	30.86	22.70	27.00	34.00	20	2-794622-0
△	27.86	19.70	24.00	31.00	18	1-794622-8
△	24.86	16.70	21.00	28.00	16	1-794622-6
△	21.86	13.70	18.00	25.00	14	1-794622-4
△	18.86	10.70	15.00	22.00	12	1-794622-2
△	15.86	7.70	12.00	19.00	10	1-794622-0
△	12.86	4.70	9.00	16.00	8	794622-8
△	9.86	-	6.00	13.00	6	794622-6
△	6.86	-	3.00	10.00	4	794622-4
△	3.86	-	-	7.00	2	794622-2

DIMENSIONS: mm		TOLERANCES UNLESS OTHERWISE SPECIFIED:		DWN: K. WHITAKER 28 JAN 2002		Tyco Electronics Harrisburg, PA 17105-3608	
0 PLC	±	1 PLC	±0.13	CHK: C. JONES 28 JAN 2002	NAME: SURFACE MOUNT, R/A, 15 GOLD HEADER, PLASTIC BOARDLOCK, DUAL ROW, MICRO MATE-N-LOK™	SIZE: A	RESTRICTED TO:
2 PLC	±	3 PLC	±	APVD: C. JONES 28 JAN 2002	PRODUCT SPEC:	SCALE: 5:1	SHEET 1 OF 1
4 PLC	±	ANGLES:	±	APPLICATION SPEC:	NO. OF POSN.: 24	REV: F	
MATERIAL:	SEE TABLE	FINISH:	SEE TABLE	WEIGHT:	00779		
				CUSTOMER DRAWING			

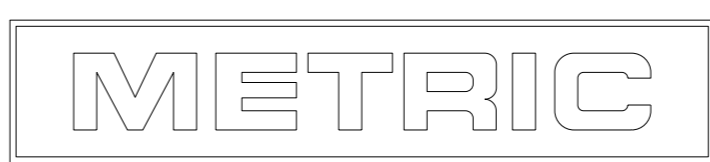

单击下面可查看定价，库存，交付和生命周期等信息

[>>TE Connectivity\(泰科\)](#)