

THIS DRAWING IS UNPUBLISHED. RELEASED FOR PUBLICATION  
 © COPYRIGHT BY TYCO ELECTRONICS CORPORATION. ALL INTERNATIONAL RIGHTS RESERVED.

LOC	DIST	REVISIONS			
P	LTR	DESCRIPTION	DATE	DWN	APVD
G	14	A1	REV PER ECR 10-013673	29JUN10	JR TM

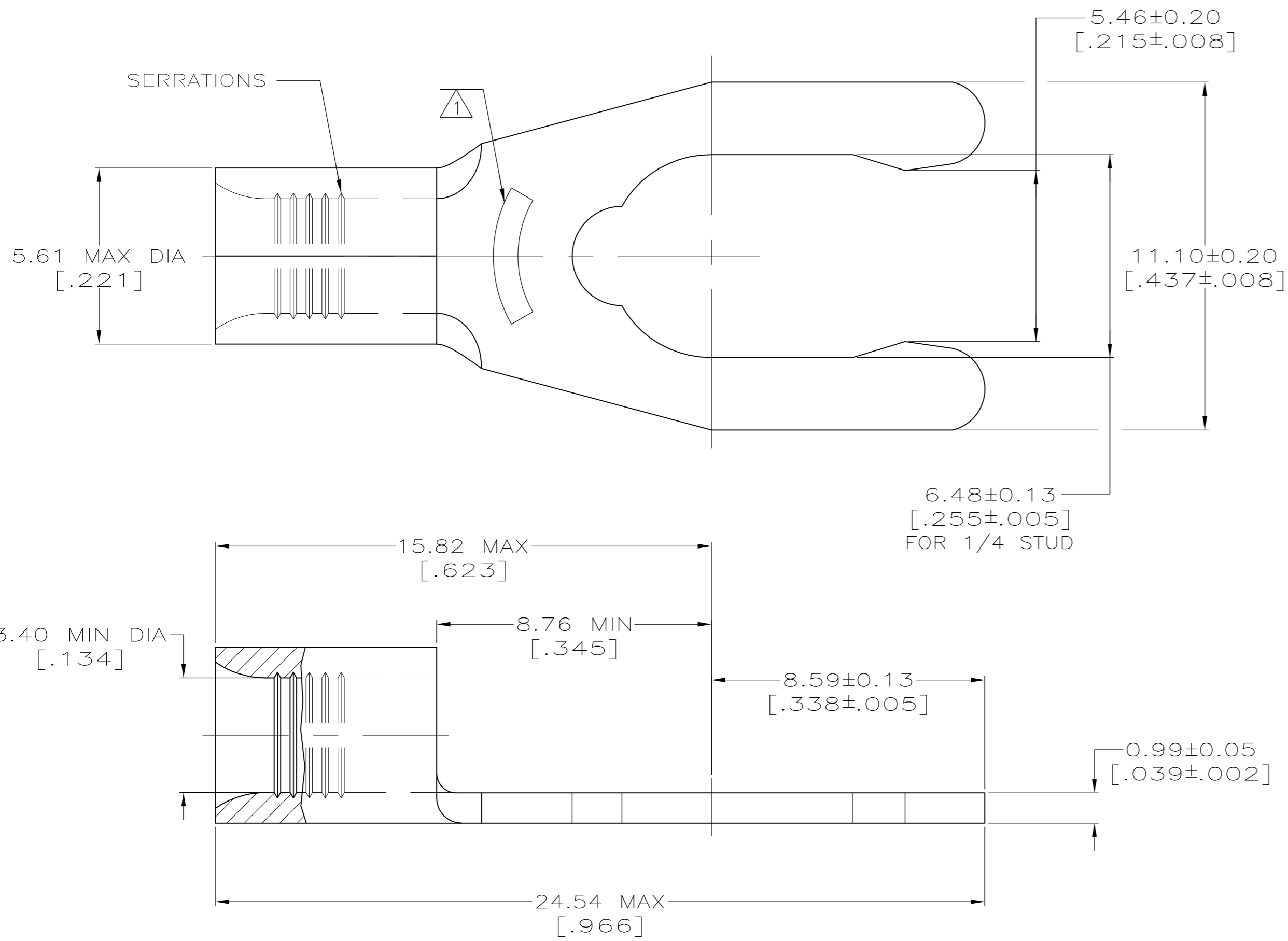

<b>AMP</b> WIRE RANGE	Listed FILE E13288	LR7189 Certified
12-10 AWG STRANDED	12-10 AWG STRANDED	NOT CERTIFIED

- 1 STAMP 1/4S AMP 12-10\* APPROX AS SHOWN  
1/4S INDICATES STUD SIZE
- 2 PHOSPHOR BRONZE PER ASTM B-103, ANNEALED
- 3 TIN PLATE 0.00254 [.000100] MIN PER ASTM B545

52772

B

A

52772-1  
PART NO.

MAX RECOMMENDED OPERATING TEMPERATURE: 170°C MAX	THIS DRAWING IS A CONTROLLED DOCUMENT.		DWN TA BRINKMAN 2-16-93	Tyco Electronics Corporation Harrisburg, PA 17105-3608
	VOLTAGE RATING: N/A	DIMENSIONS: MM [ INCHES ]	CHK DA PATTERSON 2-16-93	
CIRCULAR MIL AREA: 2.62-6.64mm² [5,180-13,100] STRANDED		TOLERANCES UNLESS OTHERWISE SPECIFIED: 0 PLC ± - 1 PLC ± - 2 PLC ± - 3 PLC ± - 4 PLC ± - ANGLES ± - FINISH	APVD JL MECKLEY 2-16-93	NAME TERMINAL, LONG SPRING SPADE, BUDGET
			MATERIAL - 2	FINISH - 3
			CAGE CODE 00779	DRAWING NO C=52772
			SCALE 8:1	SHEET 1 of 1
			CUSTOMER DRAWING	REV A1

单击下面可查看定价，库存，交付和生命周期等信息

[>>TE Connectivity\(泰科\)](#)