

© COPYRIGHT - By - ALL RIGHTS RESERVED.

P	LTR	DESCRIPTION	DATE	DWN	APVD
	J2	REVISED PER ECO-13-008676	23MAY13	KH	DR
	J3	REVISED PER ECO-17-014333	16OCT2017	RS	DR

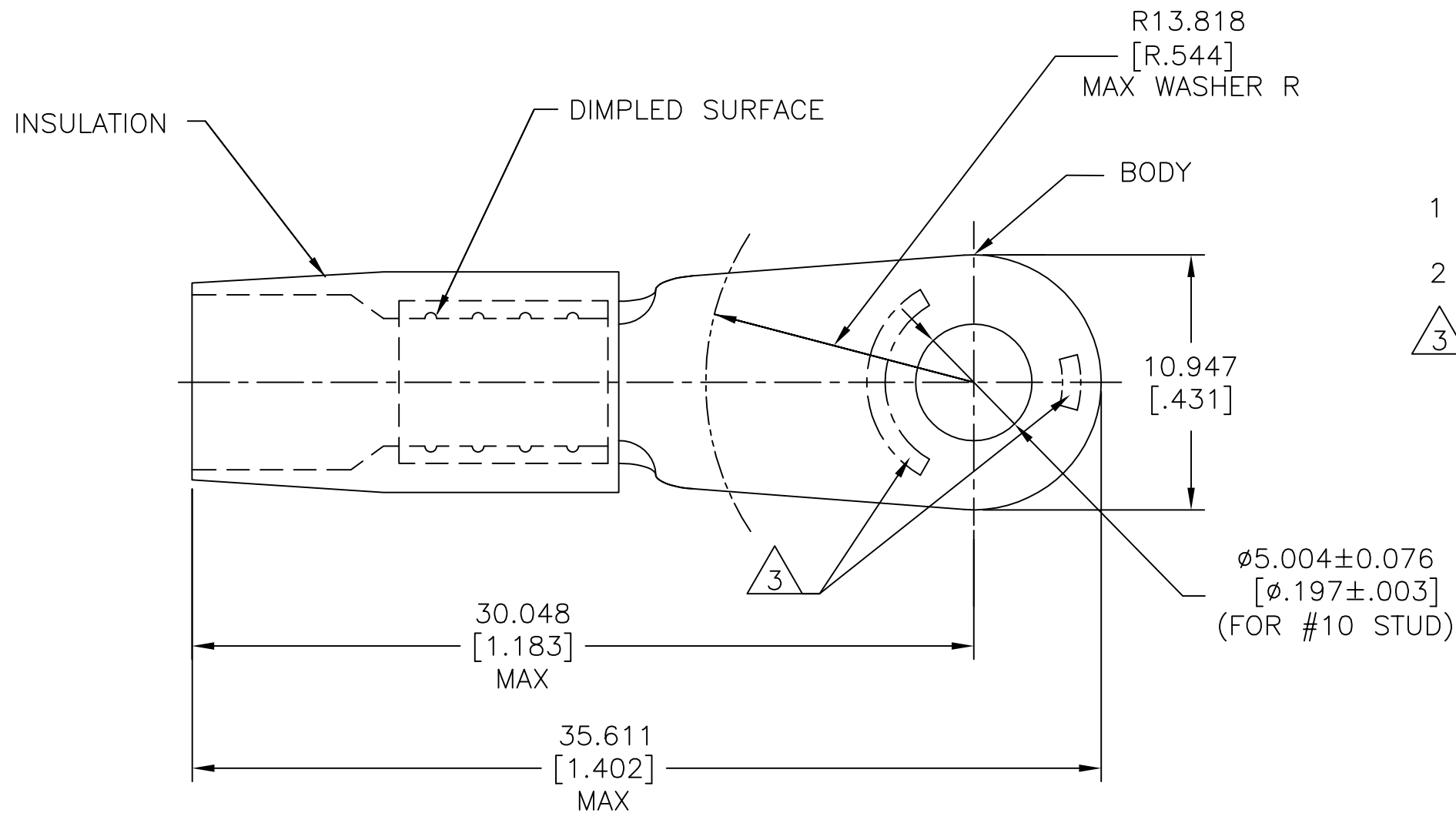
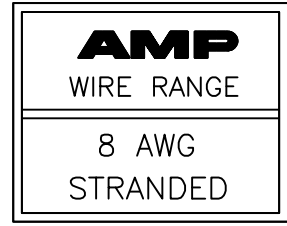

- 1 BODY MATERIAL THK 0.991±0.051[.039±.002]
- 2 FOR  $\phi 6.502[\phi .256]$  MAX WIRE INS.
- △ 3 STAMP AMP 8\* 14 APPROX AS SHOWN.

MS25036-115 CLASS 2	100	LOOSE PC	324043
MILITARY P/N AND CLASS	QTY	PACKAGE TYPE	PART NO

AMP INCORPORATED CUSTOMER SERVICE SYSTEMS		MAX RECOMMENDED OPERATING TEMPERATURE: 105°C[221°F]	THIS DRAWING IS A CONTROLLED DOCUMENT.		DWN S.S. GOULDEN 6-18-93	TE Connectivity NAME TERMINAL, RING TONGUE, TERMINYL WIRE SIZE: 8 AWG						
FOR ADDITIONAL PRODUCT INFORMATION OR COPIES OF DRAWINGS AND TECHNICAL DOCUMENTS	PRODUCT INFORMATION CENTER 1-800-522-6752	VOLTAGE RATING: -	DIMENSIONS: mm [INCHES]	TOLERANCES UNLESS OTHERWISE SPECIFIED:	CHK R. HERSEY 6-18-93					SAE AS7928		
FOR APPLICATION TOOLING INFORMATION	TOOLING ASSISTANCE CENTER 1-800-722-1111	CIRCULAR MIL AREA: 6.64-10.5mm <sup>2</sup> [13.100-20.800] STRANDED		0 PLC ± -	APVD B. BARE 6-18-93	APPLICATION SPEC						
FOR ORDER ENTRY	1-800-526-5142	THIS DRAWING IS A CONTROLLED DOCUMENT FOR AMP INCORPORATED. IT IS SUBJECT TO CHANGE AND THE CONTROLLING ENGINEERING ORGANIZATION SHOULD BE CONTACTED FOR THE LATEST REVISION.		MATERIAL COPPER PER ASTM B-152 NYLON ASTM D4066 TYPE 1 COLOR: RED	1 PLC ± -	PRODUCT SPEC	SIZE CAGE CODE DRAWING NO RESTRICTED TO					
				2 PLC ± -	WEIGHT	A3 00779 C-324043						
				3 PLC ± 0.127[.005]	CUSTOMER DRAWING					SCALE	SHEET	REV
				4 PLC ± -						NTS	1 OF 1	J3
				ANGLES ± -								

单击下面可查看定价，库存，交付和生命周期等信息

[>>TE Connectivity\(泰科\)](#)