

THIS DRAWING IS UNPUBLISHED. RELEASED FOR PUBLICATION APRIL ,2004.
 © COPYRIGHT 2004 BY TYCO ELECTRONICS CORPORATION. ALL RIGHTS RESERVED.

LOC	DIST	REVISIONS					
E	B	P	LTR	DESCRIPTION	DATE	DWN	APVD
		A		EBD0-0035-03	30JAN04	RS	FWK

- NOTES:
- 1 SINGLE PACK IN ACCORDANCE WITH SPEC 107-3275
 - 2 100 TRAY PACK IN ACCORDANCE WITH SPEC 107-3275
 - 3 0.08µm Au PLATING OVER 1.27µm Ni PLATING
 - 4 0.08µm Au PLATING OVER 1.27µm Ni PLATING OVER 0.76µm Cu PLATING
 - 5 0.76µm Au PLATING OVER 1.27µm Ni PLATING OVER 0.76µm Cu PLATING
 - 6 FOR TECHNICAL DATA REFER TO YOUR LOCAL TYCO ELECTRONICS SALES OFFICE
 - 7 ALL DIMENSIONS ARE NOMINAL FOR REFERENCE ONLY UNLESS OTHERWISE STATED

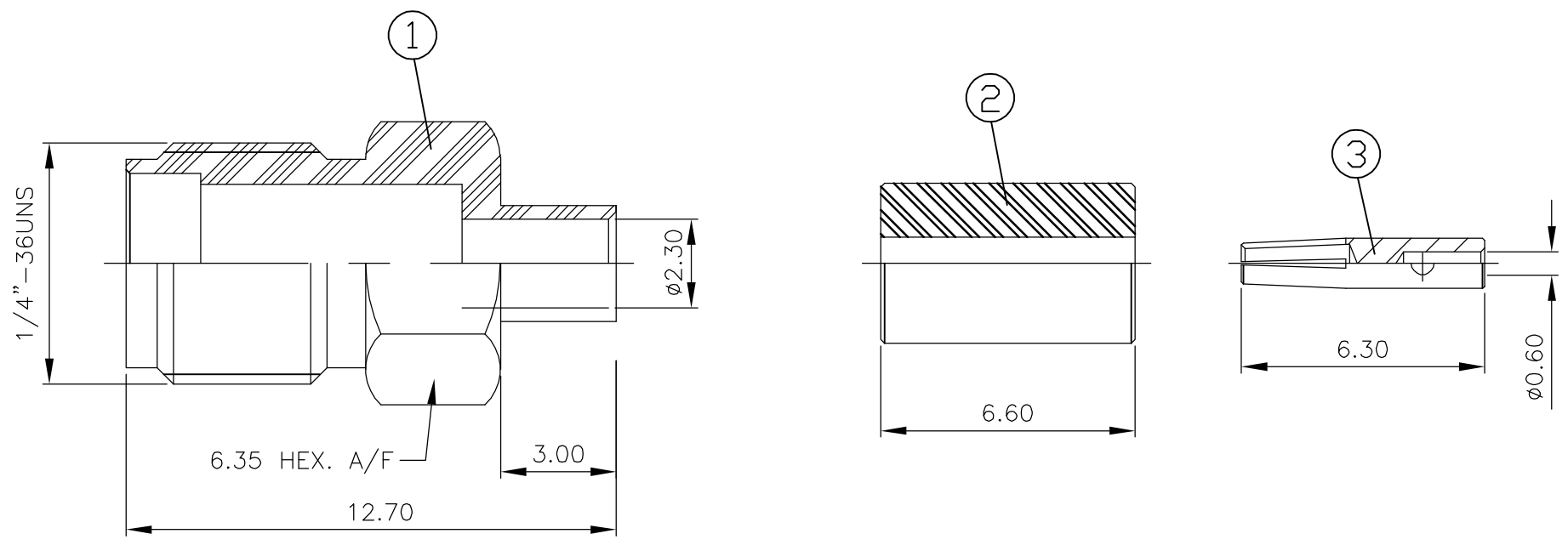

RECOMMENDED
CABLE STRIPPING DIM'S

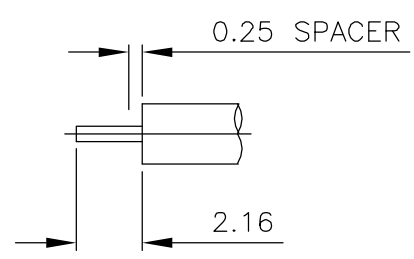

				1	1	1	1	PTFE	INSULATOR	3
				1	1	1	1	BERYLLIUM COPPER 5	SOCKET	2
				1	1	-	-	BRASS 4	BODY	1
				-	-	1	1	STAINLESS STEEL 3	BODY	1
				3--1	3--0	1--1	1--0	MATERIAL	DESCRIPTION	ITEM
				2	1	2	1			
QUANTITY PER ASSY								PARTS LIST		

THIS DRAWING IS A CONTROLLED DOCUMENT.		DWN R.SMITH 30JAN04	Tyco Electronics Corporation Bideford, UK, EX39 4HE		
DIMENSIONS: mm		CHK S.PARLOW 30JAN04			
TOLERANCES UNLESS OTHERWISE SPECIFIED:		APVD F.WHEELER-KING 30JAN04	NAME SMA STRAIGHT JACK DIRECT SOLDER NON CAPTIVE CENTRE CONTACT RG405/U		
0 PLC ± -		PRODUCT SPEC 108-3460	SIZE A3		
1 PLC ± -		APPLICATION SPEC 411-3276	CAGE CODE 00779		
2 PLC ± -		WEIGHT -	DRAWING NO C-1478929		
3 PLC ± -		MATERIAL SEE TABLE	RESTRICTED TO -		
4 PLC ± -			SCALE 1:1		
ANGLES ± -		SHEET 1 OF 1			
FINISH -		REV A			
CUSTOMER DRAWING					

单击下面可查看定价，库存，交付和生命周期等信息

[>>TE Connectivity\(泰科\)](#)