

THIS DRAWING IS UNPUBLISHED. RELEASED FOR PUBLICATION
 © COPYRIGHT - By - ALL RIGHTS RESERVED.

LOC	DIST	REVISIONS					
CM	00	P	LTR	DESCRIPTION	DATE	DWN	APVD
		C		REVISED PER ECR-20-101152	02SEP2021	PJ	VS

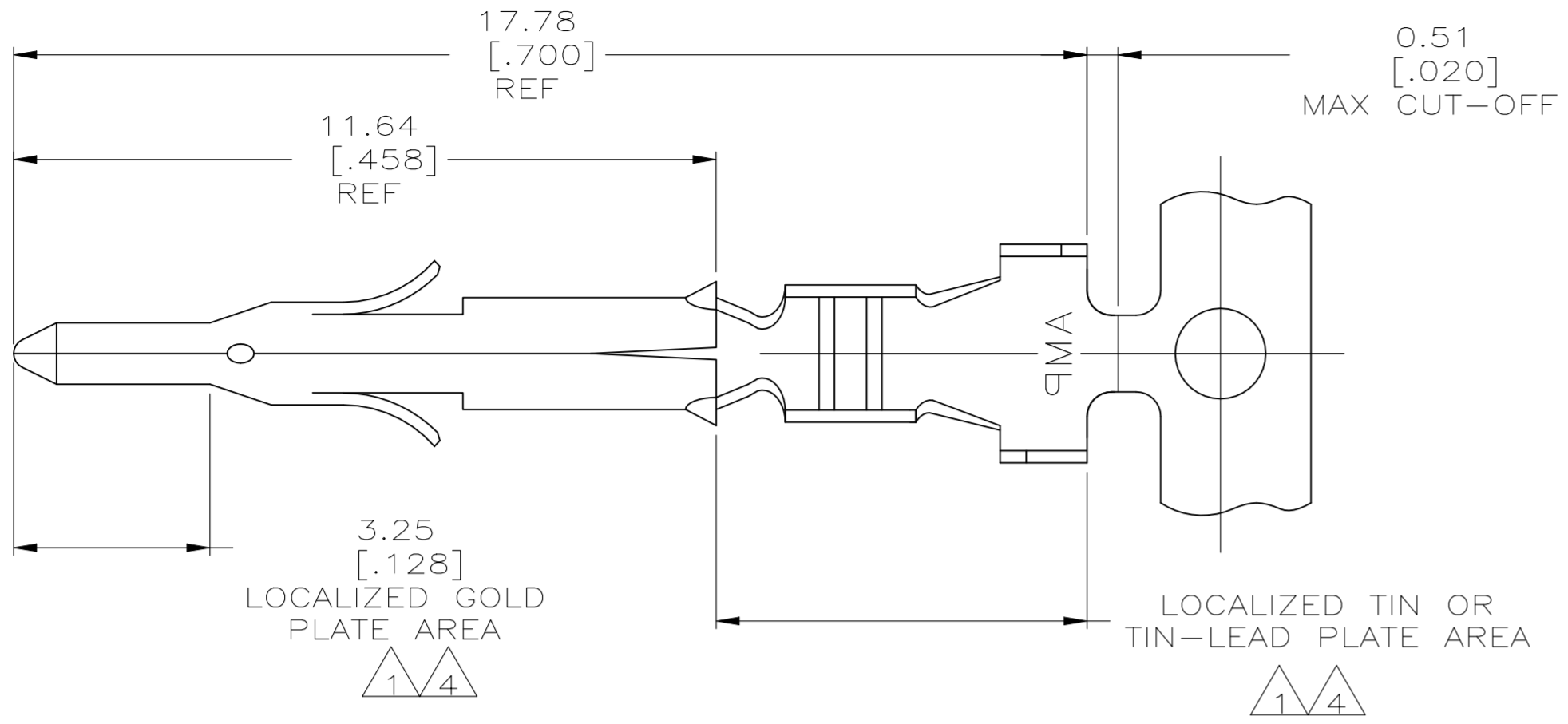

1 0.00076 [.000030] MIN GOLD PER IN LOCALIZED GOLD PLATE AREA AND 0.00254-0.00635 [.000100-.000250] BRIGHT TIN-LEAD PER IN LOCALIZED TIN-LEAD PLATE AREA OVER 0.00127 [.000050] MIN NICKEL.

2. WIRE RANGE: 0.5-1.4MM² (20-16 AWG).
 3. INSULATION RANGE: 2.01-3.20 [.079-.126] DIA.

4 0.00076 [.000030] MIN GOLD PER IN LOCALIZED GOLD PLATE AREA AND 0.00254-0.00635 [.000100-.000250] MATTE TIN IN LOCALIZED TIN PLATE AREA OVER 0.00127 [.000050] MIN NICKEL.

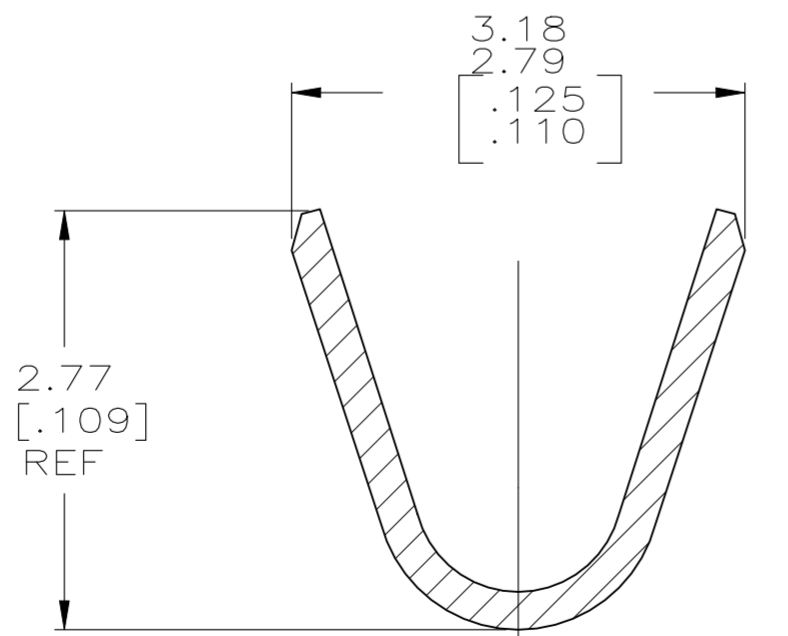
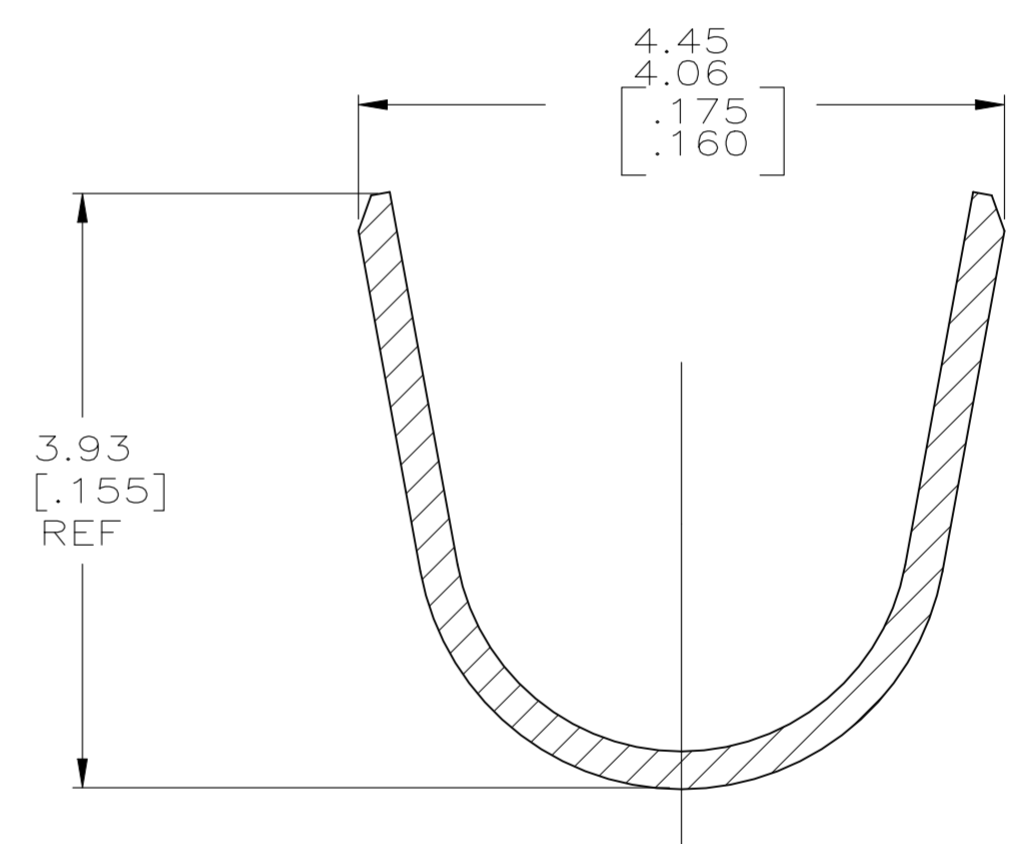
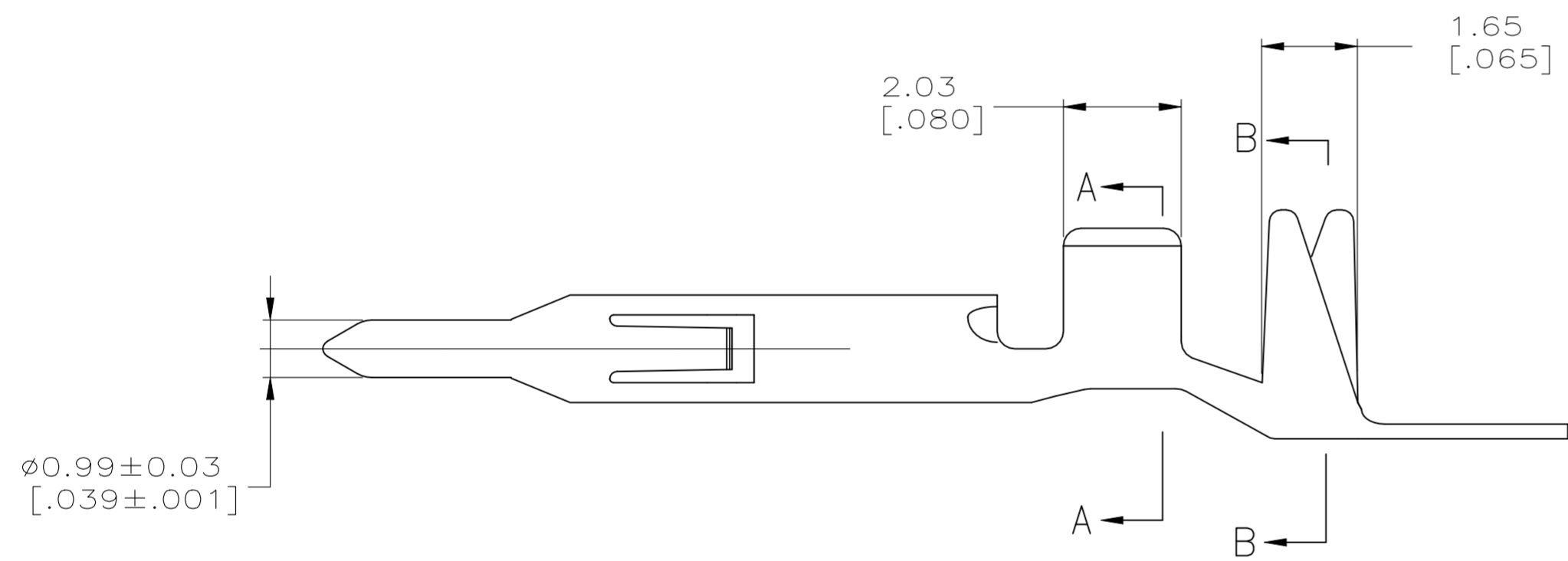

4	0.20 [.008] BRASS	1-794406-0
1	0.25 [.010] BRASS	794406-3
PRE-TIN	0.25 [.010] BRASS	794406-1
FINISH	MATERIAL	PART NUMBER

THIS DRAWING IS A CONTROLLED DOCUMENT.		DWN S. HOOVER 10JAN03	STE TE Connectivity	
DIMENSIONS: mm [INCHES]		CHK C. JONES 10JAN03		
TOLERANCES UNLESS OTHERWISE SPECIFIED:		APVD C. JONES 10JAN03	NAME	
0 PLC ± -	1 PLC ± -	PRODUCT SPEC	PIN, MINI UNIVERSAL MATE-N-LOK(TM)	
2 PLC ± -	3 PLC ± 0.13[.005]	APPLICATION SPEC	SIZE A2	CAGE CODE 00779
4 PLC ± -	ANGLES ± -	WEIGHT -	DRAWING NO C=794406	RESTRICTED TO -
MATERIAL -	FINISH -	CUSTOMER DRAWING	SCALE 10:1	SHEET 1 of 1
			REV C	

单击下面可查看定价，库存，交付和生命周期等信息

[>>TE Connectivity\(泰科\)](#)