

THIS DRAWING IS UNPUBLISHED. RELEASED FOR PUBLICATION
 © COPYRIGHT BY TYCO ELECTRONICS CORPORATION. ALL INTERNATIONAL RIGHTS RESERVED.

LOC	DIST	REVISIONS			
P	LTR	DESCRIPTION	DATE	DWN	APVD
AF	50				
		C4 REVISED PER ECR-08-022956	15SEP08	HMR	GJ

- SPECIFICATIONS
 MAGNET WIRE: #27-#36 AWG,
 0.36-0.13 [.014-.005] mm DIA. COPPER
 LEAD WIRE: 0.8-0.3mm2 [#18-#22] AWG, STRANDED, BONDED, OR
 SOLID WITH PVC INSULATION. MAX INSULATION OUTSIDE DIA
 2.9mm [.115] NO STRIPPING REQUIRED. OTHER INSULATION
 TYPES MAY BE ACCOMMODATED, CONSULT
 TYCO ELECTRONICS FOR APPROVAL.
- POCKET RECOMMENDATION: 1601421.
 ALTERNATE POCKET : #1601462.
- TERMINAL APPLICATION TO COMPLY WITH TYCO ELECTRONICS
 SPECIFICATION 114-13166 FIGURE 3 OR 4.

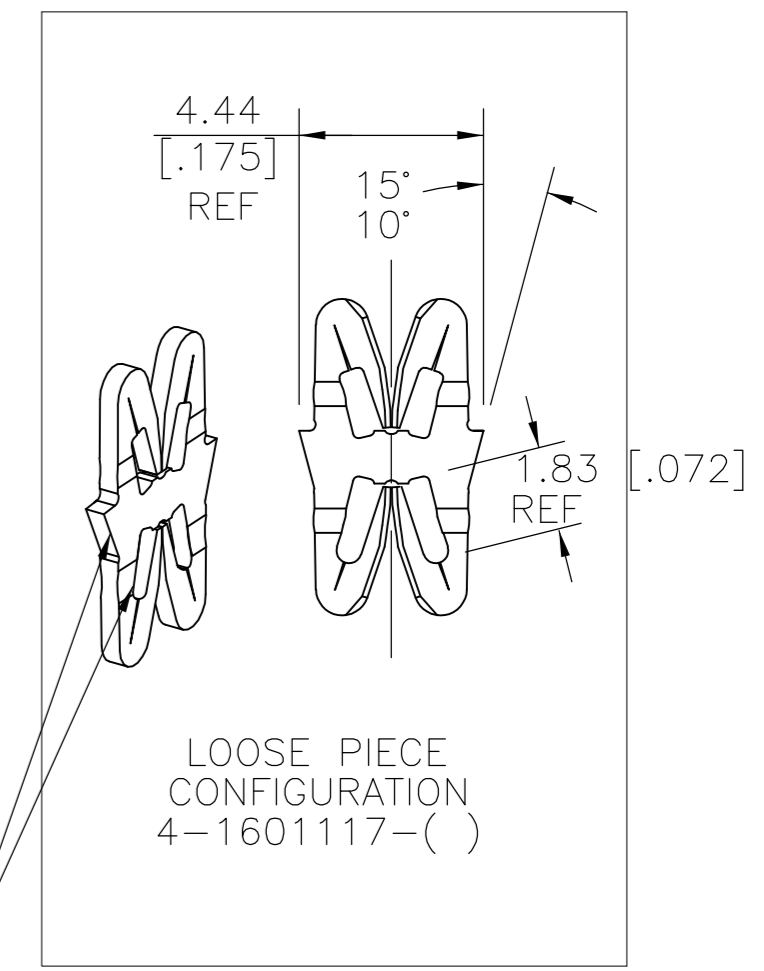
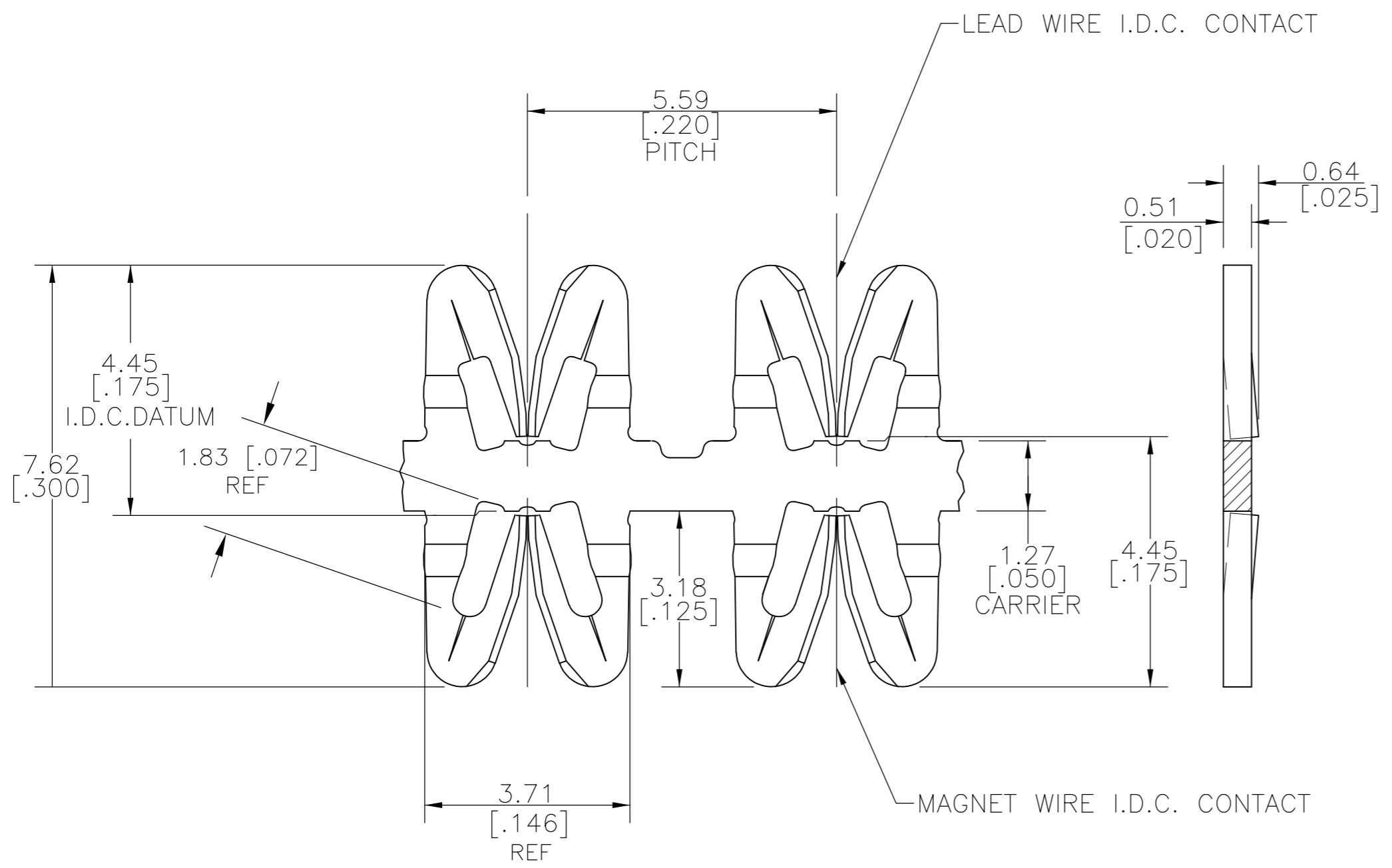

NOTE: BARB
 DIRECTION RELATIVE
 TO WINDOW LENGTH



UNPLATED	-	4-1601117-1
UNPLATED	150-010-000	2-1601117-1
UNPLATED	150-003-000	1601117-1
FINISH	REFERENCE PART NUMBER	PART NUMBER
THIS DRAWING IS A CONTROLLED DOCUMENT.		DWN J.WELLER 11JAN2002
DIMENSIONS: INCHES		CHK M.FEHER 17DEC03
TOLERANCES UNLESS OTHERWISE SPECIFIED:		APVD K.RANDOLPH 11JAN2002
0 PLC ± -	1 PLC ± 0.25 [.01]	NAME
2 PLC ± 0.13 [.005]	3 PLC ± -	PRODUCT SPEC
4 PLC ± -	ANGLES ± 2°	108-2244
MATERIAL BRASS, HOB	FINISH SEE TABLE	APPLICATION SPEC
		WEIGHT -
		CUSTOMER DRAWING
		SIZE A2
		CAGE CODE 00779
		DRAWING NO C=1601117
		RESTRICTED TO -
		SCALE 11:1
		SHEET 1 OF 1
		REV C4

单击下面可查看定价，库存，交付和生命周期等信息

[>>TE Connectivity\(泰科\)](#)