

SPECIFICATION CONTROL DRAWING

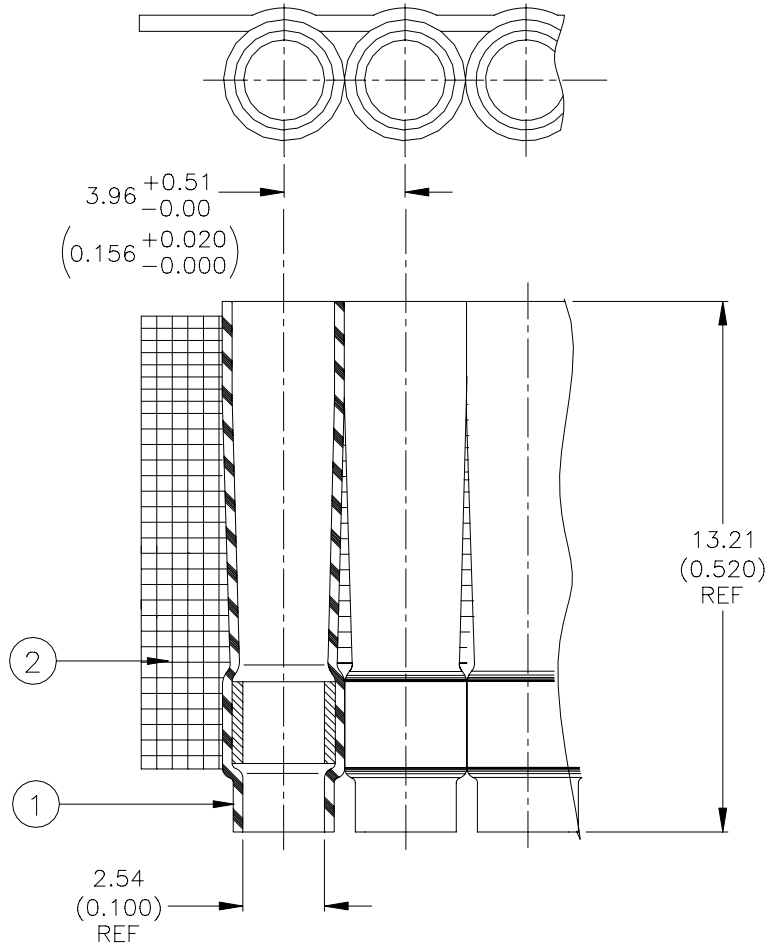

MATERIALS

1. SOLDER SLEEVE WIRE TERMINATOR: D-128-0024, Quantity Per Assembly: 750.
2. CARRIER STRIP: Adhesive Coated High Temperature Tape

APPLICATION

1. This assembly is designed for use in conjunction with a Raychem AS-4000 Wire Organization System on connectors with terminals on 3.96 (0.156) center spacing. For usage parameters, see Raychem Devices Specification Control Drawing D-128-0024.
2. Wire terminators are to be inspected to Raychem Devices Specification Control Drawing D-128-0024.

tyco / Electronics / Raychem <small>307 Constitution Drive Menlo Park, CA 94025, USA</small>		Wire and Harnessing Products	TITLE: 3.96 (0.156) Centers SOLDER PAK ASSEMBLY FOR AS-4000 SLEEVE: D-128-0024				
<small>Unless otherwise specified dimensions are in millimeters. Inches dimensions are in between brackets.</small>			DOCUMENT NO.: D-704-0036				
TOLERANCES: 0.00 N/A 0.0 N/A 0 N/A	ANGLES: N/A ROUGHNESS IN MICRON	Tyco Electronics reserves the right to amend this drawing at any time. Users should evaluate the suitability of the product for their application.	DCR NUMBER: D010014		REPLACES: N/A		
DRAWN BY: M. FORONDA	DATE: 08-Feb.-01	PROD. REV. A	DOC ISSUE: 1	SCALE: None	SIZE: A	SHEET: 1 of 1	

If this document is printed it becomes uncontrolled. Check for the latest revision.

单击下面可查看定价，库存，交付和生命周期等信息

[>>TE Connectivity\(泰科\)](#)