

LOC	DIST	REVISIONS					
		P	LTR	DESCRIPTION	DATE	DWN	APVD
-	-		AI	REVISED PER ECO-10-010249	15MAY2010	HMR	NE

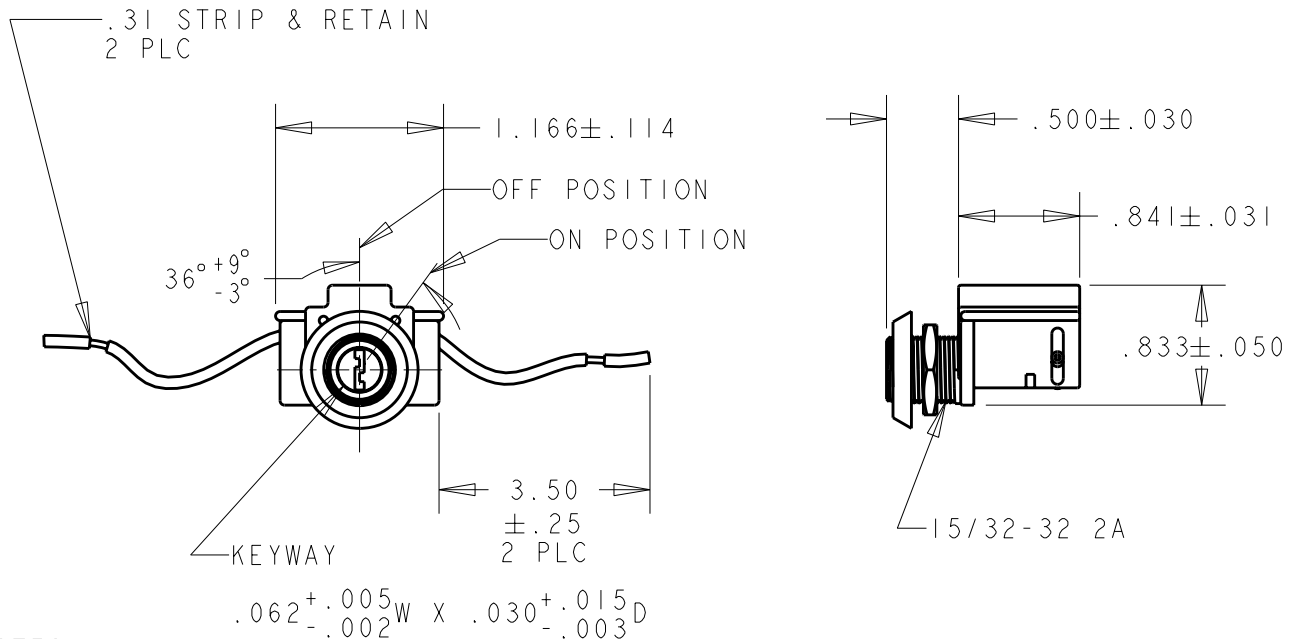

NOTES:

- KEY REMOVABLE BOTH POSITIONS.
- KEYSWITCH SUPPLIED WITH 1 HEX NUT, 1 DRESS NUT AND 1 KEY.
- WIRE: 18 AWG BOND WIRE, TINNED, PVC INSULATED, W/ 80°C AND 300 V RATING (UL 1007).  
CONTACT MATERIAL: MOVABLE-BRONZE, SILVER PLATED;  
STATIONARY-BRASS, SILVER PLATED.  
CIRCUIT: SPST  
ACTION: OFF-ON
- ELECTRICAL SPECIFICATIONS:  
KEYSWITCH RATING: 6A, 125V AC; 3A, 250V AC  
DIELECTRIC VOLTAGE: 1000V RMS MIN.  
INSULATION RESISTANCE: 100 MΩ MIN.  
CONTACT RESISTANCE: 100 mΩ MAX.  
CYCLE LIFE: 6000 OPERATIONS MIN.  
TEMPERATURE RISE: <30°C AT 6000 OPERATIONS
- ENVIRONMENTAL SPECIFICATIONS:  
OPERATING TEMP: -18°C TO 65°C

1571488-1 PART NUMBER

DIMENSIONS: INCHES	DWN J.C. YOSLER	11NOV2003	MATERIAL	-	FINISH	-
	CHK J.C. YOSLER	11NOV2003	Tyco Electronics Harrisburg, PA 17105-3608			
TOLERANCES UNLESS OTHERWISE SPECIFIED:	APVD M. WILBOURN	07NOV2006				
0 PLC ±	PRODUCT SPEC	-	NAME KEYSWITCH SPST			
1 PLC ±.03	APPLICATION SPEC	-				
2 PLC ±.015	WEIGHT	-	SIZE	CAGE CODE	DRAWING NO	RESTRICTED TO
3 PLC ±.010			A4	00779	C-1571488	-
4 PLC ±			CUSTOMER DRAWING			
ANGLES ±1/2			SCALE	3:4	SHEET	1 OF 1
						REV A1

20

RELEASED FOR PUBLICATION

BY TYCO ELECTRONICS CORPORATION. ALL RIGHTS RESERVED.

THIS DRAWING IS UNPUBLISHED. COPYRIGHT 20

单击下面可查看定价，库存，交付和生命周期等信息

[>>TE Connectivity\(泰科\)](#)