

© COPYRIGHT 19 BY AMP INCORPORATED, HARRISBURG, PA.  
ALL INTERNATIONAL RIGHTS RESERVED. AMP INCORPORATED PRODUCTS  
COVERED BY U. S. AND FOREIGN PATENTS AND/OR PATENTS PENDING.

REVISIONS						
P	F	ZONE	LTR	DESCRIPTION	DATE	APPROVED
		01		REVISED 7617 75	10-81	WAP
		02		ADDED NOTE IO 7848 AMS	3-82	EAM
		03		REVISED ECN 7982 LPL	6-82	EAM
A		A		REVISED 8171 M.S.	10-82	EAM
		B		REV. PER ECN AB-0535	db 11-85	EAM
		B1		ADDED NOTE PER ECN AB-1241	db 11-85	EAM
		B2		REV DIM: AB-1594	db 5-86	EAM
		B3		ECN AB-2066 WJ	12-86	EAM
		C		REV PER DF-017	TS 11/88	DM
		D		REV PER ECN DF-6823	WJK 7/29/93	DM
		E		REV 0600-5641-96	TI 9-97	DM
		F		REV 0600-6467-97	TI 10-98	DM
		G		REV PER 0630-0238-00	CT 18-00	DM
		H		REV PER ECO-05-013283	11-05	PY

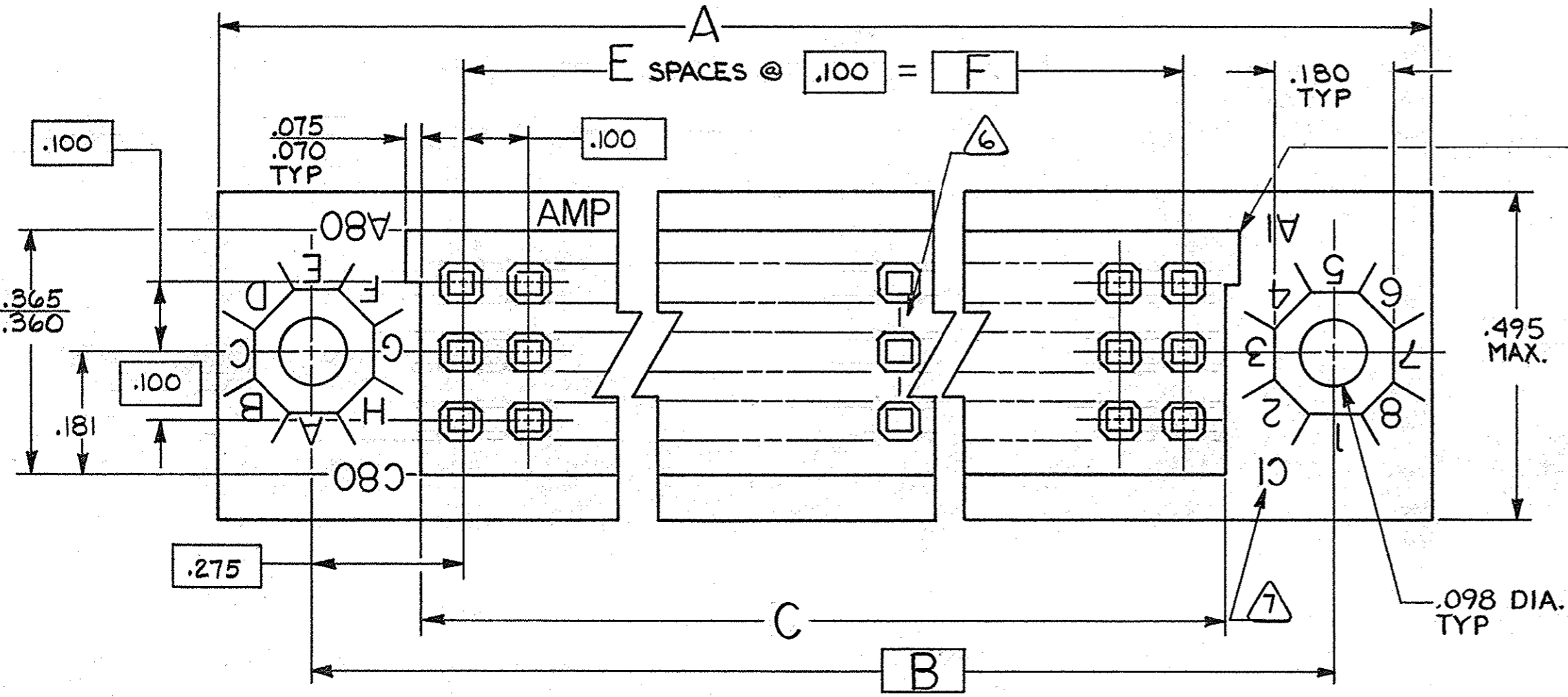

TYPE I AS SHOWN  
SEE DETAIL BELOW  
FOR OTHER TYPES

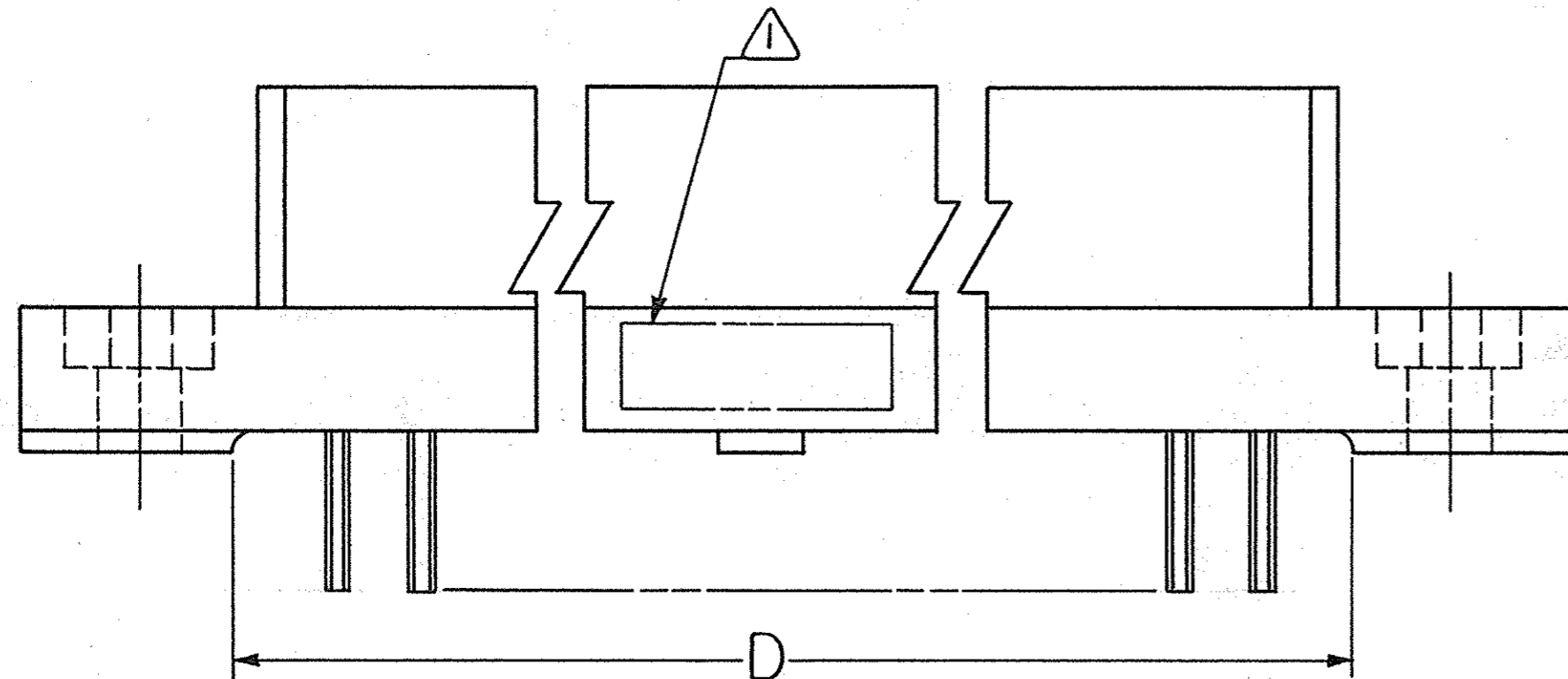

.019 MAX x .014 MAX  
CHANNEL FIT FOR  
.022 MIN DIA. HOLE

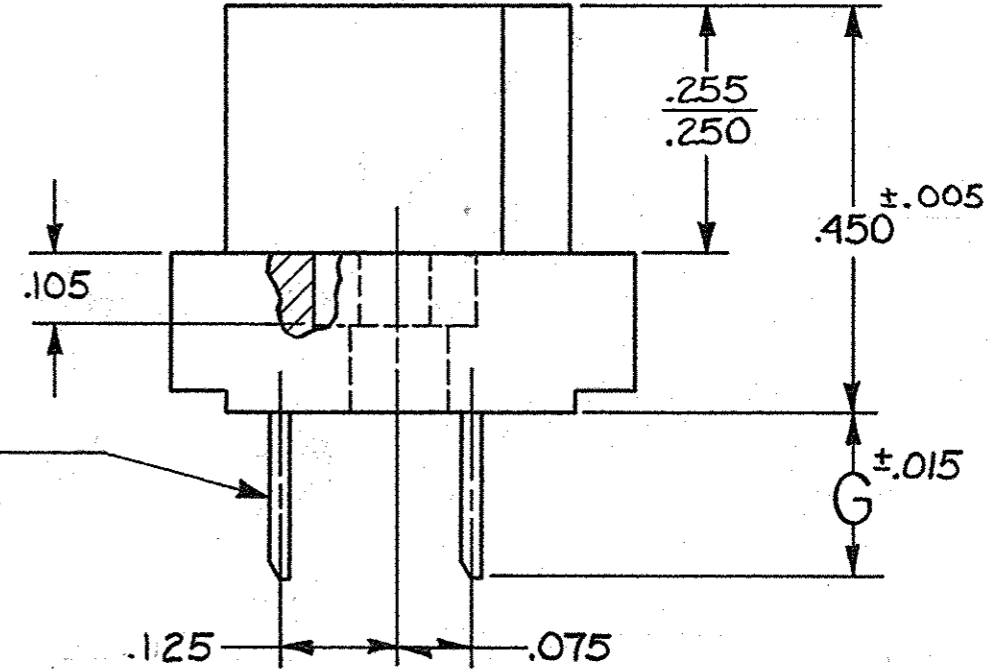

FLOW SOLDER POST  
CONTACT  
(-1, -3, -5, -7)  
2 ROW

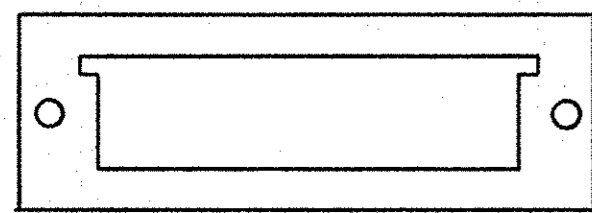

TYPE I

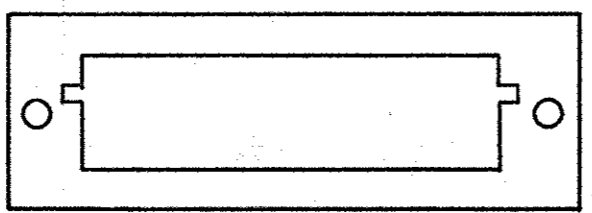

TYPE II

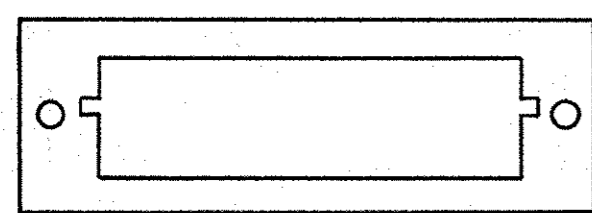

TYPE III

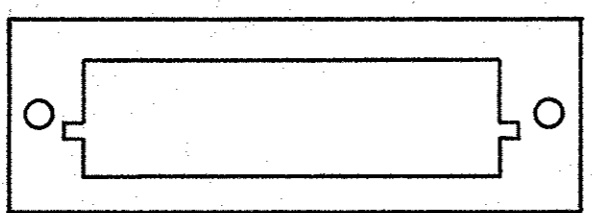

TYPE IV

UNLESS OTHERWISE SPECIFIED DIMENSIONS ARE IN INCHES. TOLERANCES ON: DECIMALS ±.010 ANGLES ±		CONTRACT NO 7-2-80		PART NO	
MATERIAL 2 3		DR Debra Kelly		AMP INCORPORATED Harrisburg, Pa.	
FINISH 4		CHK W. Pritchard Jr 8/15/80		NAME RECEPTACLE ASSEMBLY .100 WITH MOUNTING EARS BOX CONTACT	
		APPD W. Pritchard Jr 8/15/80		SIZE CODE IDENT NO DRAWING NO C 00779 531716	
		APPD E. Parsons 8-15-80		SCALE 5:1 SHEET 1 of 3	
		DSGN APPD			
		OTHER APPD			

531716



© COPYRIGHT 19 BY AMP INCORPORATED, HARRISBURG, PA. ALL INTERNATIONAL RIGHTS RESERVED. AMP INCORPORATED PRODUCTS COVERED BY U. S. AND FOREIGN PATENTS AND/OR PATENTS PENDING.

REVISIONS						
P	F	ZONE	LTR	DESCRIPTION	DATE	APPROVED
			H	SEE SHEET 1		

- ① CUSTOMER PART NO., (94756), AMP, (00779), DATE CODE, PART NO. MARKED THIS AREA.
- ② HOUSING MATERIAL-POLYPHENYLENE SULFIDE, G5T-40F, PER MIL-M-24519.
- ③ CONTACT MATERIAL-BERYLLIUM COPPER OR COPPER-NICKEL-SILICONE
- ④ FINISH-.000050 MIN GOLD OVER .000030 MIN NICKEL
- ⑤ STABILIZERS HAVE NOT BEEN FASTENED TO THE CONNECTOR HOUSING FOR EASY REMOVAL AT LINES INDICATING EVERY FIVE CAVITIES, BEGINNING AT POSITION 1, CUSTOMERS DISCRETION. MARKED THIS SURFACE
- ⑥ LETTERS INDICATING OUTSIDE ROWS AND NUMBERS INDICATING END CAVITIES MARKED THIS SURFACE, .062 HIGH.
- 8. KEYS (2) AND KEY MOUNTING HARDWARE (2) PACKAGED WITH CONNECTOR
- 9. MIL-C-55302 GROUP A & B TESTING REQUIRED

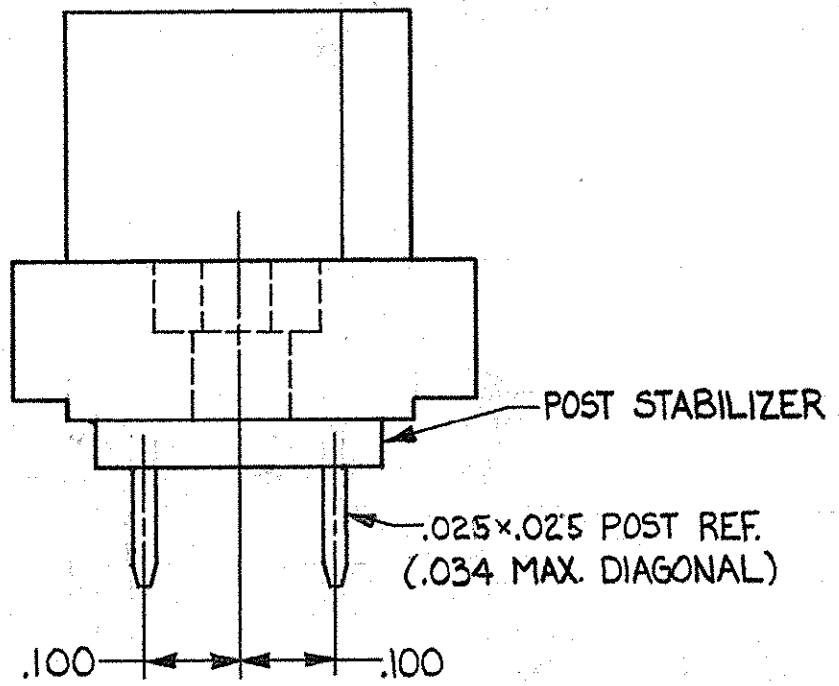

WRAP TYPE POST  
3 HIGH CONTACT  
(-2, -4, -6, -8) ⑤  
2 ROW

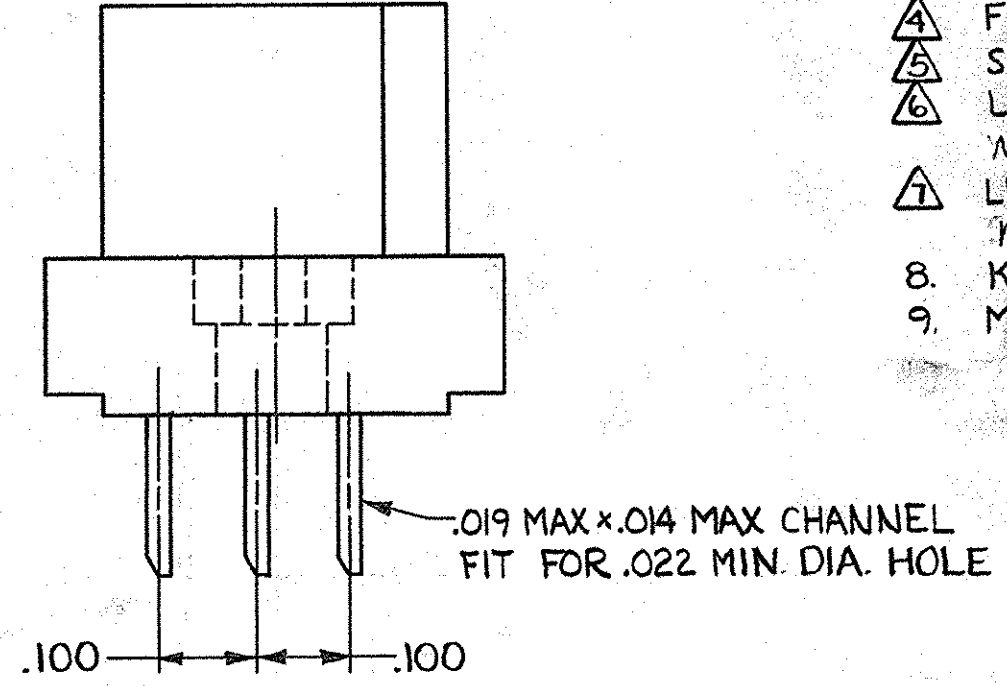

FLOW SOLDER POST  
CONTACT  
(-9, 1--1, 1--3, 1--5)  
3 ROW

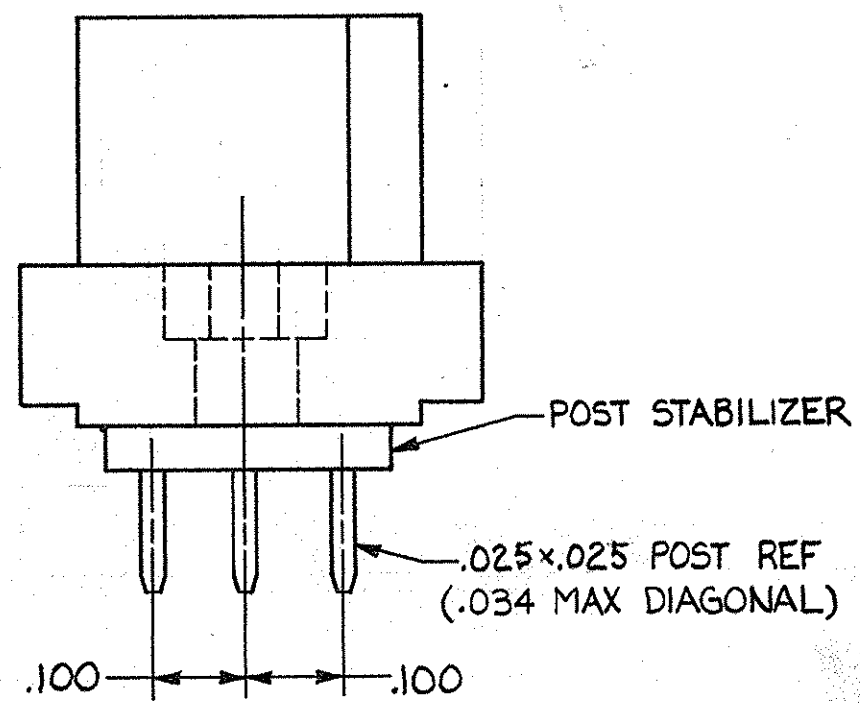

WRAP TYPE POST  
3 HIGH CONTACT ⑤  
(1--0, 1--2, 1--4, 1--6)  
3 ROW

OBS	414-2869-016	240	IV	.675	7.900	79	8.125	8.024	8.450	8.750	240	1-531716-6
OBS	-015		IV	.195								1-5
OBSOLETE	-014		III	.675								1-4
	-013		III	.195								1-3
	-012		II	.675								1-2
	-011		II	.195								1-1
	-010		I	.675								1-0
	-009	240	I	.195								-9
OBSOLETE	-008	160	IV	.675								-8
	-007		IV	.195								-7
	-006		III	.675								-6
	-005		III	.195								-5
	-004		II	.675								-4
	-003		II	.195								-3
OBS	414-2869-001	160	I	.675	7.900	79	8.125	8.024	8.450	8.750	240	531716-1
	CUSTOMER PART NUMBER	NO. OF CONTACTS	TYPE	G	F	E	D	C	B	A	NO. OF POSITIONS	PART NO

UNLESS OTHERWISE SPECIFIED DIMENSIONS ARE IN INCHES. TOLERANCES ON: DECIMALS ±.010 ANGLES	CONTRACT NO	AMP INCORPORATED Harrisburg, Pa.	
	MATERIAL	DR Debra Kelly 7-2-80	NAME RECEPTACLE ASSEMBLY, .100" WITH MOUNTING EARS, BOX CONTACT
	FINISH	CHK W.B.ritchard Jr 8/15/80	
		APPD W.B.ritchard Jr 8/15/80	
	APPD E. Parsons 8-15-80	SIZE CODE IDENT NO DRAWING NO C 00779 531716	
	OTHER APPD	SCALE 5:1 SHEET 2 of 3	

THIS DRAWING IS UNPUBLISHED. RELEASED FOR PUBLICATION, 19  
© COPYRIGHT 19 BY AMP INCORPORATED, HARRISBURG, PA. ALL INTERNATIONAL RIGHTS RESERVED. AMP PRODUCTS MAY BE COVERED BY U.S. AND FOREIGN PATENTS AND/OR PATENTS PENDING.

REVISIONS				DATE	APPROVED
P	F	ZONE	LTR		
					H SEE SHEET 1

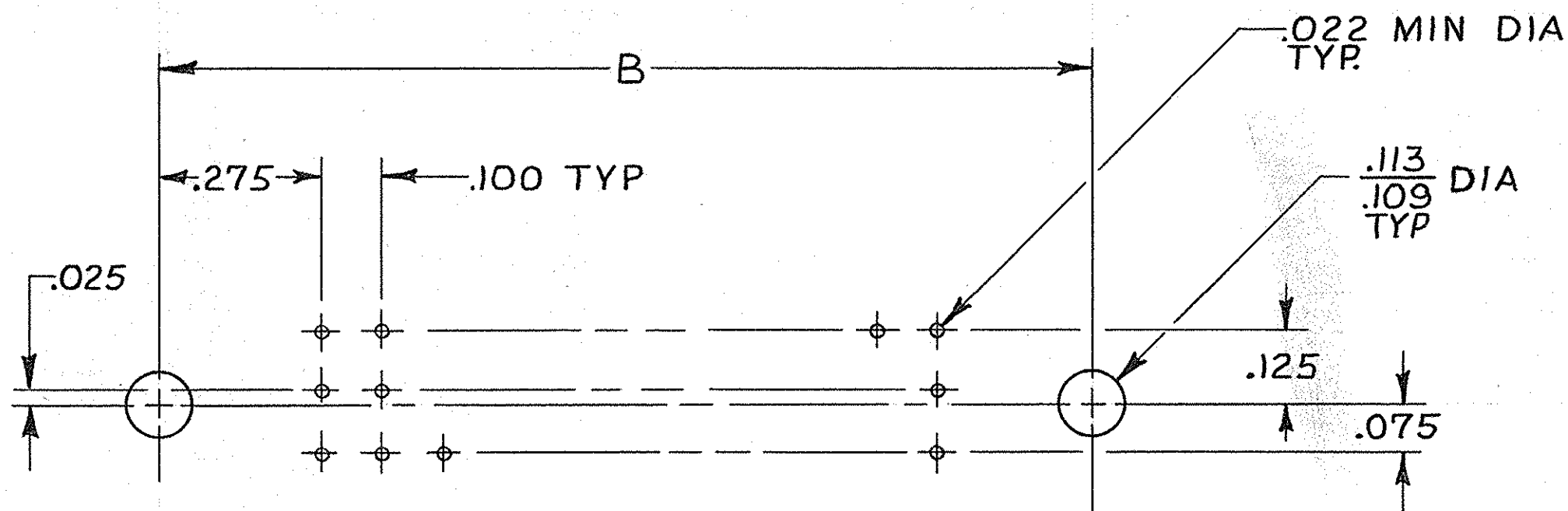

PC BOARD LAYOUT (FLOW SOLDER TYPE)

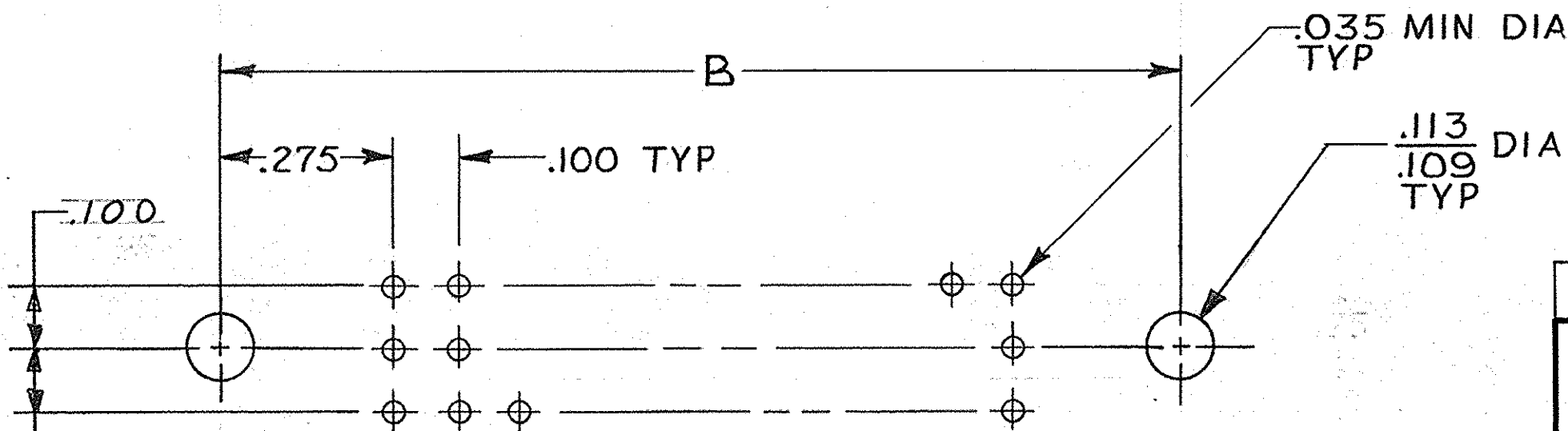

PC BOARD LAYOUT (WIRE WRAP TYPE)

UNLESS OTHERWISE SPECIFIED DIMENSIONS ARE IN INCHES. TOLERANCES ON: DECIMALS ±.010 ANGLES ±		CONTRACT NO	AMP   AMP INCORPORATED Harrisburg, Pa. 17105	
MATERIAL	FINISH	DR <i>W. Steiner</i> 6-22-82	NAME RECEPTACLE ASSEMBLY, .100 $\phi$ , W/MOUNTING EARS, BOX CONTACT	
		CHK <i>E.A.M.</i>	SIZE <b>C</b>	FSCM NO <b>00779</b>
		APPD <i>E.D. McLaughlin</i> 10-7-82	DRAWING NO <b>531716</b>	
		APPD <i>E.T. Parsons</i> 10-7-82	SCALE 4:1	SHEET 3 of 3
		DSGN APPD	PART NO	
		OTHER APPD		

531716

单击下面可查看定价，库存，交付和生命周期等信息

[>>TE Connectivity\(泰科\)](#)