

LOC	DIST	REVISIONS					
		P	LTR	DESCRIPTION	DATE	DWN	APVD
		B2		ADDED DASH 3	28 MAY 2008	H. Y.	G. T.
		B3		DASH VERSION 4 ADDED AS PRELIMINARY	02 DEC 2009	PKS	RRP
		B4		293010-4 RELEASED	10MAR2011	PKS	MP
		C		ECR-16-000014	18JAN2016	KD	RR

POLARIZATION KEYS SCHEME

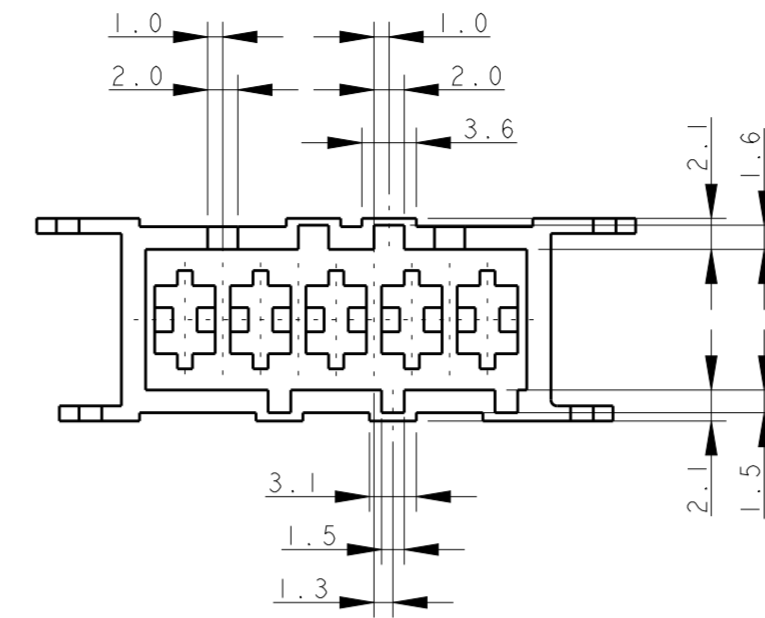

PANEL MOUNT DIMENSIONS
SCALE 1:1

SECTION D-D

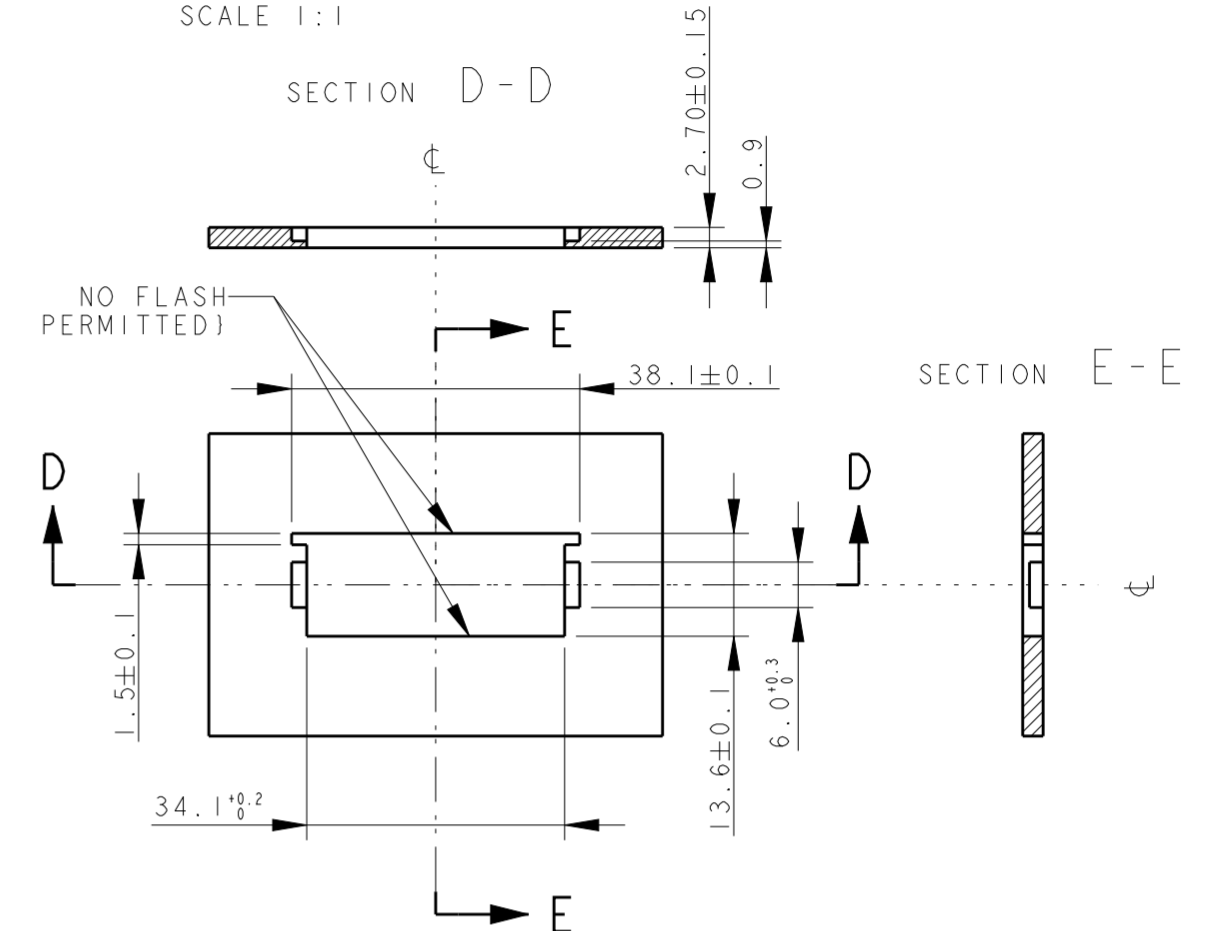

1 TYPICAL CAVITY SUITABLE FOR:
 FASTIN-FASTON TAB CONTACTS 6.3 mm SRS:
 P/N: 60294, 0.3-0.8 mm² WIRE RANGE
 160691, 0.3-0.8 mm² WIRE RANGE
 AMPLIVAR CONTACTS:
 P/N: 141051, 0.1-0.5 mm² WIRE RANGE
 142411, 0.3-1.6 mm² WIRE RANGE
 MAX. INSULATION DIA. 2.8 mm,
 MAX. INSULATION CRIMP WIDTH 3.3 mm.

- 2 PA6 UNFILLED, UL 94-V2, NATURE COLOUR ACCORDING TO IEC-60335-1 NORM.
- 3 PA66 UNFILLED, UL 94-V2, NATURE COLOUR
- 4 TE TRADEMARK "LOGO" AND TE ELECTRONICS "PART NUMBER" OPTIONAL POSITION.
- 5 CIRCUIT IDENTIFICATION NUMBERS, 1 TO 5
- 6 POLARIZATION KEYS DIMENSIONS AND POSITIONS ARE ACCORDING TO "RAST 5" NORM RAST CODE 05-B, 05-D
- 7 PA66 UNFILLED, UL94-V0, NATURAL COLOR
- 8 PA66 UNFILLED, UL94 V0 GW, NATURAL

NATURALE (NATUR)	VEDI NOTA 8 (SEE NOTE 8)	293010-4	C
NATURALE (NATUR)	VEDI NOTA 7 (SEE NOTE 7)	293010-3	C
NATURALE (NATUR)	VEDI NOTA 3 (SEE NOTE 3)	293010-2	C
NATURALE (NATUR)	VEDI NOTA 2 (SEE NOTE 2)	293010-1	C
COLORE (COLORE)	MATERIALE (MATERIALE)	NUMERO (TE P/N)	REV

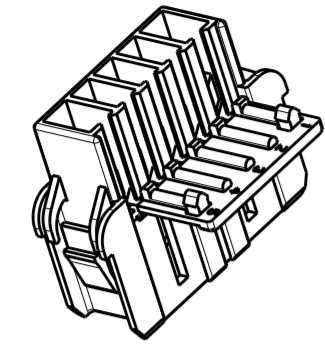

SCALE 1:1

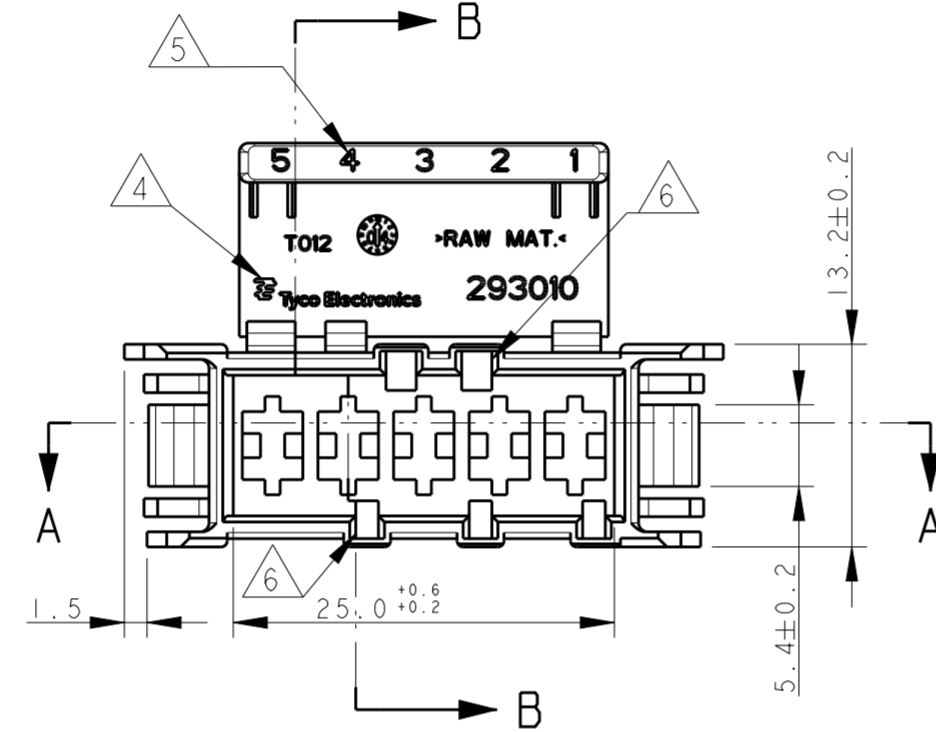
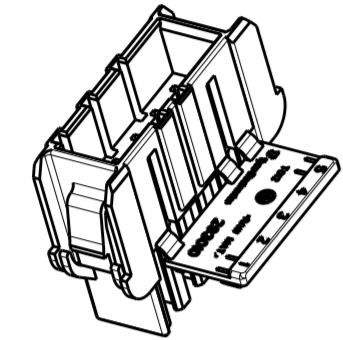

SECTION B-B

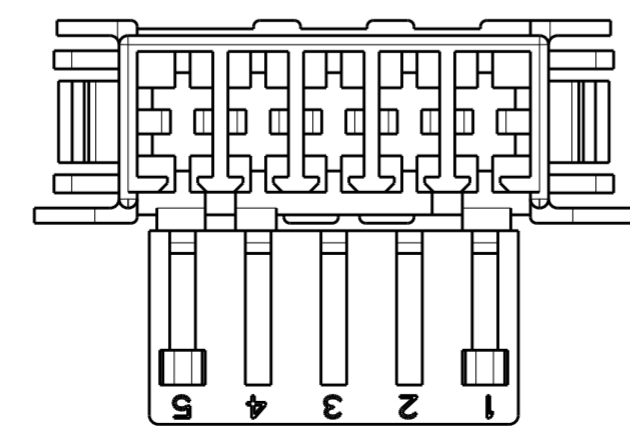
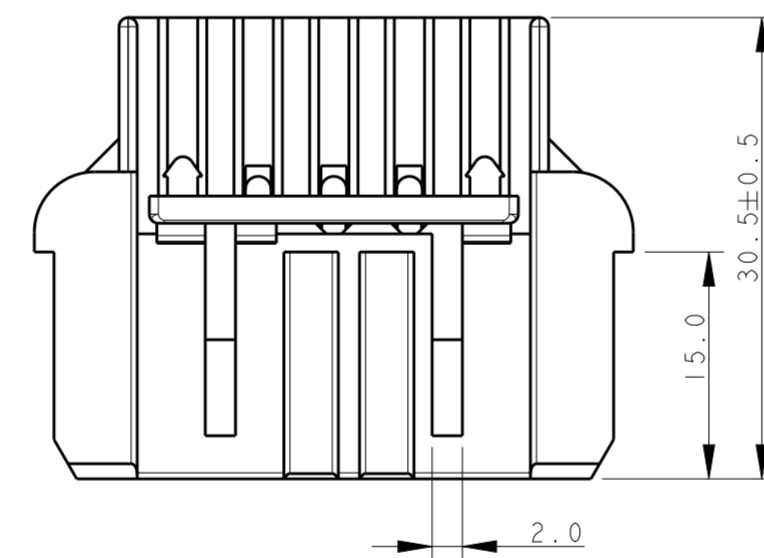
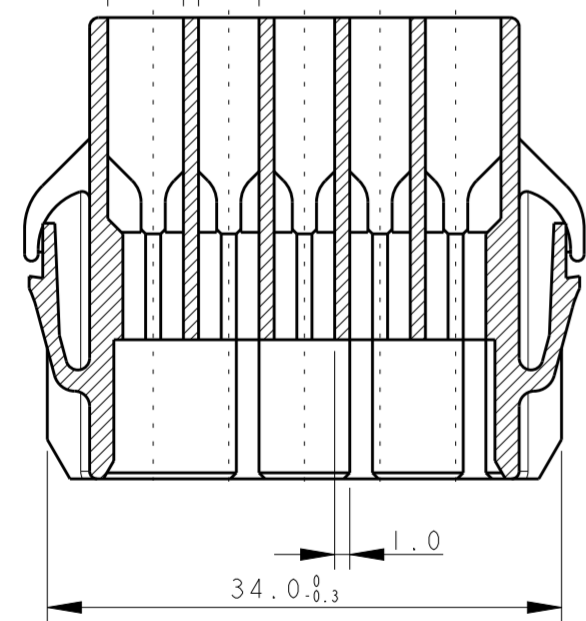
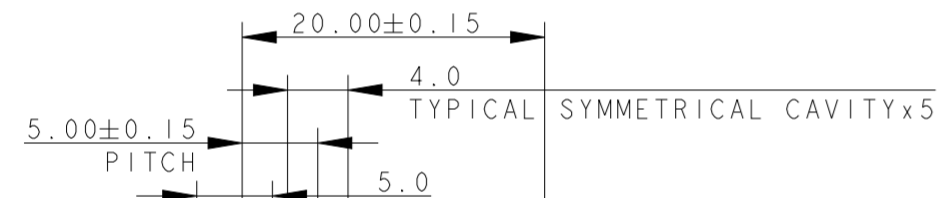
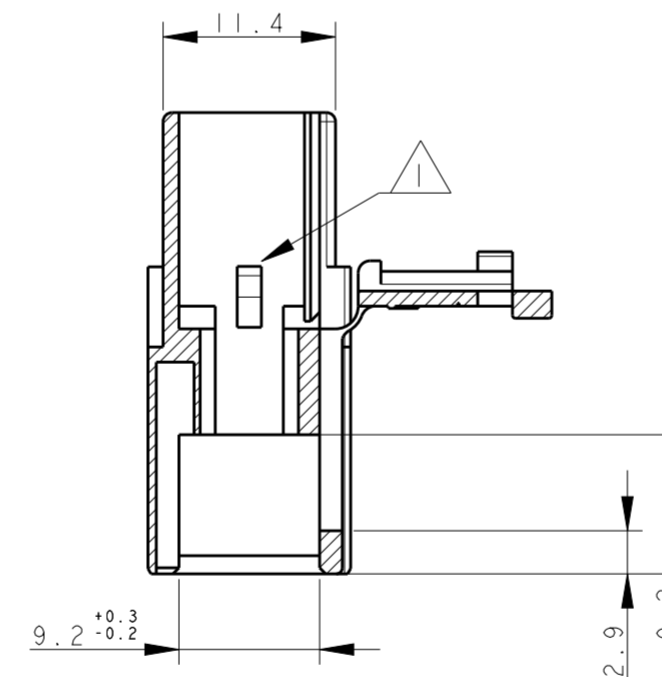

THIS DRAWING IS A CONTROLLED DOCUMENT FOR TYCO ELECTRONICS CORPORATION IT IS SUBJECT TO CHANGE AND THE CONTROLLING ENGINEERING ORGANIZATION SHOULD BE CONTACTED FOR THE LATEST REVISION.

DIMENSIONS: mm	TOLERANCES UNLESS OTHERWISE SPECIFIED:	DWN H. YAALI 11FEB2004	CHK C. TARTARI	APVD	NAME
0 PLC ±	1 PLC ±0.3	PRODUCT SPEC	108-20256	APPLICATION SPEC	5 POS. FASTIN-FASTON Connector TAB HOUSING, RAST 5 08-1.0 MM THK. PANEL MOUNT VERSION
2 PLC ±	3 PLC ±	WEIGHT	A2	00779	CAGE CODE 00779
4 PLC ±	ANGLES ±1°	CUSTOMER DRAWING	SCALE 2:1	SHEET 1 OF 1	REV C
MATERIAL SEE TABLE	FINISH SEE TABLE	Tyco Electronics AMP Italia S.p.A. C.so F. Cervi, 15 COLLEGGIO (TO)			

单击下面可查看定价，库存，交付和生命周期等信息

[>>TE Connectivity\(泰科\)](#)