

THIS DRAWING IS UNPUBLISHED. RELEASED FOR PUBLICATION
 © COPYRIGHT BY TYCO ELECTRONICS CORPORATION. ALL RIGHTS RESERVED.

| LOC | DIST | REVISIONS | | | |
|-----|------|-------------|-------------------------|-----------|--------|
| P | LTR | DESCRIPTION | DATE | DWN | APVD |
| AJ | 16 | 0 | REV PER EC-0S14-0496-04 | 03FEB2005 | AF JGH |

- ① FOR USE WITH BRAID CRIMP HAND TOOL 220190-1.
- ② FOR USE WITH CONTACT CRIMP MIL-C-22520/5-01 (DANIELS AFM 8) TOOL W/ DANIELS POSITIONER K727.
- ③ USE WITH BRAID CRIMP HAND TOOL MIL-C-22520/5-01.
- 4. SEE INSTRUCTION SHEET 408-2987-3.

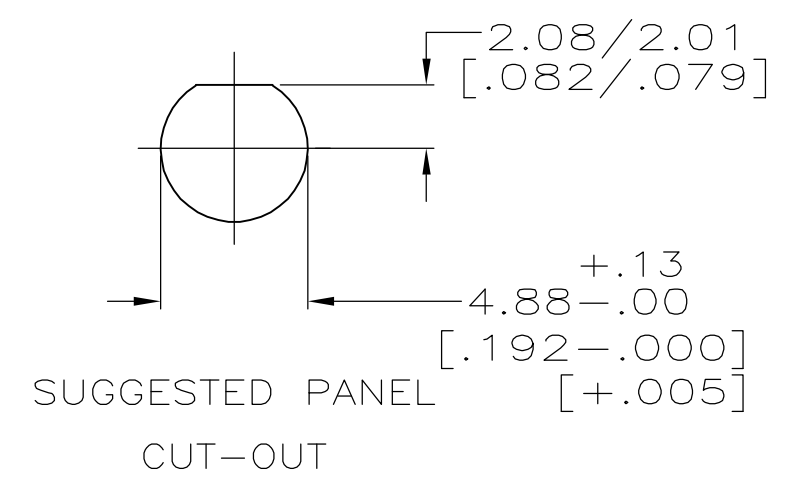
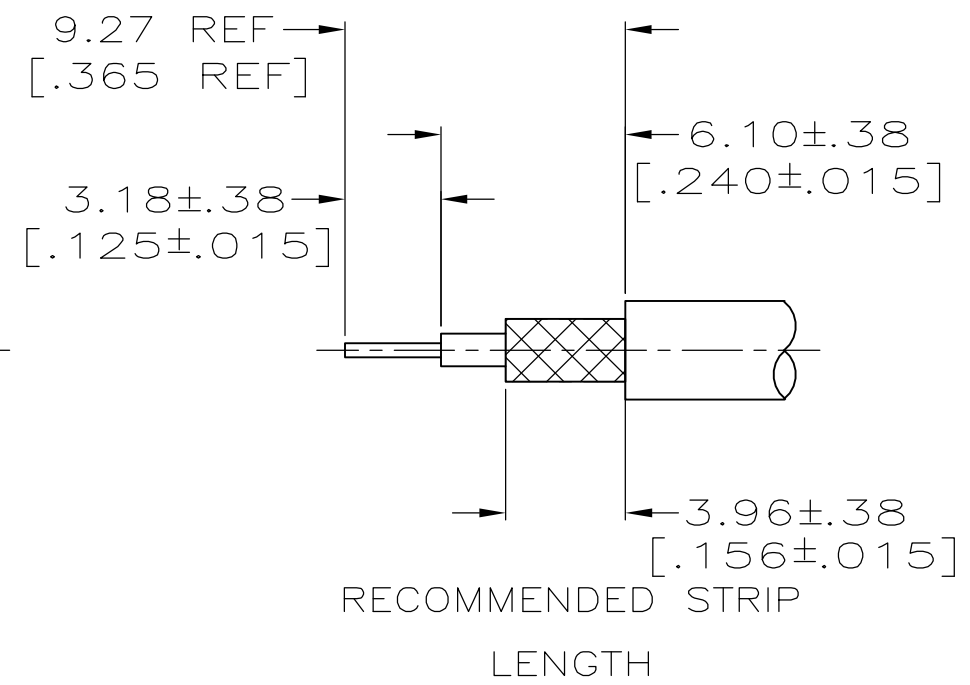
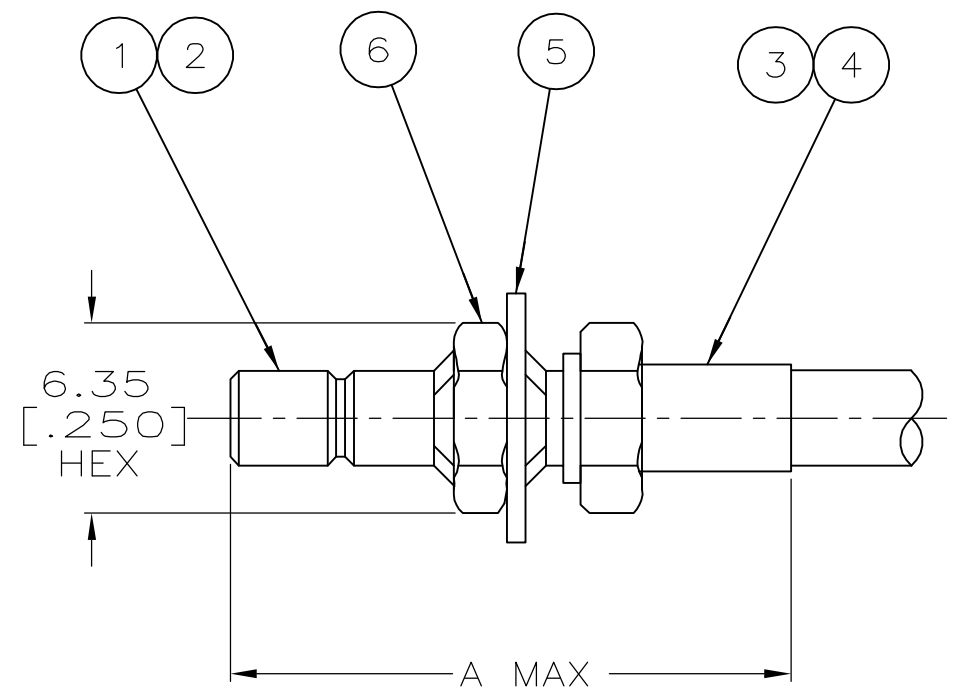

| | | | | | | | | | | | |
|-------------------------|-------|--------|-------------------|-----------|------------------|-------------------|-----------------------|--------------------|--------------------|--------------------------|-------------|
| RG-174/U, 188/U & 316/U | 23.36 | [.920] | Y444 | POSN 2 | 58046-1 (AREA A) | 414969-2 | 415001-2 | 9-228202-0 | 228225-2 | 228222-1 | 5228217-1 |
| FOR USE WITH CABLE | A | | DANIELS DIE SET ③ | DIE SET ② | AMP DIE SET ① | ⑥ JAMNUT QTY=1 | ⑤ LOCKWASHER QTY=1 | ③ FERRULE QTY=1 | ② CONTACT QTY=1 | ① JACK ASSEMBLY QTY=1 | PART NUMBER |

THIS DRAWING IS A CONTROLLED DOCUMENT.

| | | | | | | | | | | | | | | | | |
|--|--|--|---|-------|-----|-------|-----|-------|-----|-------|-----|--------|-----|--|--------|---|
| DIMENSIONS: INCHES | TOLERANCES UNLESS OTHERWISE SPECIFIED: | DWN A. FERNANDEZ-DOCK5 03FEB2005 | Tyco Electronics Corporation Harrisburg, PA 17105-3608 | | | | | | | | | | | | | |
| <table border="1"> <tr><td>0 PLC</td><td>± -</td></tr> <tr><td>1 PLC</td><td>± -</td></tr> <tr><td>2 PLC</td><td>± -</td></tr> <tr><td>3 PLC</td><td>± -</td></tr> <tr><td>4 PLC</td><td>± -</td></tr> <tr><td>ANGLES</td><td>± -</td></tr> </table> | 0 PLC | ± - | | 1 PLC | ± - | 2 PLC | ± - | 3 PLC | ± - | 4 PLC | ± - | ANGLES | ± - | <table border="1"> <tr><td>FINISH</td><td>-</td></tr> </table> | FINISH | - |
| 0 PLC | ± - | | | | | | | | | | | | | | | |
| 1 PLC | ± - | | | | | | | | | | | | | | | |
| 2 PLC | ± - | | | | | | | | | | | | | | | |
| 3 PLC | ± - | | | | | | | | | | | | | | | |
| 4 PLC | ± - | | | | | | | | | | | | | | | |
| ANGLES | ± - | | | | | | | | | | | | | | | |
| FINISH | - | | | | | | | | | | | | | | | |
| MATERIAL | | APVD J. HAVENER 03FEB2005 | NAME JACK, BULKHEAD, SERIES SMB | | | | | | | | | | | | | |
| | | PRODUCT SPEC | | | | | | | | | | | | | | |
| | | APPLICATION SPEC | | | | | | | | | | | | | | |
| | | WEIGHT | SIZE A3 | | | | | | | | | | | | | |
| | | | CAGE CODE 00779 | | | | | | | | | | | | | |
| | | | DRAWING NO C-5228217 | | | | | | | | | | | | | |
| | | | RESTRICTED TO | | | | | | | | | | | | | |
| | | | SCALE 4:1 | | | | | | | | | | | | | |
| | | | SHEET 1 OF 1 | | | | | | | | | | | | | |
| | | | REV 0 | | | | | | | | | | | | | |

CUSTOMER DRAWING

单击下面可查看定价，库存，交付和生命周期等信息

[>>TE Connectivity\(泰科\)](#)