

LOC	DIST	REVISIONS					
GP	00	P	LTN	DESCRIPTION	DATE	DWN	APVD
		A		RELEASED PER ECO-12-013192	04SEP2012	BMM	MRS

- 1 MATERIAL:
CAGE ASSEMBLY: 0.25mm THICK NICKEL SILVER ALLOY
GASKET RETENTION PLATE: STAINLESS STEEL
EMI GASKET: PLATED FILLED SILICONE
- 2 DATUM AND BASIC DIMENSIONS ESTABLISHED BY CUSTOMER.
- 3. MATES WITH SFP MSA COMPLIANT RECEIVERS.
- 4 PADS AND VIAS CHASSIS GROUND.
- 5. INTERPRETATION OF DATUM REFERENCE FRAME IN ACCORDANCE WITH SECT 4.4.1.1 OR ASME Y14.5M-1994.
- 6 MINIMUM PC BOARD THICKNESS:
SINGLE SIDED: 1.5mm
- 7 HOLE PATTERN REPEATS FOR EACH PORT, SPACING BETWEEN PORTS IS 14.25mm.
- 8 REFERENCE APPLICATION SPEC. 114-13120, HOLE A, FOR RECOMMENDED DRILL HOLE DIAMETER AND PLATING THICKNESS.
- 9 REFERENCE APPLICATION SPEC. 114-13120, HOLE B, FOR RECOMMENDED DRILL HOLE DIAMETER AND PLATING THICKNESS.
- 10. CERTAIN MATING TRANCEIVERS MAY REQUIRE ADDITIONAL PCB THICKNESS THAT WOULD NEED TO BE DETERMINED BY THE CUSTOMER.

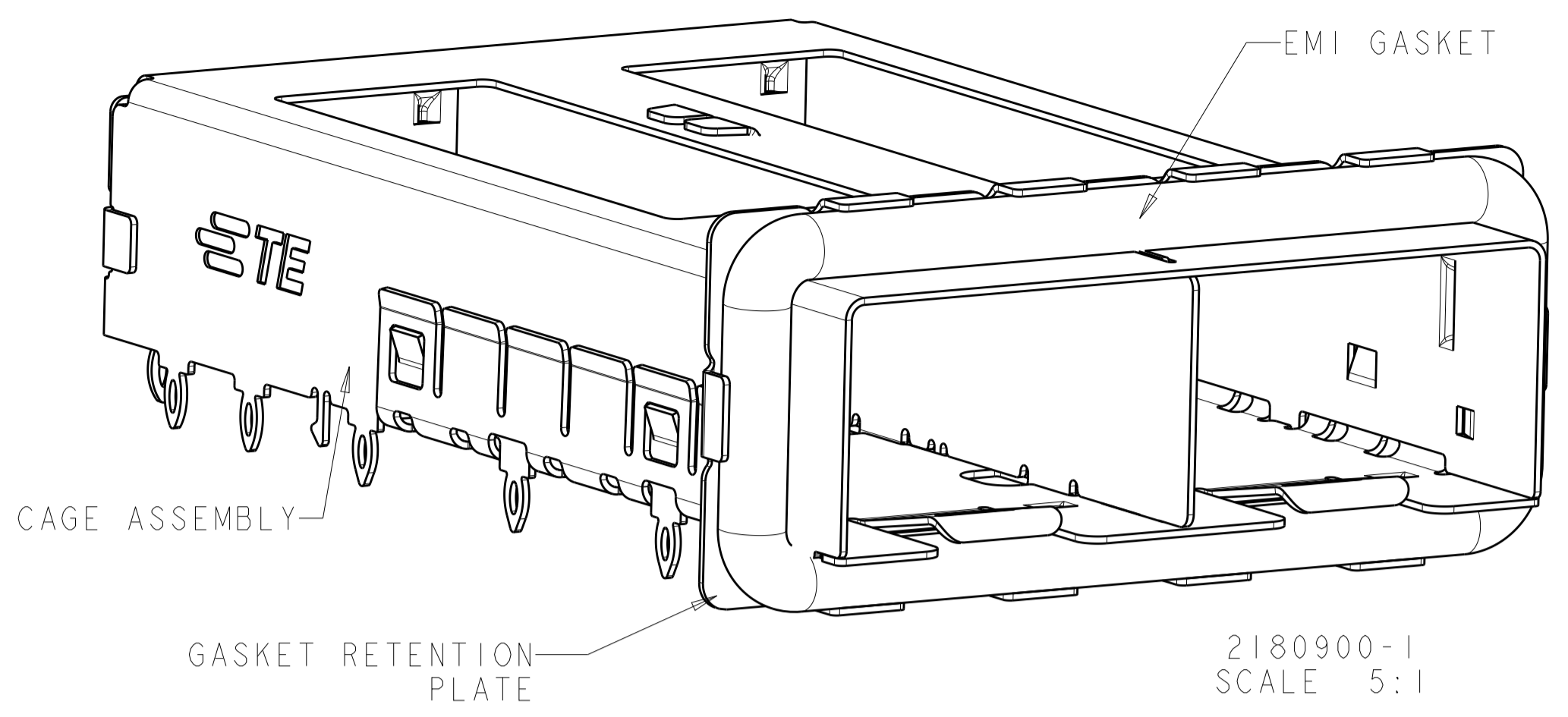

2180900-1
SCALE 5:1

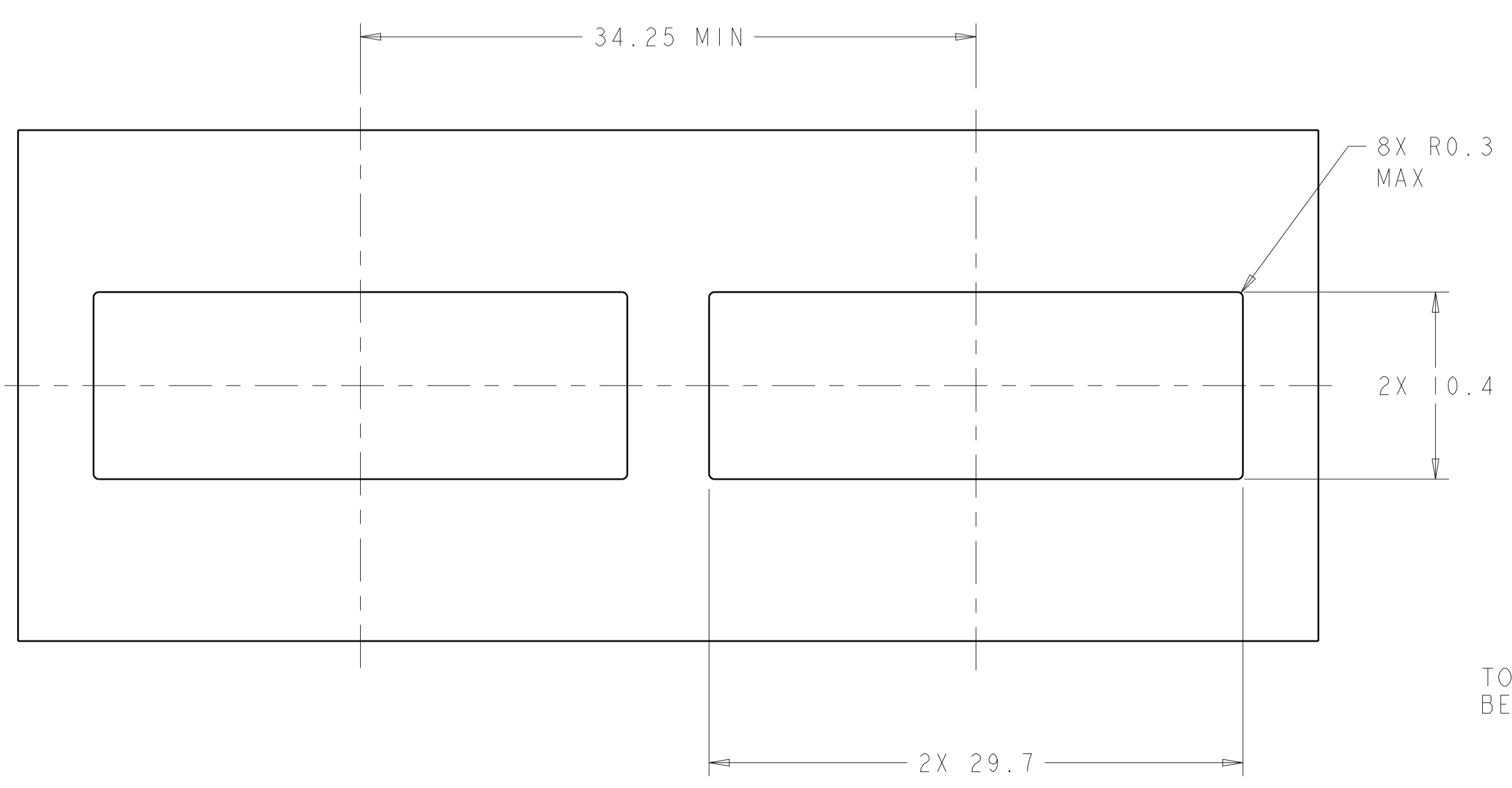
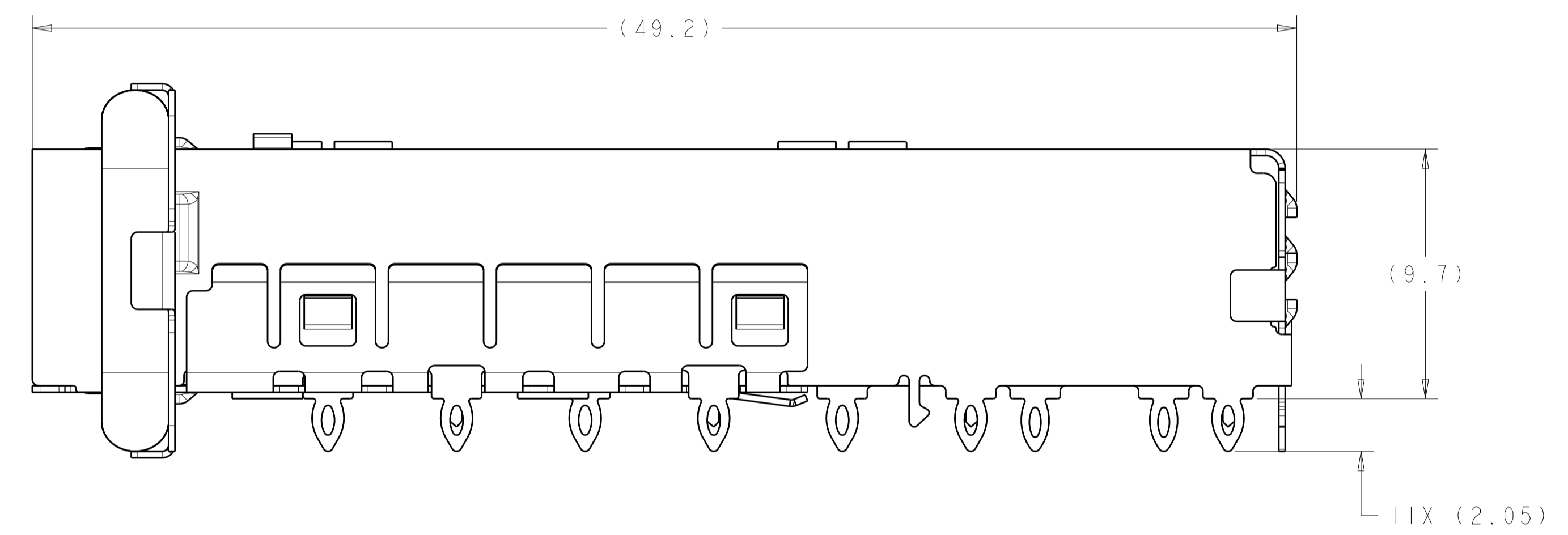
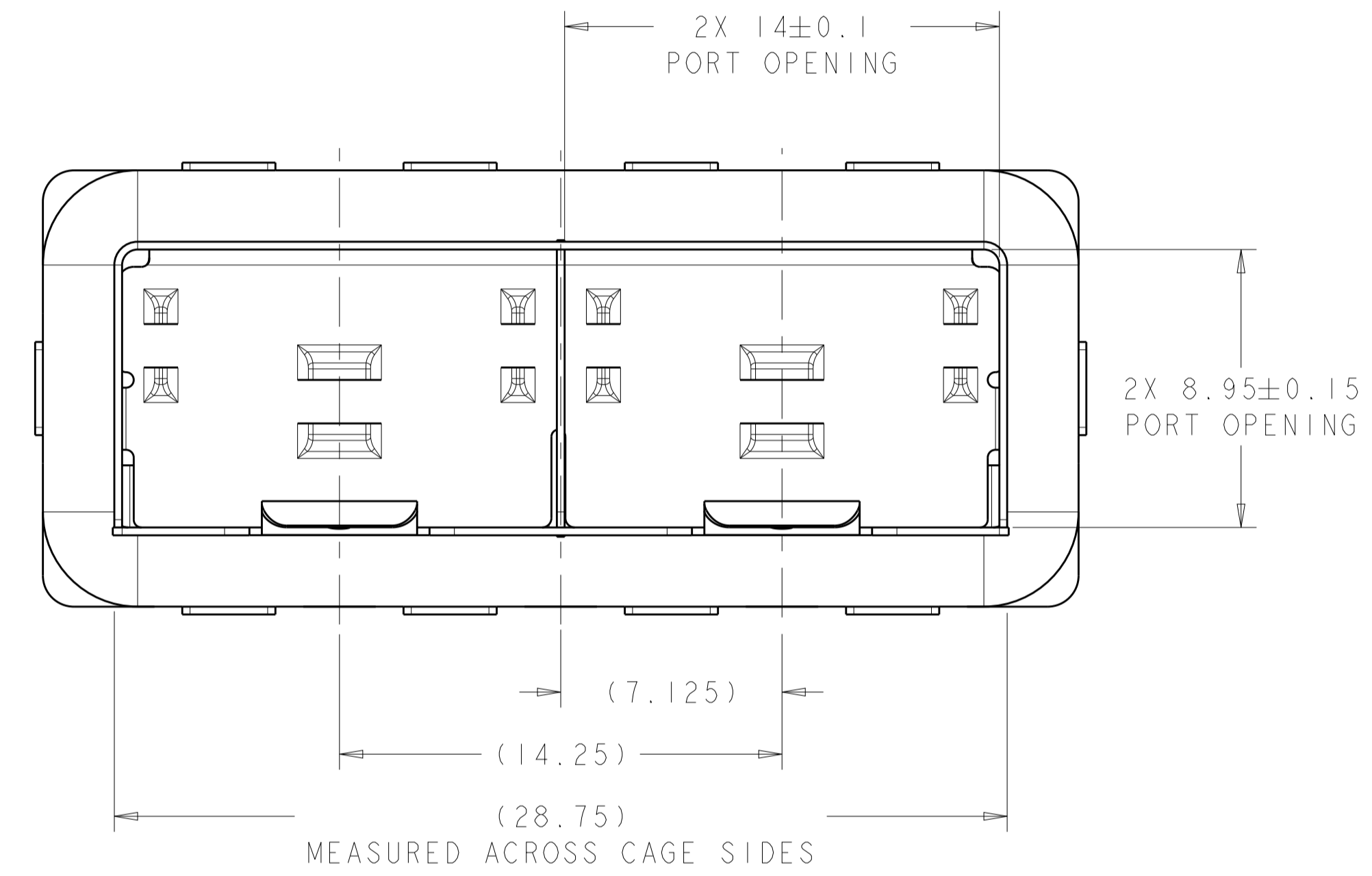

RECOMMENDED BEZEL CUT-OUT
SINGLE SIDED APPLICATIONS
SCALE 4:1

0.23^{+0.10}
-0.14
TOP OF PCB
TO INSIDE OF
BEZEL CUTOUT

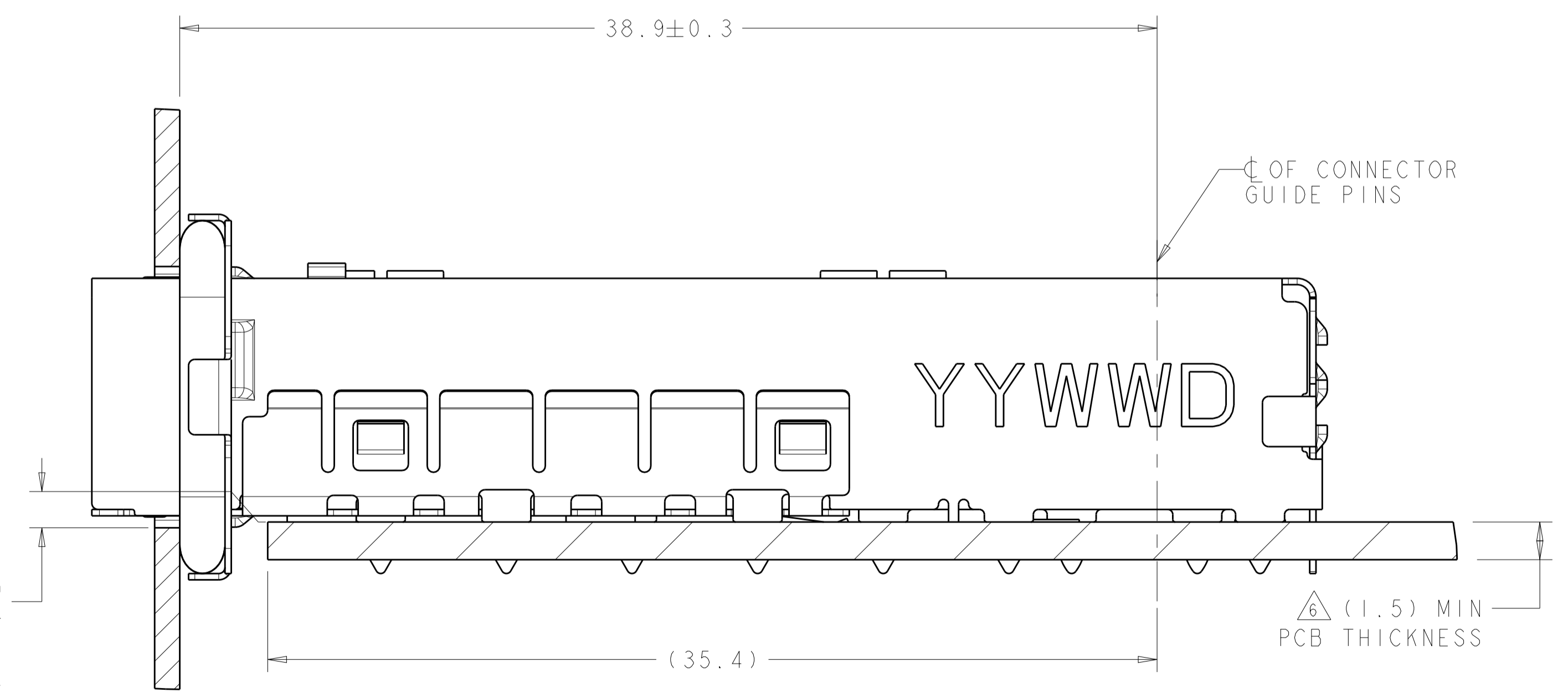

2180900-1
MOUNTED ON PC BOARD
SHOWN THRU RECOMMENDED BEZEL

THIS DRAWING IS A CONTROLLED DOCUMENT.		DWN: B. MATTHEWS 20JUL2011	TE Connectivity
DIMENSIONS: mm		CHK: M. SCHMITT 20JUL2011	
TOLERANCES UNLESS OTHERWISE SPECIFIED:		APVD: M. SCHMITT 20JUL2011	NAME: SFP+ ENHANCED 1X2 CAGE ASSEMBLY, PRESS-FIT, EMI GASKET
0 PLC	±0.13	PRODUCT SPEC	SIZE: CAGE CODE DRAWING NO
1 PLC	±0.1	108-2364	RESTRICTED TO
2 PLC	±0.08	APPLICATION SPEC	A100779C=2180900
3 PLC	±0.05	114-13120	SCALE: 6:1 SHEET 1 OF 2 REV A
4 PLC	±0.05	WEIGHT	
ANGLES	±0.1	CUSTOMER DRAWING	
MATERIAL			
FINISH			

2180900-1
PART NUMBER

LOC	DIST	REV	DATE	BY	APPV
GP	00				

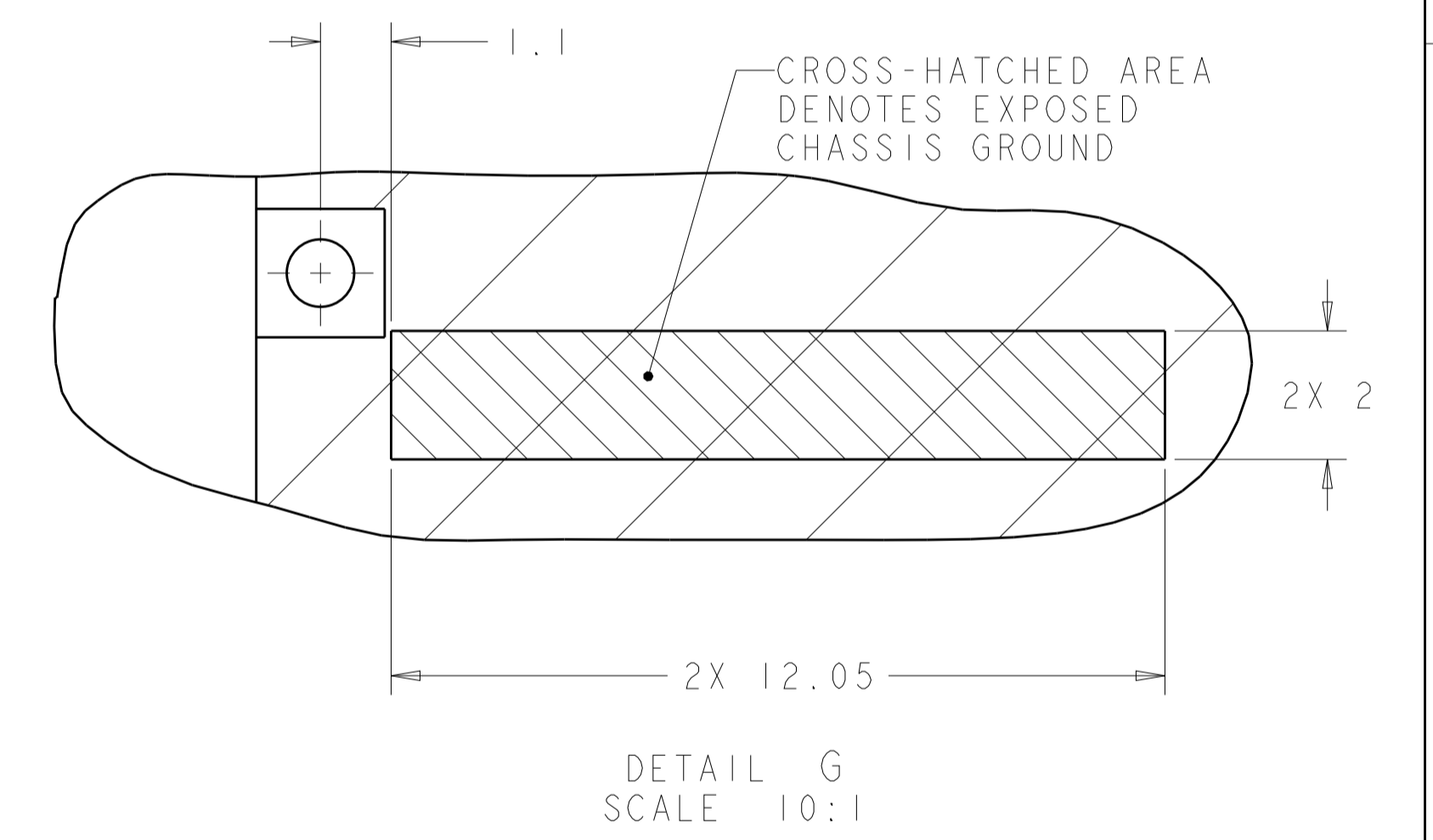
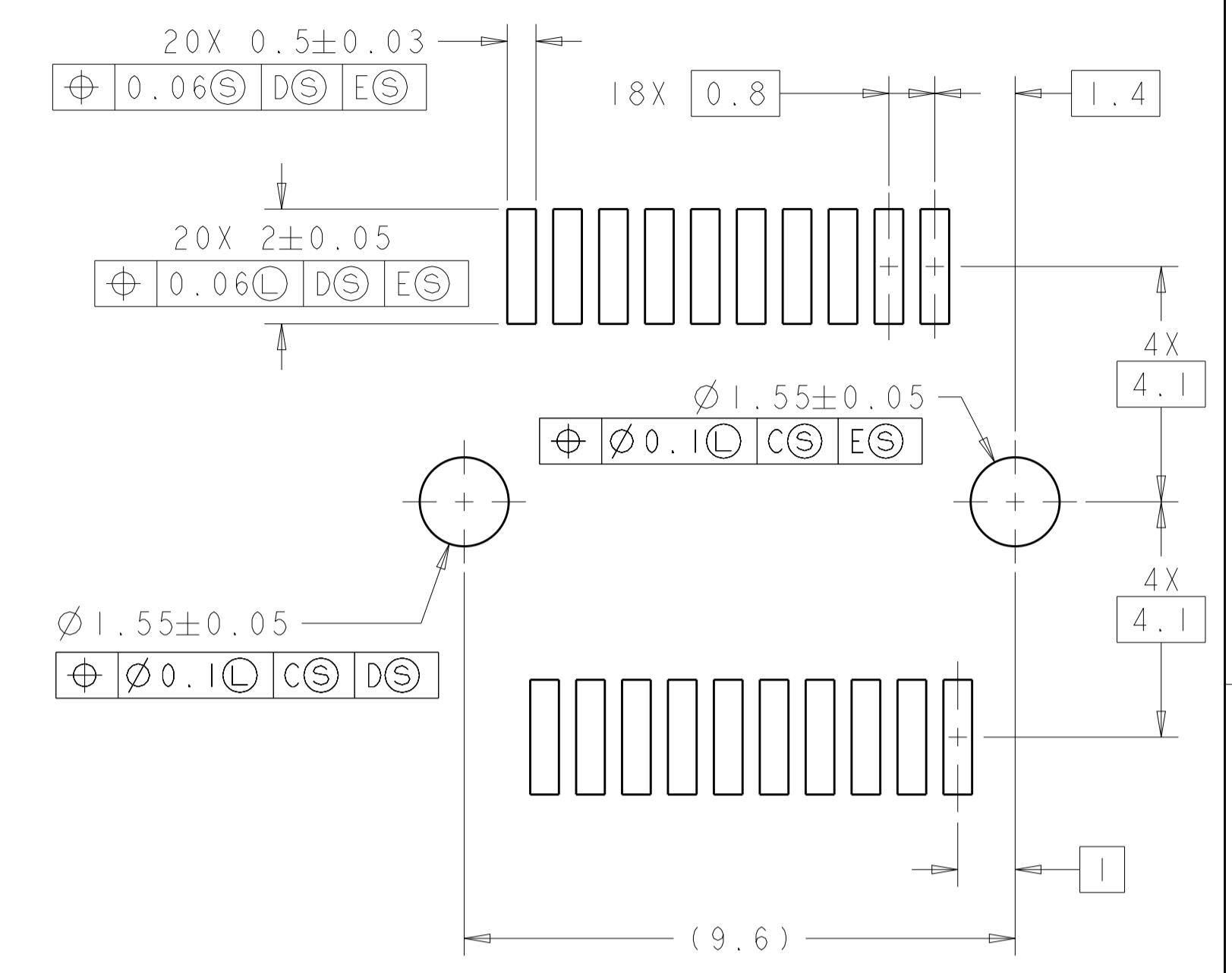
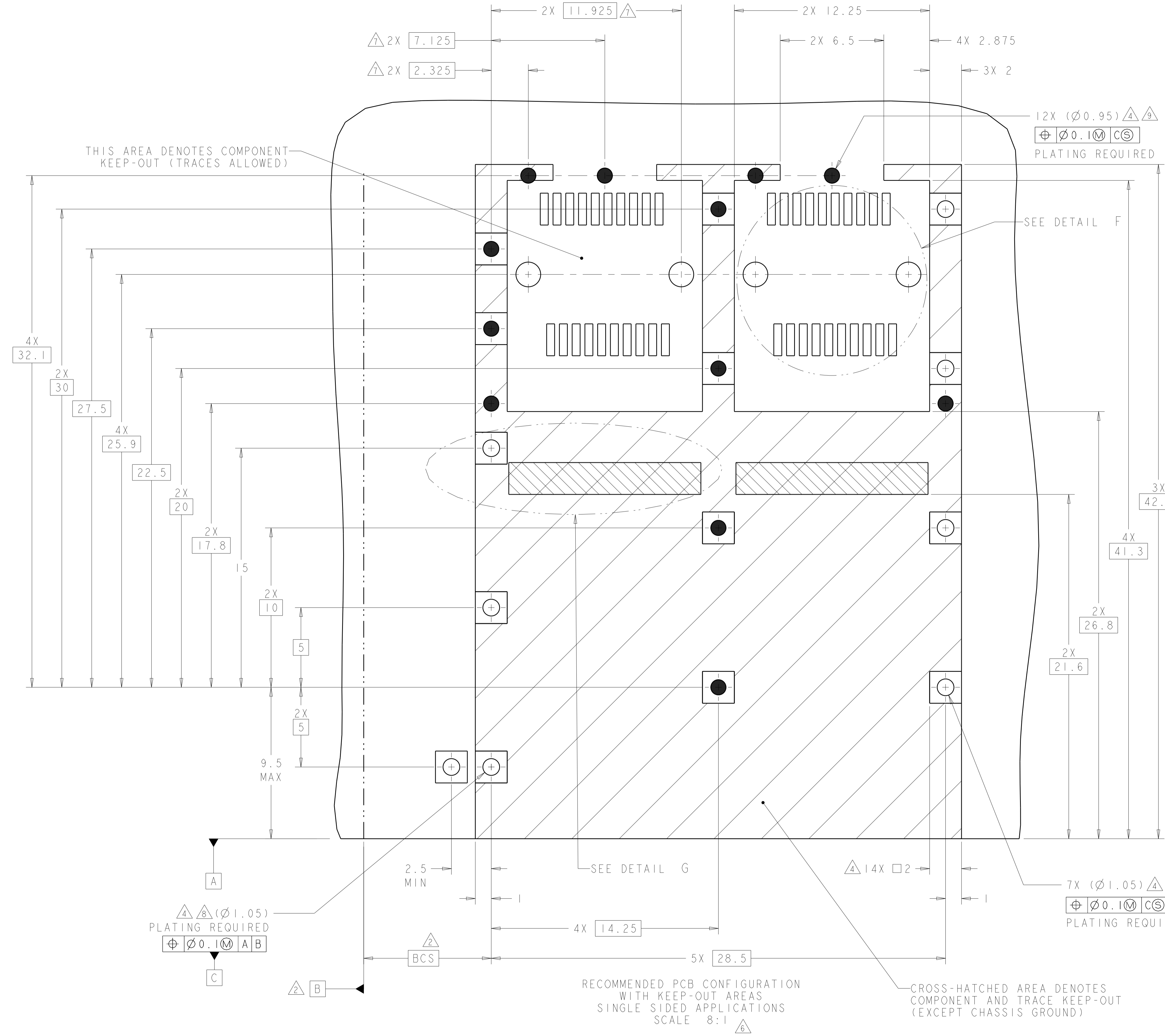

THIS DRAWING IS A CONTROLLED DOCUMENT.		OWN: B. MATTHEWS 20JUL2011	TE Connectivity
DIMENSIONS: mm		CHK: M. SCHMITT 20JUL2011	
TOLERANCES UNLESS OTHERWISE SPECIFIED:		APVD: M. SCHMITT 20JUL2011	NAME: SFP+ ENHANCED 1X2 CAGE ASSEMBLY, PRESS-FIT, EMI GASKET PRODUCT SPEC: 108-2364 APPLICATION SPEC: 114-13120 WEIGHT: - CUSTOMER DRAWING
0 PLC ±0.13		PRODUCT SPEC: 108-2364	
1 PLC ±0.1		APPLICATION SPEC: 114-13120	
2 PLC ±0.08		WEIGHT: -	
3 PLC ±0.05		SIZE: A100779C=2180900	RESTRICTED TO: -
4 PLC ±0.05		SCALE: 6:1	SHEET: 2 OF 2
ANGLES ±0.5		REV: A	
FINISH: -			

单击下面可查看定价，库存，交付和生命周期等信息

[>>TE Connectivity\(泰科\)](#)