

REVISION(S)			
LTR	DESCRIPTION	INIT	APP'D
O	NEW RELEASE	E.T 8/25/04	B.P 9/10/04
A	ECR-06-013536	E.T 6/6/06	V.K 6/6/06

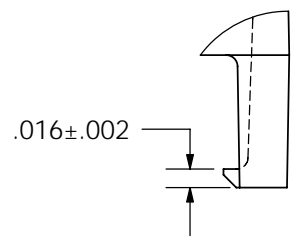

DETAIL A  
SCALE = 6X

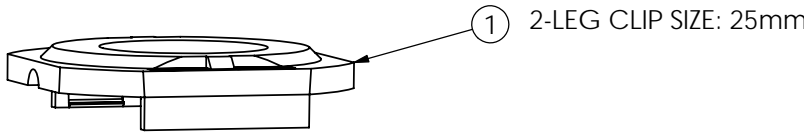
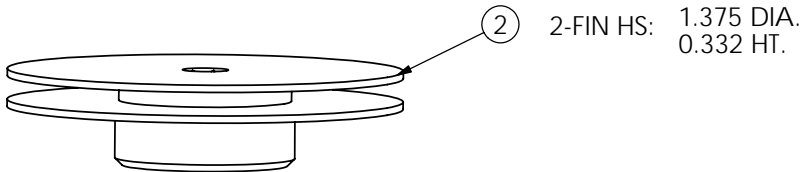
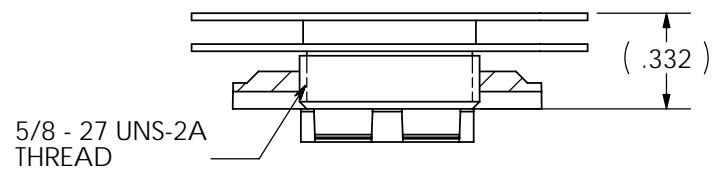
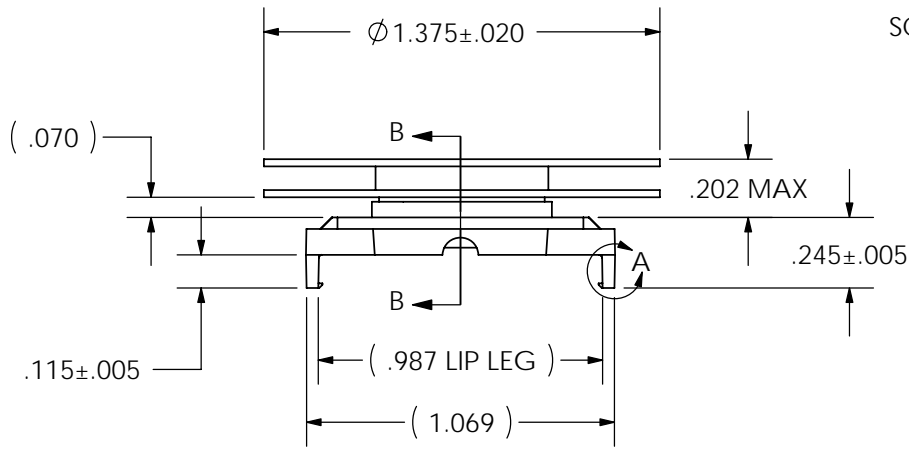

SECTION B-B

NOTE:

- MATERIAL:  
HEAT SINK: ALUM. (BLACK ANODIZE)  
CLIP: BLACK PEI (UL94-VO)
- BEFORE THE HEATSINK APPLICATION, THE USER SHOULD IDENTIFY THE SPECIFICATION OF MAXIMUM LOAD ON THE BGA PACKAGE.  
HEATSINK TORQUE SPECIFICATIONS CONVERTED TO FORCE.  
BARE DIE PACKAGE:  
1.5 INCH - LB TORQUE = 8.5 LBS FORCE  
2.0 INCH - LB TORQUE = 11.4 LBS FORCE  
FULL SIZE LID PACKAGE:  
1.5 INCH - LB TORQUE = 8.3 LBS FORCE  
2.0 INCH - LB TORQUE = 11.1 LBS FORCE
- REMOVE CLIP WITH REMOVAL TOOL P/N: 1542616-1.
- RoHS COMPLIANT AND CERTIFIED.

ITEM	DESCRIPTION	QTY	DO NOT SCALE	tyco / Electronics Attleboro Falls Massachusetts 02763			CONFIDENTIAL PROPERTY OF TYCO ELECTRONICS. NOT TO BE DISCLOSED TO OTHERS. REPRODUCED OR USED FOR ANY PURPOSES EXCEPT AS AUTHORIZED IN WRITING BY AN AUTHORIZED OFFICIAL OF TYCO. MUST BE RETURNED TO TYCO ON DEMAND, ON COMPLETION OF ORDERS OR OTHER PURPOSES FOR WHICH LENT.		TITLE: 25mm HEATSINK ASSEMBLY (HTS389-P)	
1	MOUNTING CLIP	1	UNLESS OTHERWISE SPECIFIED TOLERANCES ARE: .XX ± .XXX ± .XXXX ± ANGLES ± °	DRAWN BY:	DATE	MATERIAL: SEE NOTE	DIMENSIONS ARE IN: INCHES	SCALE: 1.5:1	PART NO: 2-1542002-2	SHEET: 1 OF 1
2	HEAT SINK	1		ENGINEER:	DATE					
3	INTERFACE	1		FILENAME	PROJECT	SYSTEM				

单击下面可查看定价，库存，交付和生命周期等信息

[>>TE Connectivity\(泰科\)](#)