

THIS DRAWING IS UNPUBLISHED. RELEASED FOR PUBLICATION  
 © COPYRIGHT BY TYCO ELECTRONICS CORPORATION. ALL INTERNATIONAL RIGHTS RESERVED.

LOC	DIST	REVISIONS			
P	LTR	DESCRIPTION	DATE	DWN	APVD
G	14	P			
		P	REVISED PER ECR-10-003079	03MAR10	JR TM

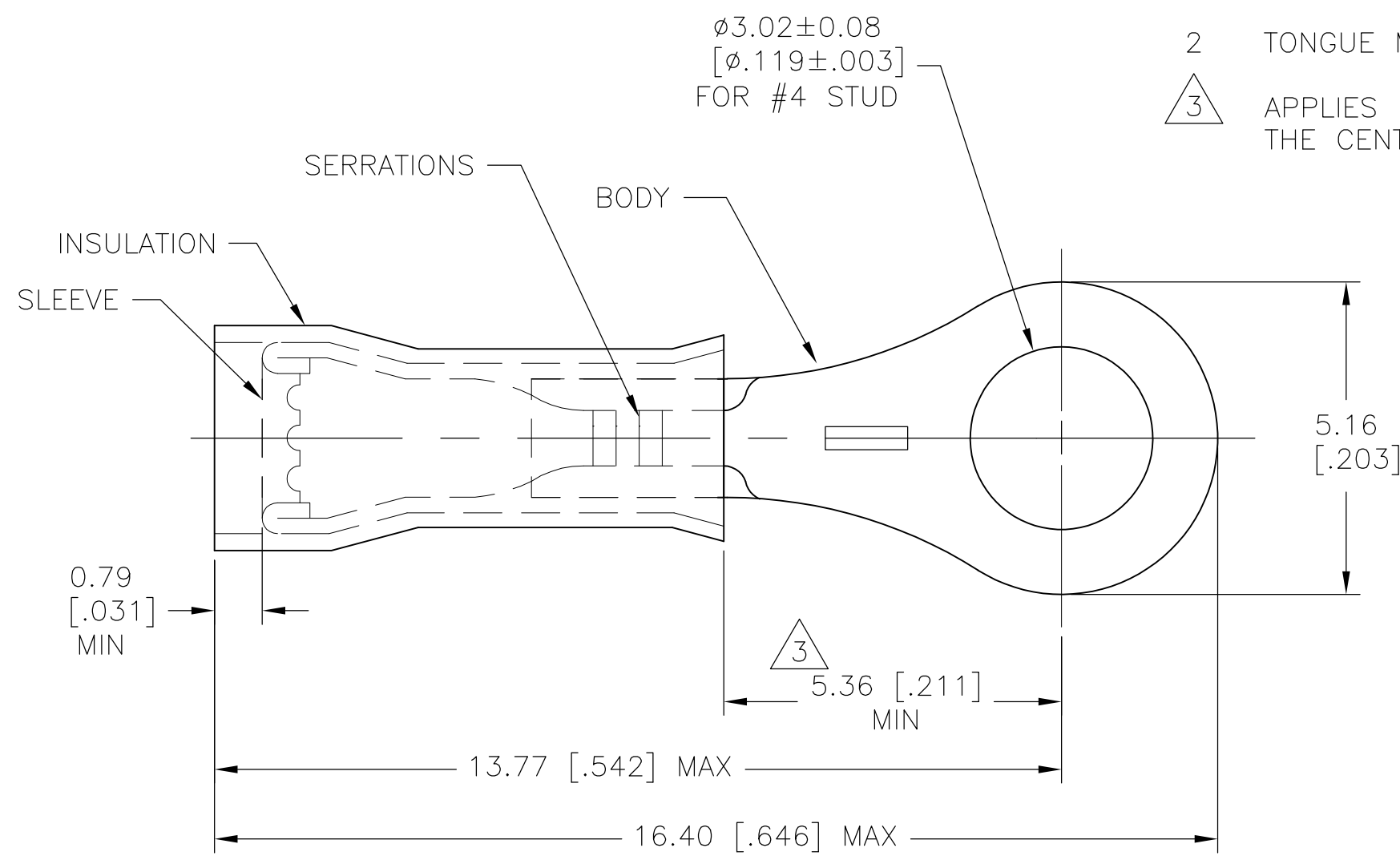

- 1 FOR 1.27 [.050] TO 2.08 [.082] WIRE INSULATION DIA
- 2 TONGUE MATERIAL THK = 0.46 ± 0.05 [.018 ± .002]
- △ 3 APPLIES FROM THE METAL EDGE OF THE BARREL TO THE CENTER OF THE STUD

QTY	DESCRIPTION	MATERIAL & FINISH	PART NO
5000	321017 ON TAPE	BODY & SLEEVE: COPPER (ASTM-B152) TIN PL (ASTM-B545)	OBSOLETE <del>2-321017-3</del>
1000	WIRE TERMINAL	INSULATION: YELLOW , PVC	321017

THIS DRAWING IS A CONTROLLED DOCUMENT.		DWN JR RUTH 03MAR10	Tyco Electronics Corporation Harrisburg, PA 17105-3608	
DIMENSIONS: mm [INCHES]		CHK JEFF RUTH 03MAR10	NAME TOM MICHIELUTTI	
TOLERANCES UNLESS OTHERWISE SPECIFIED:		APVD 03MAR10	PRODUCT SPEC ---	
0 PLC ± -		APPLICATION SPEC ---		
1 PLC ± -		SIZE A3		
2 PLC ± -		CAGE CODE 00779		
3 PLC ± 0.20 [.008]		DRAWING NO G-321017		
4 PLC ± -		RESTRICTED TO ---		
ANGLES ± 5°		SCALE 10:1		
MATERIAL SEE TABLE	FINISH SEE TABLE	WEIGHT -		SHEET 1 OF 1
CUSTOMER DRAWING		REV P		

单击下面可查看定价，库存，交付和生命周期等信息

[>>TE Connectivity\(泰科\)](#)