

LOC	DIST	REVISIONS			
GP	00	REV	DATE	DWN	APVD
		A	RELEASED PER ECO-08-011133	14MAY2008	ZMR DLG

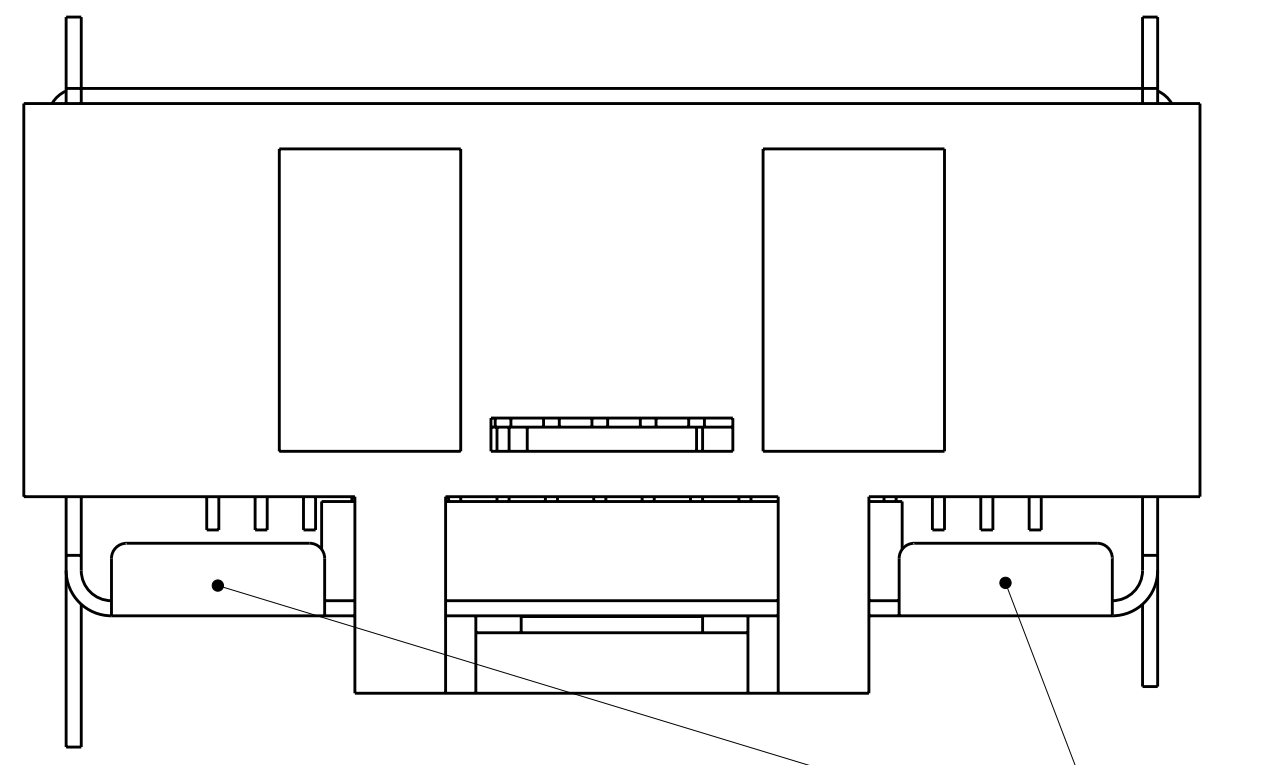

KEYING
 PICK AND PLACE DEVICE
 VERTICAL SHIELD ASSEMBLY

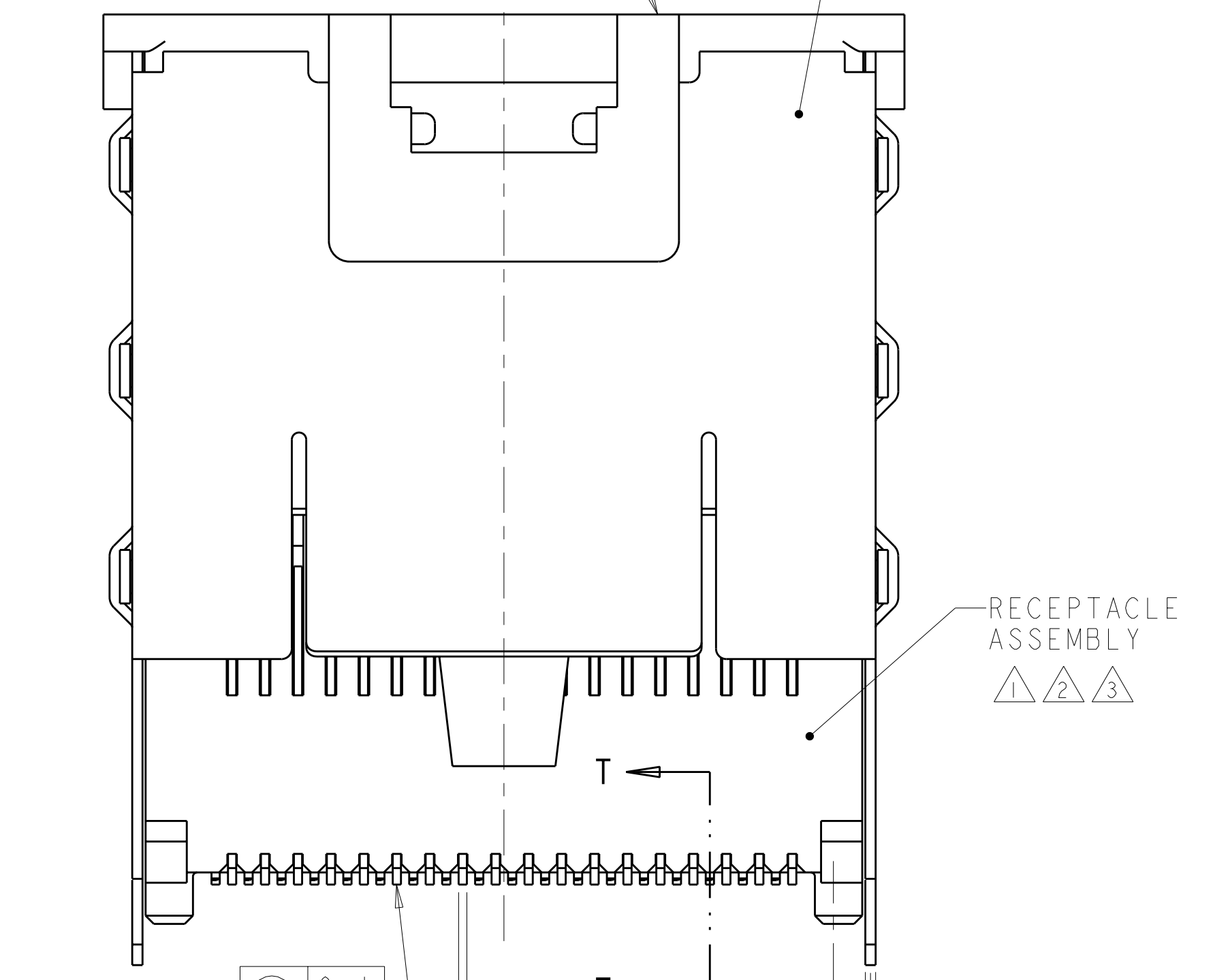

RECEPTACLE ASSEMBLY
 ALL CONTACT SOLDER TAIL SURFACES
 (0.1) ALL CONTACT SOLDER TAIL SURFACES
 (0.2) B PLC
 (0.25) TYP
 (0.4) Z V S W S
 (0.9) TYP

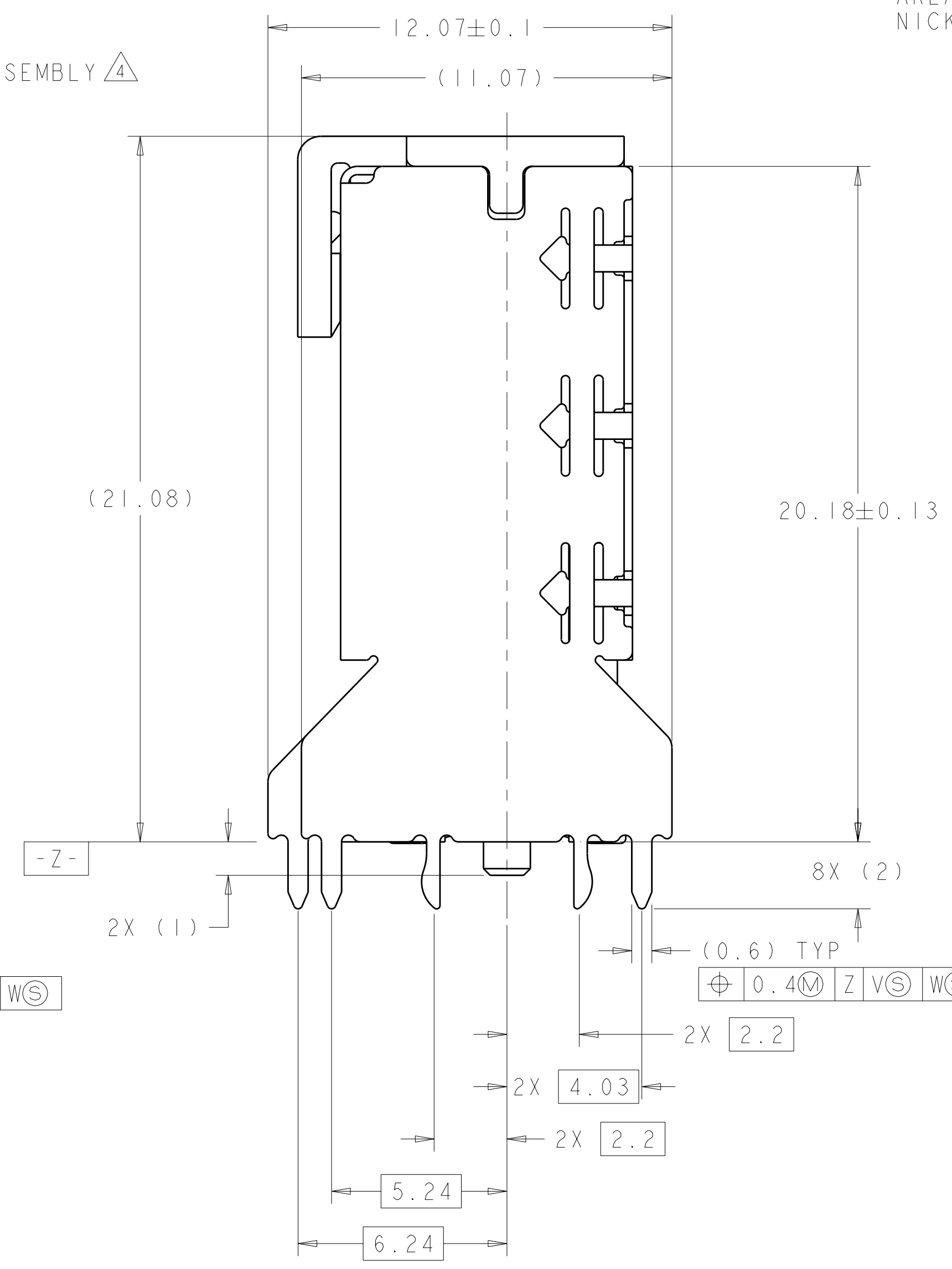
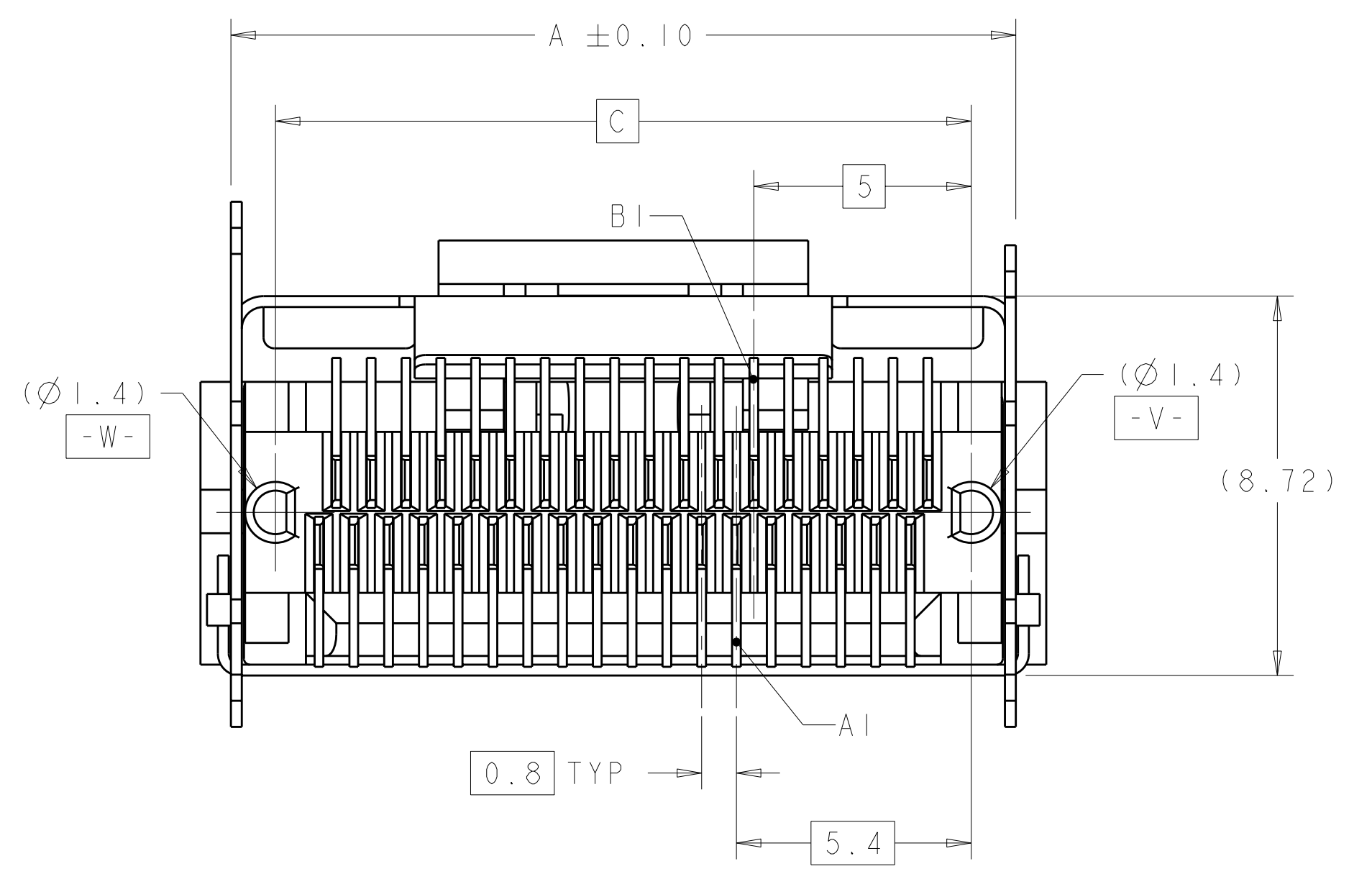

1888174-2 AS SHOWN

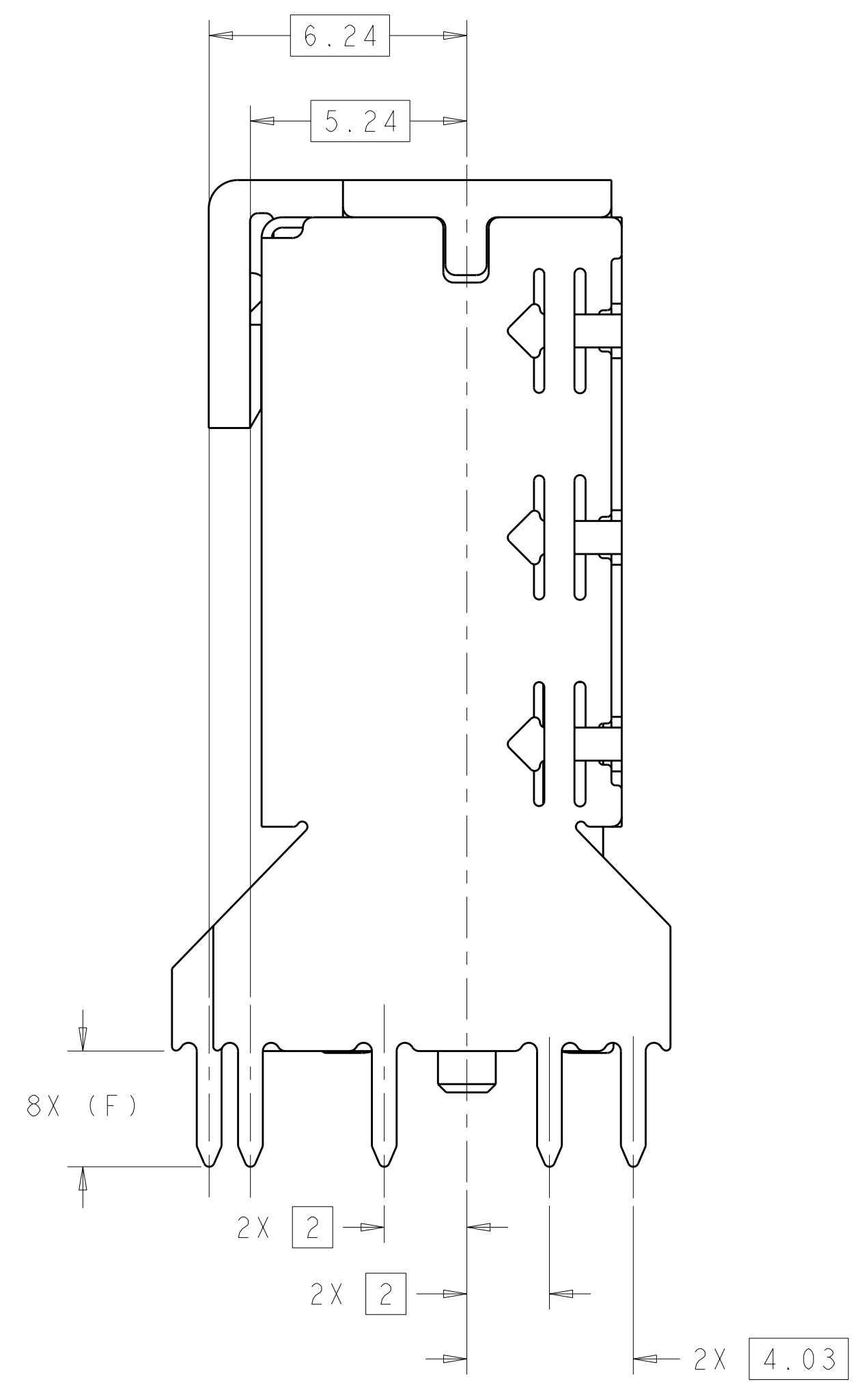

1888174-4 AND 1888174-6 AS SHOWN

- 1 MATERIAL: LCP, BLACK.
- 2 MATERIAL: PHOSPHOR BRONZE PER ASTM B 103.
- 3 FINISH: 0.76µm MIN GOLD PLATE PER ASTM B 488, APPLIES TO INTERFACE AREA AND 2.03µm MIN TIN PLATE SOLDER TAILS, ALL OVER 3.81µm MIN NICKEL PLATE PER QQ-N-290.
- 4 MATERIAL: NICKEL-SILVER PER ASTM B 122.
- 5 DATUM AND BASIC DIMENSION ESTABLISHED BY CUSTOMER.
- 6 CONTACT TAILS TO BE 0.25 MAX BELOW OR FLUSH WITH DATUM Z.
- 7 REFER TO CUSTOMER DRAWING 1888020 FOR CONNECTOR DETAILS.
- 8 FINISH: 0.38µm MIN GOLD PLATE PER ASTM B 488, APPLIES TO INTERFACE AREA AND 2.03µm MIN TIN PLATE SOLDER TAILS, ALL OVER 3.81µm MIN NICKEL PLATE PER QQ-N-290.

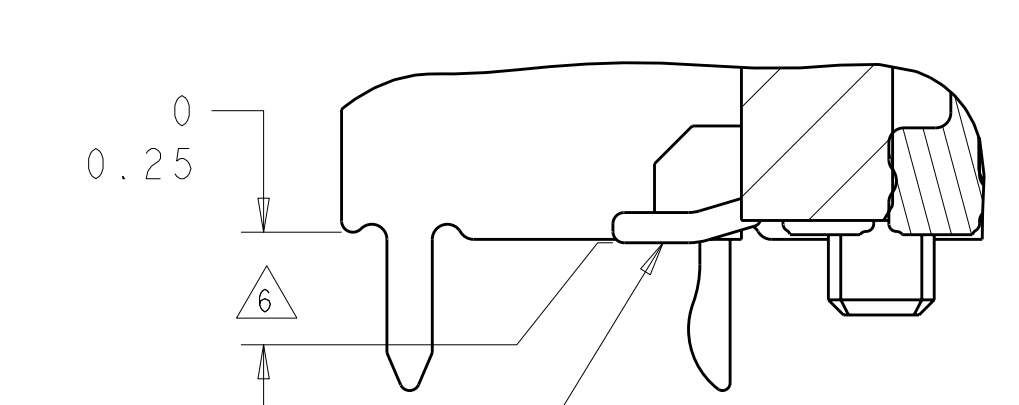

VERTICAL CONTACT
 SECTION T-T
 SCALE 10:1

FINISH	SHIELD TYPE	N	F	E	D	C	B	A	POSN	PART NUMBER
		THRU-HOLE	36	3.5	17.8	16	16	36	18.05	36
THRU-HOLE	36	2.8	17.8	16	16	36	18.05	36	1888174-8	
PRESS-FIT	36	-	17.8	16	16	36	18.05	36	1888174-7	
THRU-HOLE	36	3.5	17.8	16	16	36	18.05	36	1888174-6	
THRU-HOLE	36	2.8	17.8	16	16	36	18.05	36	1888174-4	
PRESS-FIT	36	-	17.8	16	16	36	18.05	36	1888174-2	

DIMENSIONS: mm 		TOLERANCES UNLESS OTHERWISE SPECIFIED: 9 PLC ± 8 PLC ± 5 PLC ± 4 PLC ± ANGLES ±		DWN M.E. SHIRK 200CT05 CHK R.R. HENRY 200CT05 APVD R.R. HENRY 200CT05		Tyco Electronics Harrisburg, PA 17105-3608	
MATERIAL: LCP, BLACK FINISH: SEE TABLE		PRODUCT SPEC: 108-2234 APPLICATION SPEC:		NAME: EVERCLEAR Mini-SAS VERTICAL INTERNAL RECEPTACLE ASSY WITH DUAL KEYED SHELL		SIZE: CAGE CODE DRAWING NO: A1100779C=1888174 RESTRICTED TO:	
CUSTOMER DRAWING		SCALE: 8:1		SHEET: 1 OF 2		REV: A	

LOC	DIST	REVISIONS			
P	LTN	DESCRIPTION	DATE	OWN	APVD
GP	00	SEE SHEET 1	-	-	-

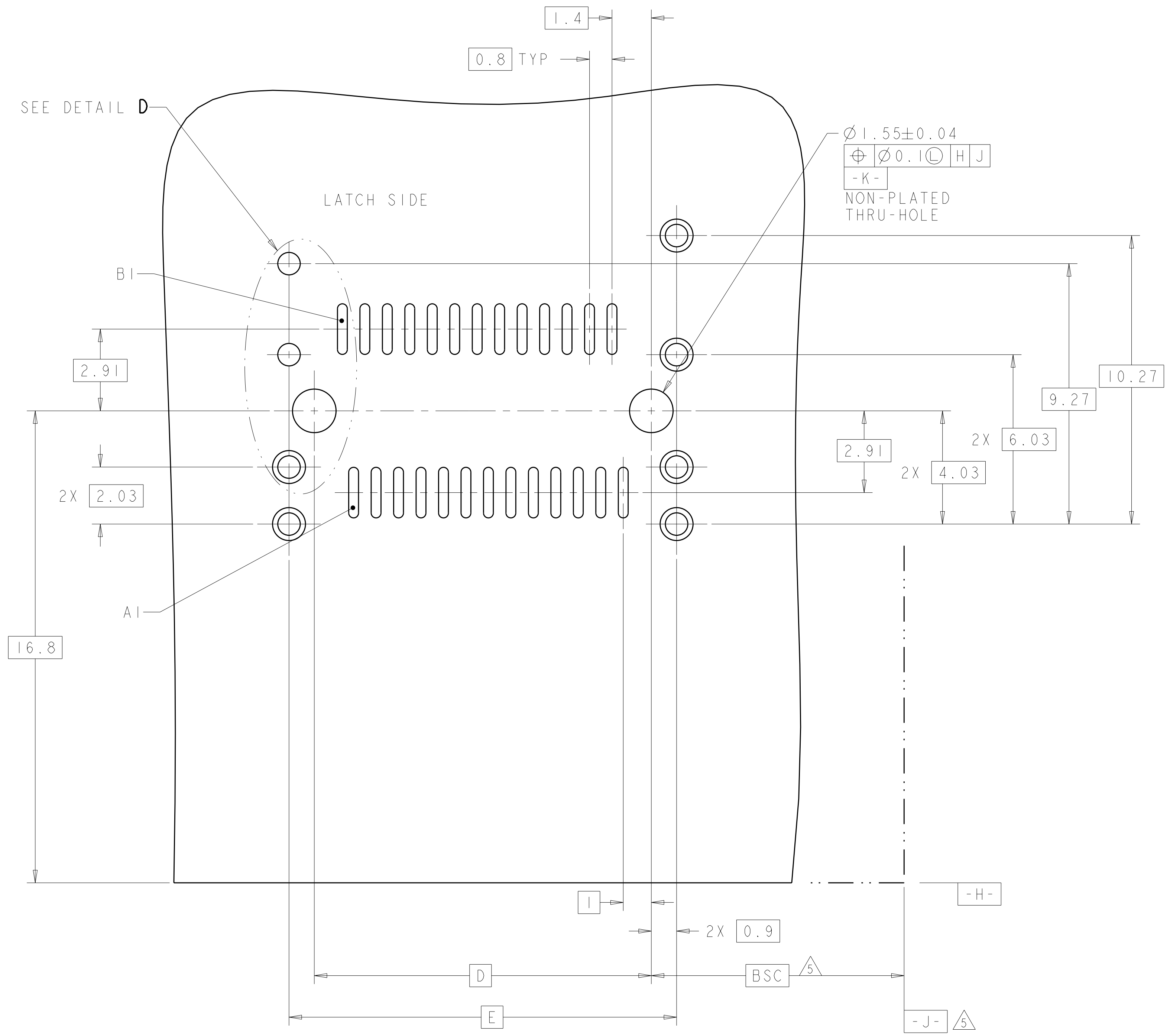

RECOMMENDED PCB LAYOUT
 SCALE 10:1

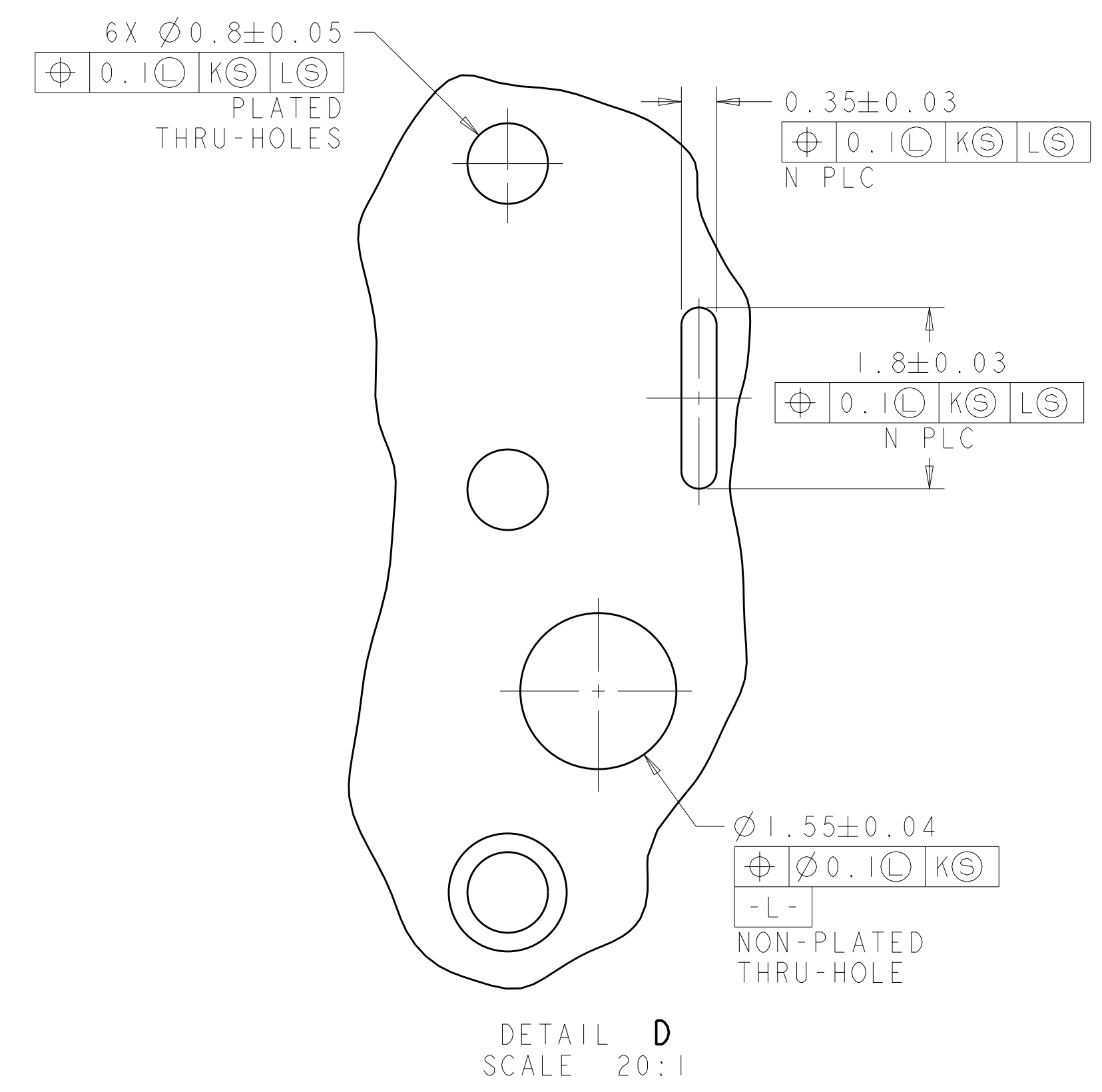

<small>THIS DRAWING IS UNPUBLISHED. RELEASED FOR PUBLICATION. ALL RIGHTS RESERVED. THIS DRAWING IS UNPUBLISHED. RELEASED FOR PUBLICATION. ALL RIGHTS RESERVED.</small>		DWN M.E. SHIRK 200CT05 CHK R.R. HENRY 200CT05 APVD R.R. HENRY 200CT05	Tyco Electronics Harrisburg, PA 17105-3608
DIMENSIONS: mm 	TOLERANCES UNLESS OTHERWISE SPECIFIED: 0 PLC ± 1 PLC ± 2 PLC ± 3 PLC ± 4 PLC ± ANGLES ± FINISH ±	NAME EVERCLEAR Mini-SAS VERTICAL INTERNAL RECEPTACLE ASSY WITH DUAL KEYED SHELL	RESTRICTED TO CUSTOMER DRAWING
MATERIAL	FINISH	PRODUCT SPEC 108-2234 APPLICATION SPEC	SCALE 8:1 SHEET 2 OF 2 REV A

单击下面可查看定价，库存，交付和生命周期等信息

[>>TE Connectivity\(泰科\)](#)