

THIS DRAWING IS UNPUBLISHED. RELEASED FOR PUBLICATION 20
 © COPYRIGHT 20 BY - ALL RIGHTS RESERVED.

LOC		DIST		REVISIONS			
P	LTR	DESCRIPTION	DATE	DWN	APVD		
G4		REVISED PER ECO-11-004587	11MAR2011	RK	HMR		

UNREEL DIRECTION OF REVERSE TAPED
 →

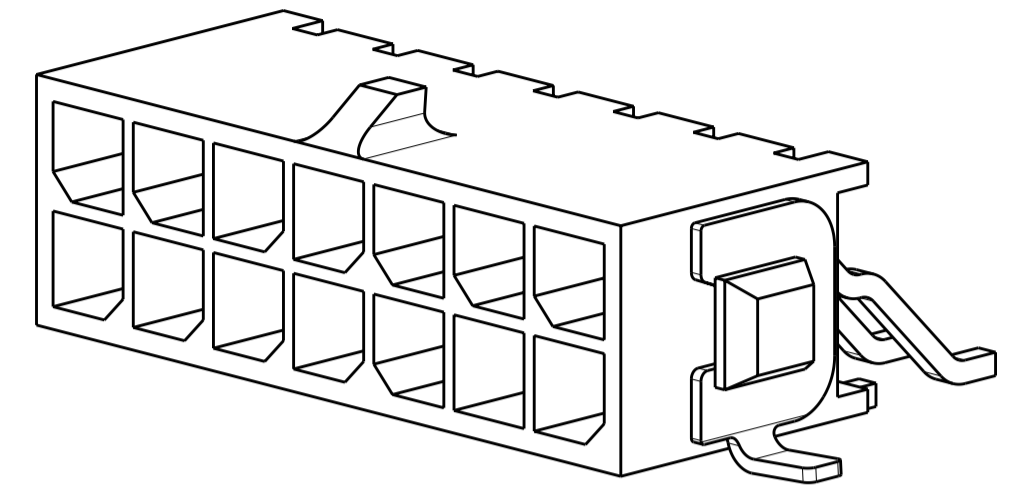
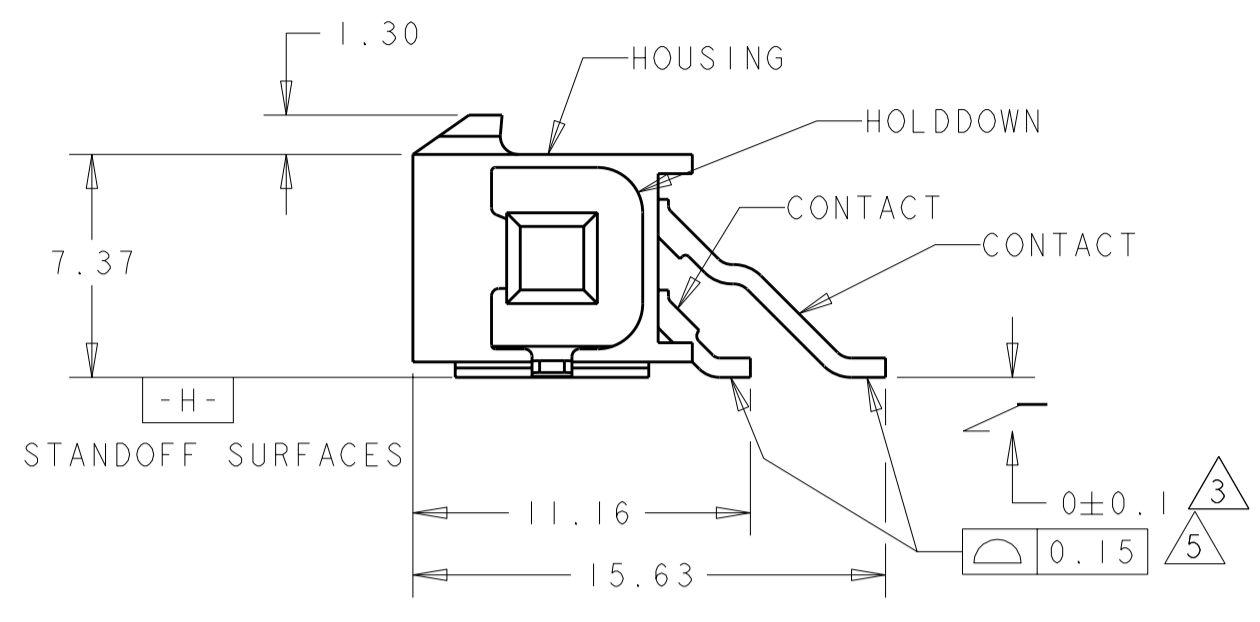
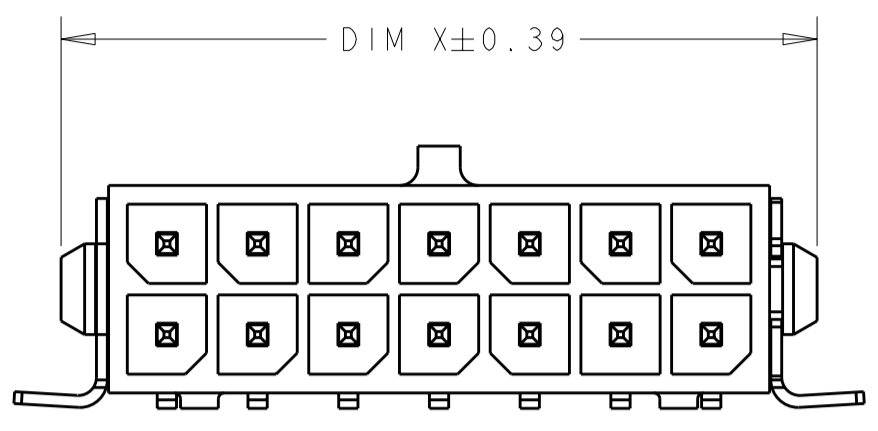

SCALE 5:1

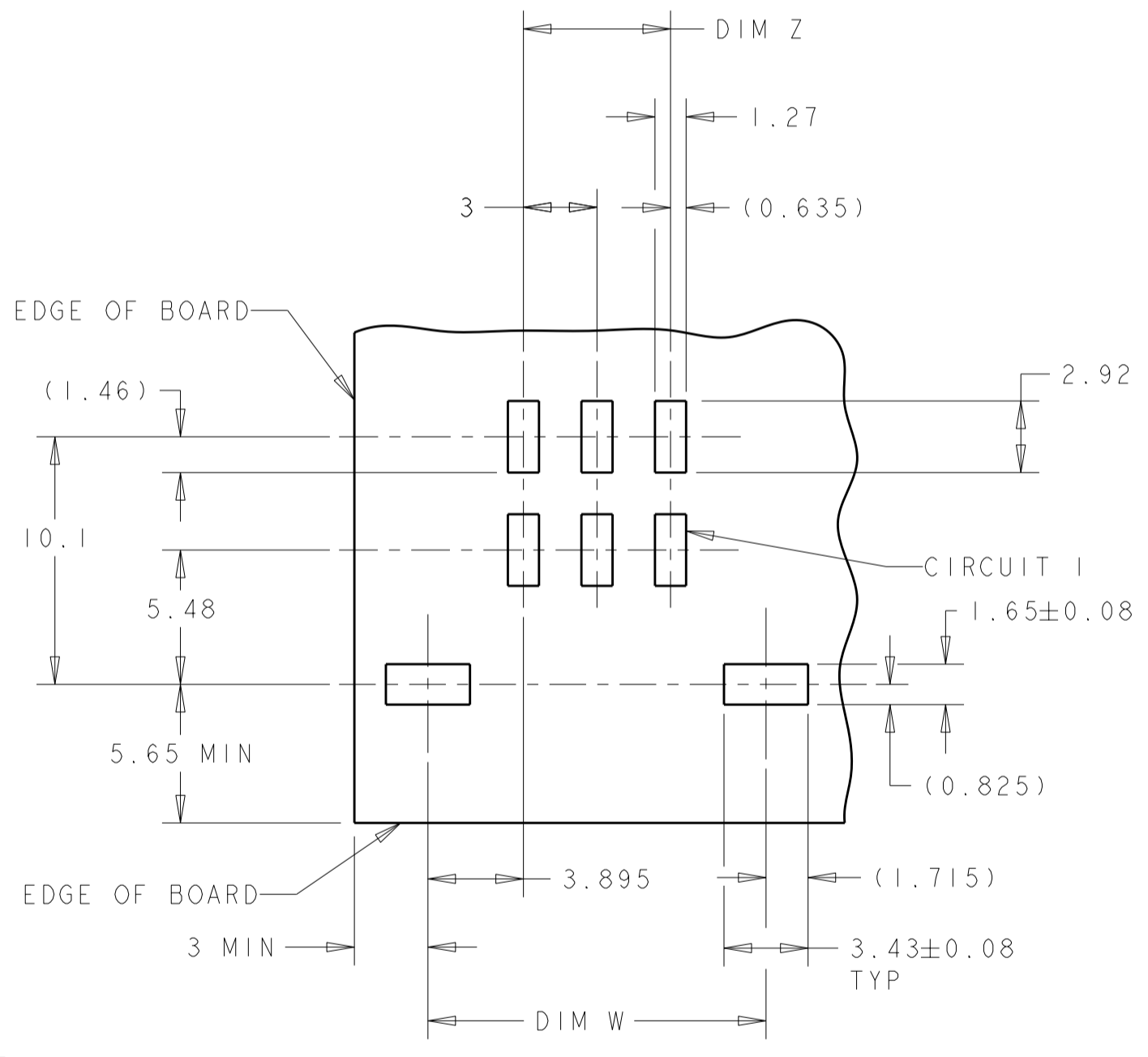
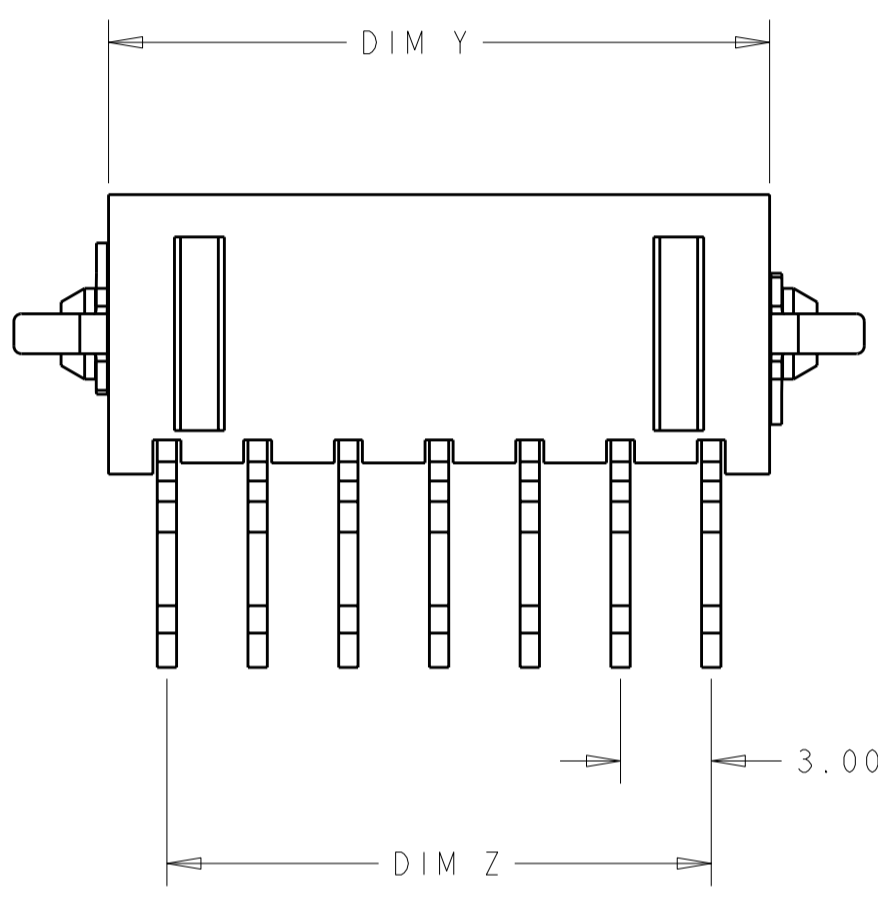

RECOMMENDED PCB LAYOUT (COMPONENT SIDE)

- 1 MATERIAL;
CONTACTS - BRASS.
HOUSING - UL 94V-0 RATED HIGH TEMP NYLON, COLOR; BLACK.
HOLDDOWNS - PHOSPHOR BRONZE.
- 2 PLATING;
CONTACTS - 0.76µm MINIMUM GOLD OVER 2.54µm MINIMUM NICKEL ON MATING AREA.
2.54µm TIN-LEAD MINIMUM OVER 2.54µm NICKEL MINIMUM ON SOLDER TAIL.
HOLDDOWNS - 2.54µm TIN-LEAD.
- 3 DIMENSION APPLIES TO SOLDER TAIL SURFACES AND STANDOFF SURFACES.
- 4 RECOMMENDED PC BOARD THICKNESS OF 1.57.
- 5 ALL SOLDER TAILS AND HOLDDOWNS.
- 6 PLATING;
CONTACTS - 0.76µm MINIMUM GOLD OVER 2.54µm MINIMUM NICKEL ON MATING AREA.
2.54µm MATTE TIN MINIMUM OVER 2.54µm NICKEL MINIMUM ON SOLDER TAIL.
HOLDDOWNS - 2.54µm MATTE TIN.

REVERSE TAPED	FINISH	DIM Y	DIM W	DIM Z	DIM X	NO. OF POSN.	PART NUMBER
REVERSE TAPED	6	12.86	16.79	9.00	16.00	8	6-794629-8
REVERSE TAPED	6	6.86	10.79	3.00	10.00	4	6-794629-4
TAPED	6	36.86	40.79	33.00	40.00	24	5-794629-4
TAPED	6	33.86	37.79	30.00	37.00	22	5-794629-2
TAPED	6	30.86	34.79	27.00	34.00	20	5-794629-0
TAPED	6	27.86	31.79	24.00	31.00	18	4-794629-8
TAPED	6	24.86	28.79	21.00	28.00	16	4-794629-6
TAPED	6	21.86	25.79	18.00	25.00	14	4-794629-4
TAPED	6	18.86	22.79	15.00	22.00	12	4-794629-2
TAPED	6	15.86	19.79	12.00	19.00	10	4-794629-0
TAPED	6	12.86	16.79	9.00	16.00	8	3-794629-8
TAPED	6	9.86	13.79	6.00	13.00	6	3-794629-6
TAPED	6	6.86	10.79	3.00	10.00	4	3-794629-4
LOOSE PIECE	6	3.86	7.79	-	7.00	2	3-794629-2
TAPED	2	36.86	40.79	33.00	40.00	24	2-794629-4
TAPED	2	33.86	37.79	30.00	37.00	22	2-794629-2
TAPED	2	30.86	34.79	27.00	34.00	20	2-794629-0
TAPED	2	27.86	31.79	24.00	31.00	18	1-794629-8
TAPED	2	24.86	28.79	21.00	28.00	16	1-794629-6
TAPED	2	21.86	25.79	18.00	25.00	14	1-794629-4
TAPED	2	18.86	22.79	15.00	22.00	12	1-794629-2
TAPED	2	15.86	19.79	12.00	19.00	10	1-794629-0
TAPED	2	12.86	16.79	9.00	16.00	8	794629-8
TAPED	2	9.86	13.79	6.00	13.00	6	794629-6
TAPED	2	6.86	10.79	3.00	10.00	4	794629-4
LOOSE PIECE	2	3.86	7.79	-	7.00	2	794629-2

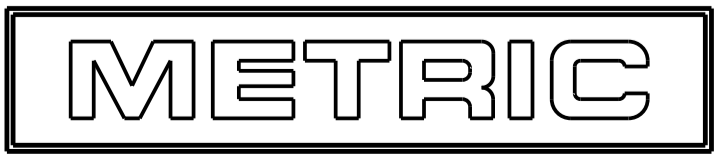

THIS DRAWING IS A CONTROLLED DOCUMENT. DWN: K. WHITAKER 19MAR2003
 CHK: C. JONES 19MAR2003
 APVD: C. JONES 19MAR2003

STE TE Connectivity

NAME: SURFACE MOUNT, RIGHT ANGLE, SURFACE MOUNT HOLDDOWN, ASSEMBLY, 30 GOLD HEADER, DUAL ROW, MICRO MATE-N-LOK™

SIZE: A2 CAGE CODE: 0779 DRAWING NO: 794629

MATERIAL: SEE TABLE FINISH: SEE TABLE WEIGHT: -

CUSTOMER DRAWING SCALE: 4:1 SHEET 1 OF 1 REV: G4

单击下面可查看定价，库存，交付和生命周期等信息

[>>TE Connectivity\(泰科\)](#)