

LOC		DIST		REVISIONS			
P	LTR	DESCRIPTION	DATE	DN	APVD		
E		REVISED PER ECO-09-002944	19MAR2009	CR	SB		

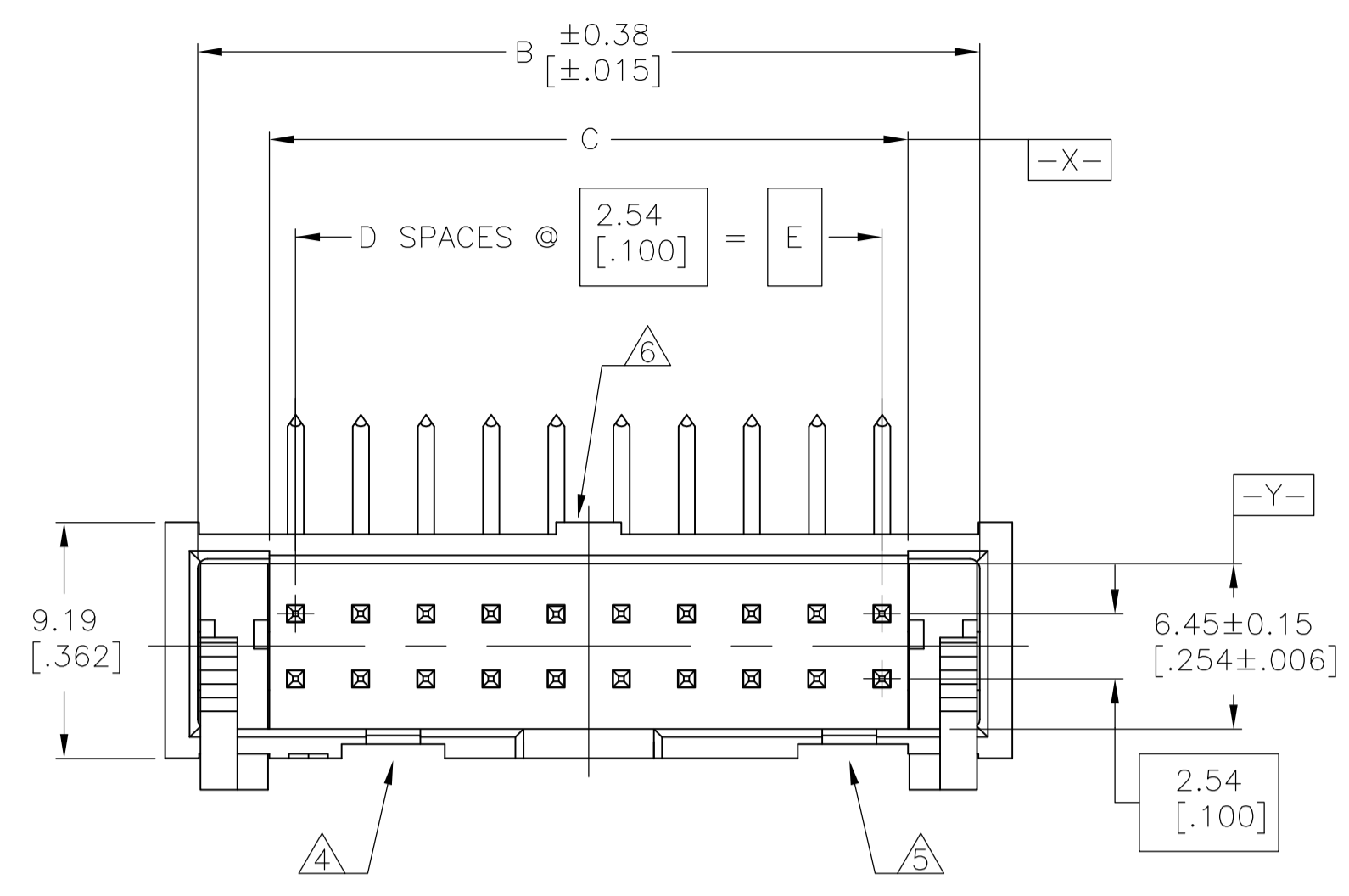

- ⚠ HOUSING: PBT, UL94V-0, COLOR: BLUE.
POSTS: PHOSPHOR BRONZE.
LATCHES: ZINC ALLOY.
- ⚠ POSTS: GOLD FLASH OVER PALLADIUM-NICKEL PLATE, 0.76μm[.000030] MIN TOTAL ON MATING AREA, 2.54μm[.000100] MIN TIN PLATE ON SOLDER-TAIL, ALL OVER 1.27μm[.000050] MIN NICKEL UNDERPLATE ON ENTIRE POST.
OR
0.76μm[.000030] MIN GOLD PLATE ON MATING AREA, 2.54μm[.000100] MIN TIN PLATE ON THE SOLDER-TAIL, 1.27μm[.000050] MIN NICKEL UNDERPLATE ON THE ENTIRE POST.
LATCHES: BLACK NICKEL OVER COPPER.
- ⚠ DATUMS S & T TO BE ESTABLISHED BY CUSTOMER.
- ⚠ NO KEYING SLOT ON THIS END FOR 10, 12 & 14 POSITION ASSEMBLIES.
- ⚠ NO KEYING SLOT ON THIS END FOR 10 POSITION ASSEMBLY.
- ⚠ NO STANDOFF FOR 10, 12, 14 & 16 POSITION ASSEMBLIES.
- ⚠ ALTERNATE LOCATION/ORIENTATION FOR POSITION #1 INDICATOR.

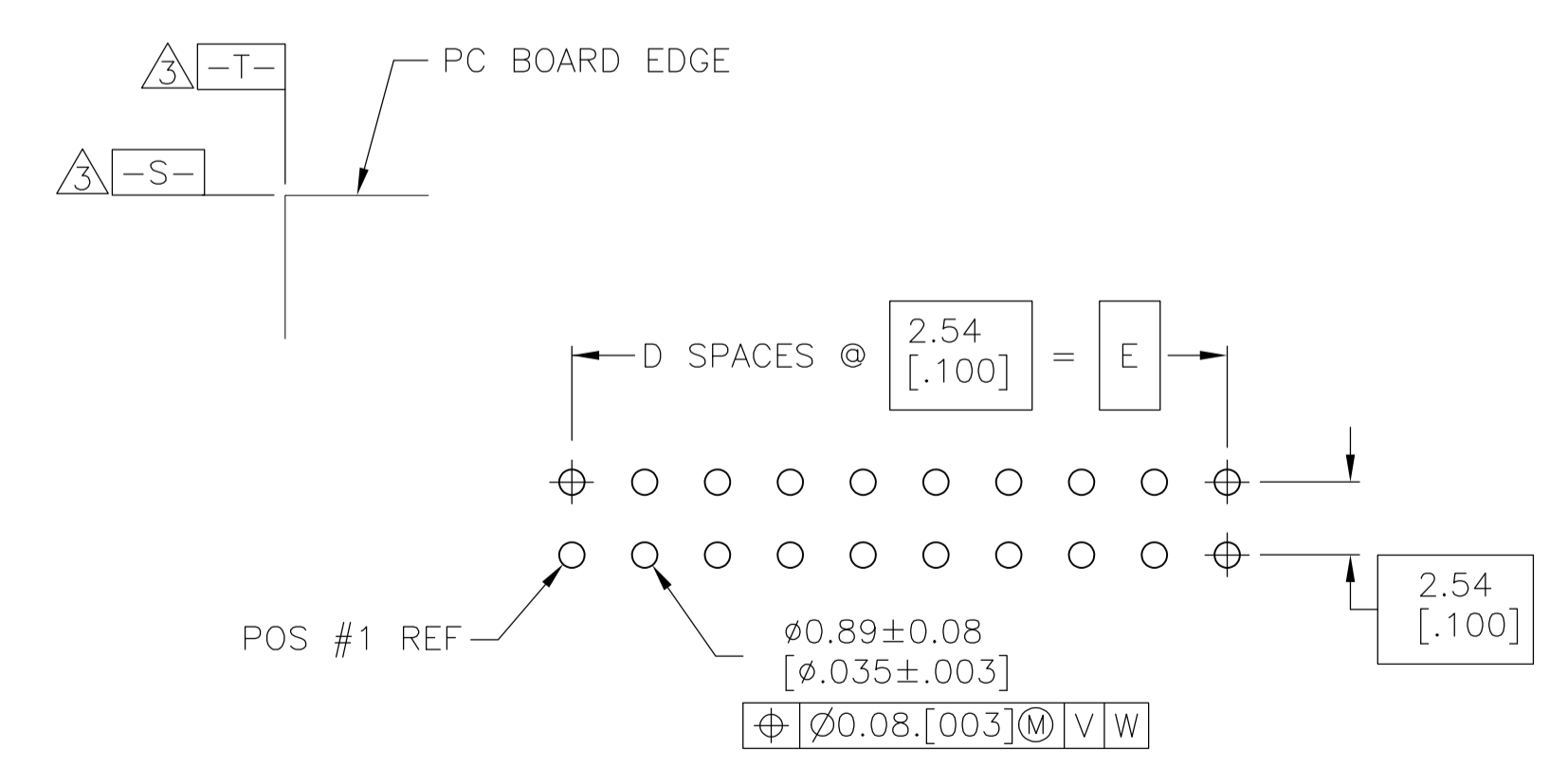
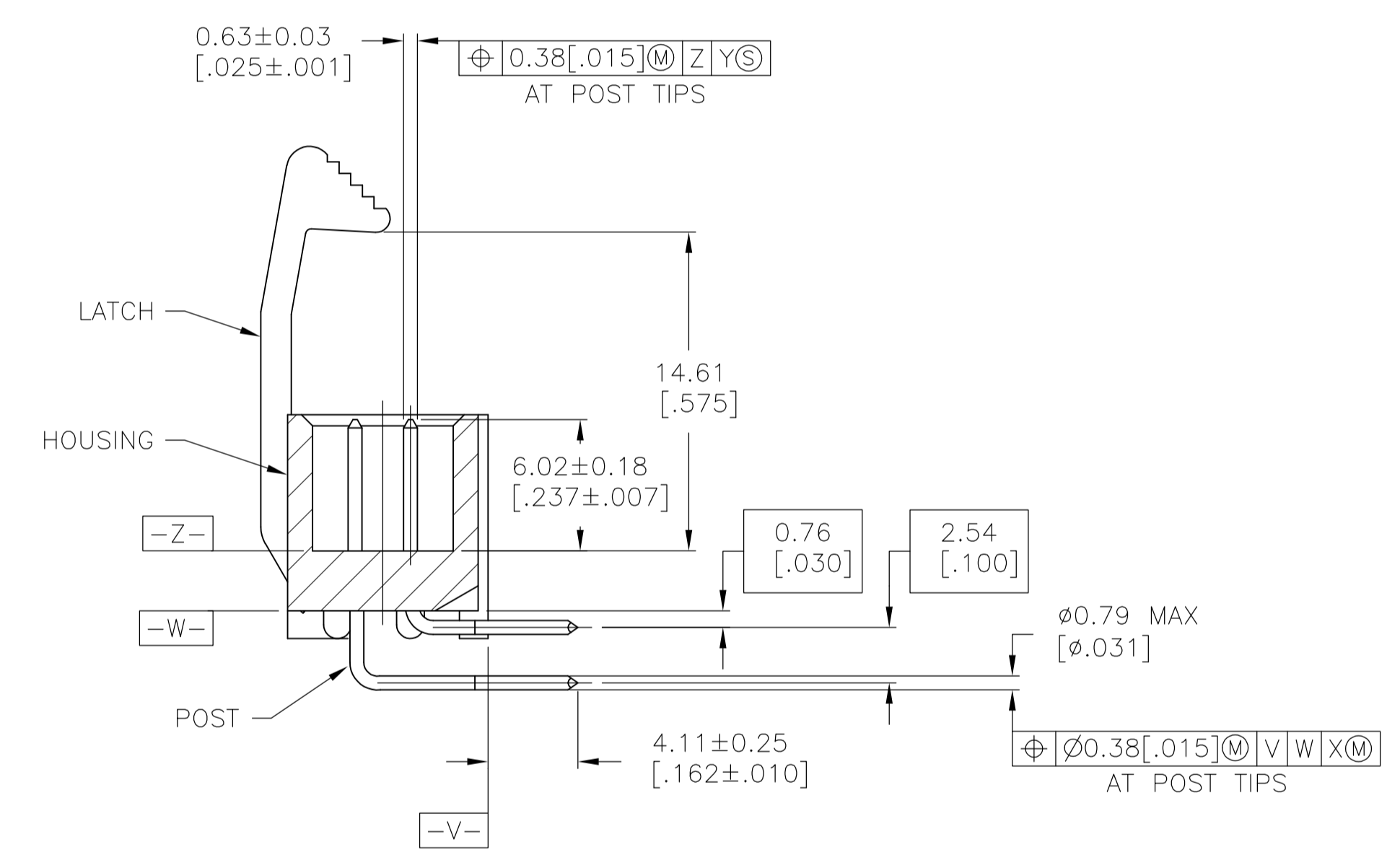
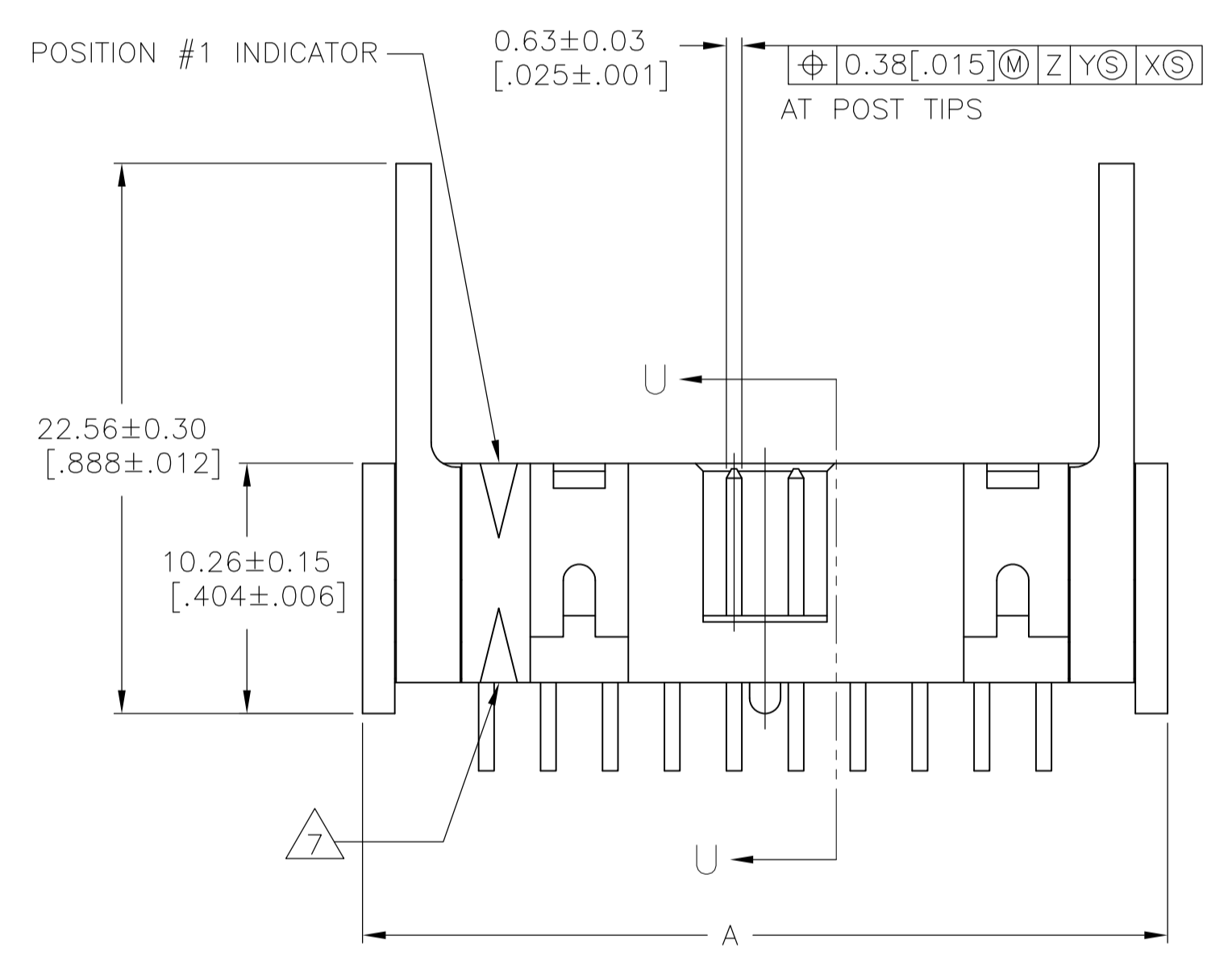

	E	D	C	B	A	NO OF POS	PART NUMBER
	73.66 [2.900]	29	75.69 [2.980]	81.18 [3.196]	83.82 [3.300]	60	3-1761712-6
	60.96 [2.400]	24	62.99 [2.480]	68.48 [2.696]	71.12 [2.800]	50	3-1761712-5
	48.26 [1.900]	19	50.29 [1.980]	55.78 [2.196]	58.42 [2.300]	40	3-1761712-3
OBSOLETE	40.64 [1.600]	16	42.67 [1.680]	48.16 [1.896]	50.80 [2.000]	34	3-1761712-1
	35.56 [1.400]	14	37.59 [1.480]	43.08 [1.696]	45.72 [1.800]	30	3-1761712-0
	30.48 [1.200]	12	32.51 [1.280]	38.00 [1.496]	40.64 [1.600]	26	2-1761712-9
	27.94 [1.100]	11	29.97 [1.180]	35.46 [1.396]	38.10 [1.500]	24	2-1761712-8
	22.86 [.900]	9	24.89 [.980]	30.38 [1.196]	33.02 [1.300]	20	2-1761712-7
OBSOLETE	17.78 [.700]	7	19.81 [.780]	25.30 [.996]	27.94 [1.100]	16	2-1761712-6
	15.24 [.600]	6	17.27 [.680]	22.76 [.896]	25.40 [1.000]	14	2-1761712-5
OBSOLETE	12.70 [.500]	5	14.73 [.580]	20.22 [.796]	22.86 [.900]	12	2-1761712-4
	10.16 [.400]	4	12.19 [.480]	17.68 [.696]	20.32 [.800]	10	2-1761712-3
	E	D	C	B	A	NO OF POS	PART NUMBER

THIS DRAWING IS A CONTROLLED DOCUMENT. DIMENSIONS: mm [INCHES]. TOLERANCES UNLESS OTHERWISE SPECIFIED: 0 PLC ±, 1 PLC ±, 2 PLC ±, 3 PLC ± 0.1% (.005), 4 PLC ±, ANGLES ±.

DIN B. CRISAMORE/DJI, S. BOLASH, M. WALMSLEY. Tyco Electronics Corporation, Harrisburg, PA 17105-3608. NAME: HEADER ASSEMBLY, LONG EJECT LATCH, RIGHT ANGLE, LOW PROFILE, IDC. APPLICATION SPEC: A1 00779. SIZE: A1. WEIGHT: -. SCALE: 4:1. SHEET: 1 OF 1. REV: E.

单击下面可查看定价，库存，交付和生命周期等信息

[>>TE Connectivity\(泰科\)](#)