

LOC	DIST	P	F	ZONE	LTR	REVISIONS	DATE	APPD
G	14					D REVISED PER 0720-0513-95	27MAR95	NRB

**METRIC**  
 DIMENSIONS LISTED IN mm [ INCHES ]

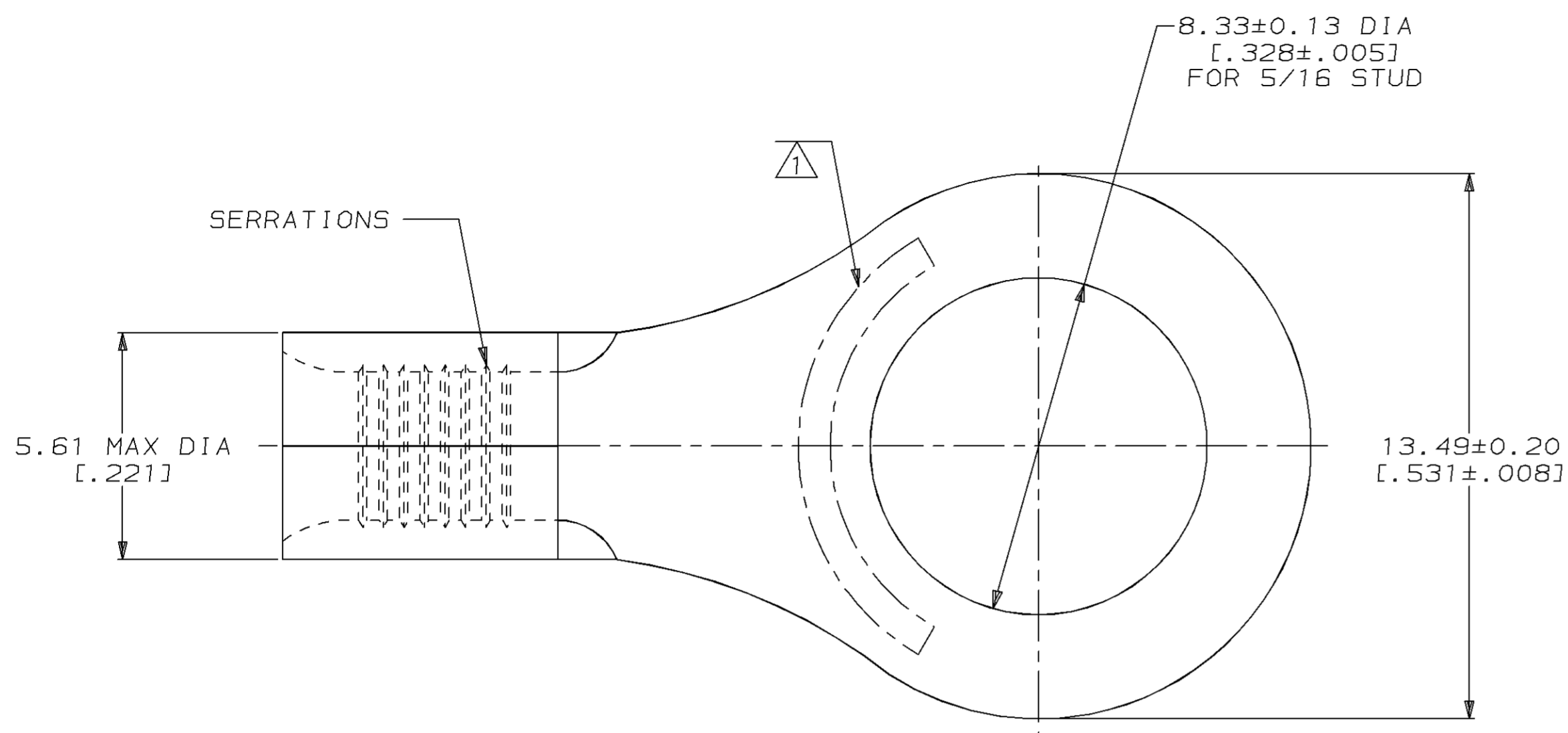

<b>AMP</b> WIRE RANGE	<b>UL</b> E13288 Listed
12-10 AWG STRANDED	12-10 AWG STRANDED
<b>SR</b> LR7189 Certified	MILITARY P/N AND CLASS
NOT CERTIFIED	NOT APPLICABLE

- ① STAMP AMP 12-10\* APPROX AS SHOWN
- ② TIN PL 0.00254 [.000100] MIN THK PER MIL-T-10727
- ③ GOLD PLATE 0.00127 [.000050] MIN EXT THK PER MIL-G-45204 OVER NICKEL PLATE 0.00076 [.000030] MIN EXT THK PER QQ-C-290

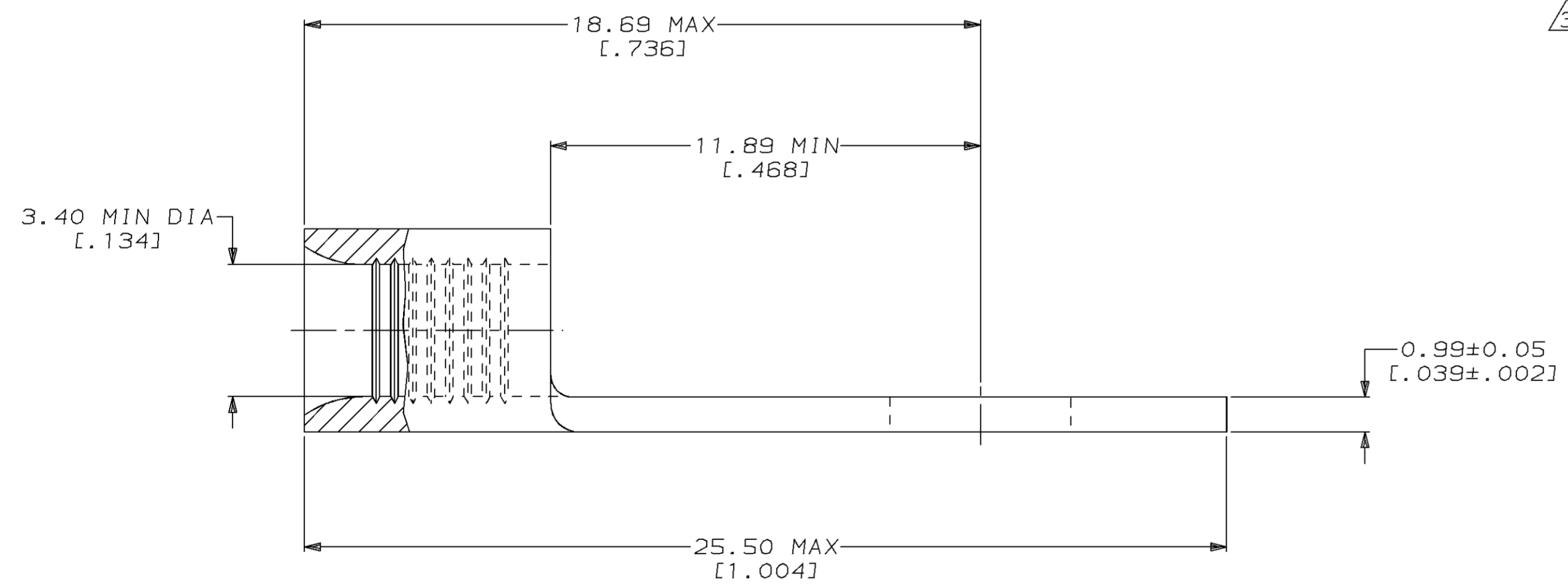

③	2-31123-2
②	31123
FINISH	PART NO

**AMP INCORPORATED**  
**CUSTOMER SERVICE SYSTEMS**

FOR ADDITIONAL PRODUCT INFORMATION OR COPIES OF DRAWINGS AND TECHNICAL DOCUMENTS	PRODUCT INFORMATION CENTER 1-800-522-6752
FOR APPLICATION TOOLING INFORMATION	TOOLING ASSISTANCE CENTER 1-800-722-1111
FOR ORDER ENTRY	1-800-526-5142

MAX RECOMMENDED OPERATING TEMPERATURE:  
 170°C MAX

VOLTAGE RATING:  
 NOT APPLICABLE

WIRE CROSS SECTIONAL AREA RANGE:  
 2.62-6.64mm<sup>2</sup> [5,180-13,100] CIR MILS  
 STRANDED

THIS DRAWING IS A CONTROLLED DOCUMENT FOR AMP INCORPORATED. IT IS SUBJECT TO CHANGE AND THE CONTROLLING ENGINEERING ORGANIZATION SHOULD BE CONTACTED FOR THE LATEST REVISION.

DO NOT SCALE PRINT. UNLESS SPECIFIED DIMENSIONS IN mm [INCHES]— TOLERANCES ON : 2 PLC DEC ± - 3 PLC DEC ± - ANGLES ± -	DR 2-9-93 TA BRINKMAN
MATERIAL COPPER PER ASTM B-152 ANNEALED	CHK 2-9-93 DA PATTERSON
FINISH SEE TABLE	APPD 2-9-93 DE MILLER
	APPD 2-9-93 JL MECKLEY
	PRODUCT SPEC -
	APPLICATION SPEC -
	WEIGHT -

<b>AMP</b> AMP Incorporated Harrisburg, PA 17105-3608		
NAME TERMINAL, RING TONGUE, BUDGET		
SIZE C	CAGE CODE 00779	DRAWING NO G=31123
SCALE 8:1		SHEET 1 OF 1

单击下面可查看定价，库存，交付和生命周期等信息

[>>TE Connectivity\(泰科\)](#)