

REVISIONS

P	LTR	DESCRIPTION	DATE	DWN	APVD
	B	REVISED PER ECO-19-009164	23JUN2020	SJ	DR

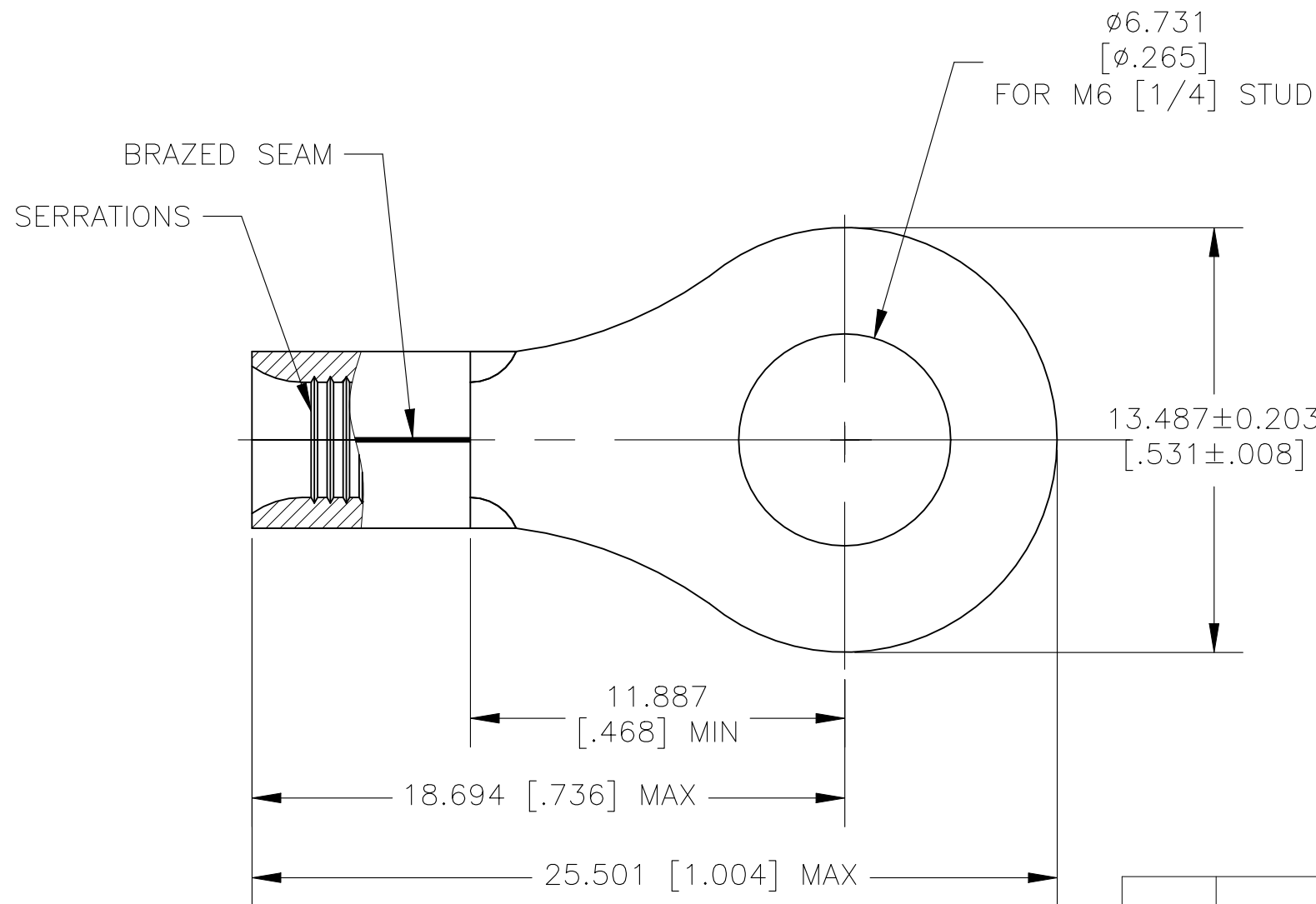

1. WIRE RANGE: 12-10 AWG. STANDARD
WIRE CROSS SECTIONAL AREA RANGE:
5,180-13,100 CIRCULAR MILS, STRANDED

2. TERMINAL BODY MATERIAL THK IS
0.990±0.076[.039±.003]

3. RECOMMENDED OPERATING TEMP -55°C(-67°F) TO
+200°C(392°F) FOR HEAT SHRINK TUBING.

4. HEAT SHRINK TUBING SHELF LIFE OF 18 MONTHS
FROM DATE CODE ON LABEL.

△ 5 TERMINAL BODY PRODUCT SPECIFICATION 108-32046.
APPLICATION SPECIFICATION 114-2162.

1	2-1197130-7	HIGH AND LOW TEMPERATURE CROSS LINKED FLUOROPOLYMER HEAT SHRINK TUBING 6.35 [.250] MIN ID X 25.40±2.03 [1.000±.080], RT-555-1/4-0-SP
1	323063	TERMINAL BODY: COPPER PER ASTM B152 ANNEALED FINISH: NICKEL PLATE 0.00762 [.000300] MIN EXT THK PER SAE AMS QQ-N-290
-1	PART NO	DESCRIPTION

THIS DRAWING IS A CONTROLLED DOCUMENT.		DWN JR RUTH 22JAN09	STE TE Connectivity	
DIMENSIONS: MM [INCHES]		CHK TOM MICHIELUTTI 22JAN09		
TOLERANCES UNLESS OTHERWISE SPECIFIED:		APVD TOM MICHIELUTTI 22JAN09	NAME HEAT RESISTANT TERMINAL KIT WIRE SIZE: 12-10 AWG	
0 PLC ± -		PRODUCT SPEC	SIZE	
1 PLC ± -		△ 5	CAGE CODE	
2 PLC ± -		APPLICATION SPEC	DRAWING NO	
3 PLC ± 0.127 [.005]		△ 5	RESTRICTED TO	
4 PLC ± -		WEIGHT	A300779 C-1958292	
ANGLES ± 1°		CUSTOMER DRAWING		
MATERIAL SEE TABLE		SCALE 1:1		
FINISH SEE TABLE		SHEET 1 OF 1		
		REV B		

单击下面可查看定价，库存，交付和生命周期等信息

[>>TE Connectivity\(泰科\)](#)