

LOC		DIST		REVISIONS			
P	LTR	DESCRIPTION	DATE	DN	APVD		
G		REVISED PER ECO-09-024765	14JAN2010	CR	SB		

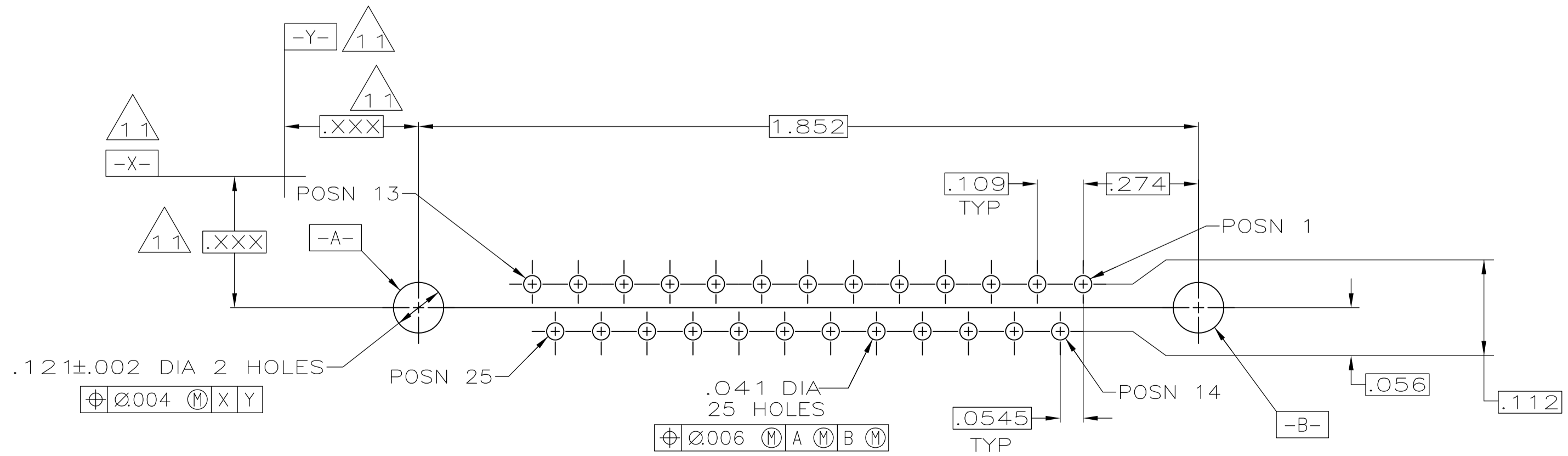
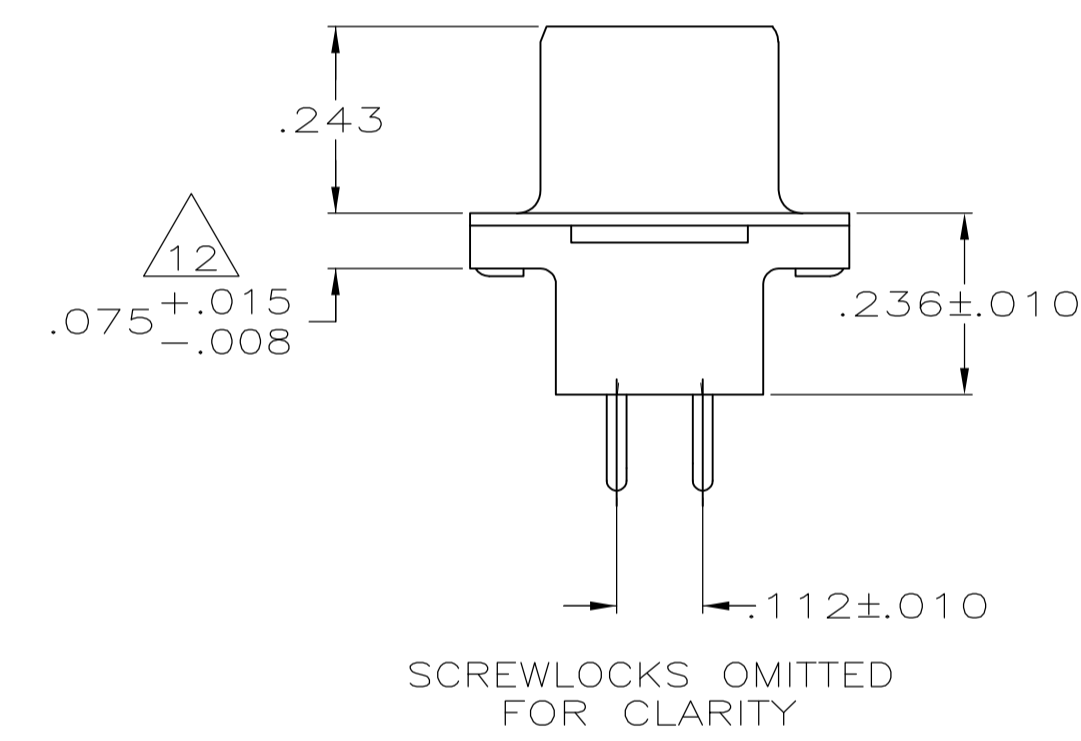
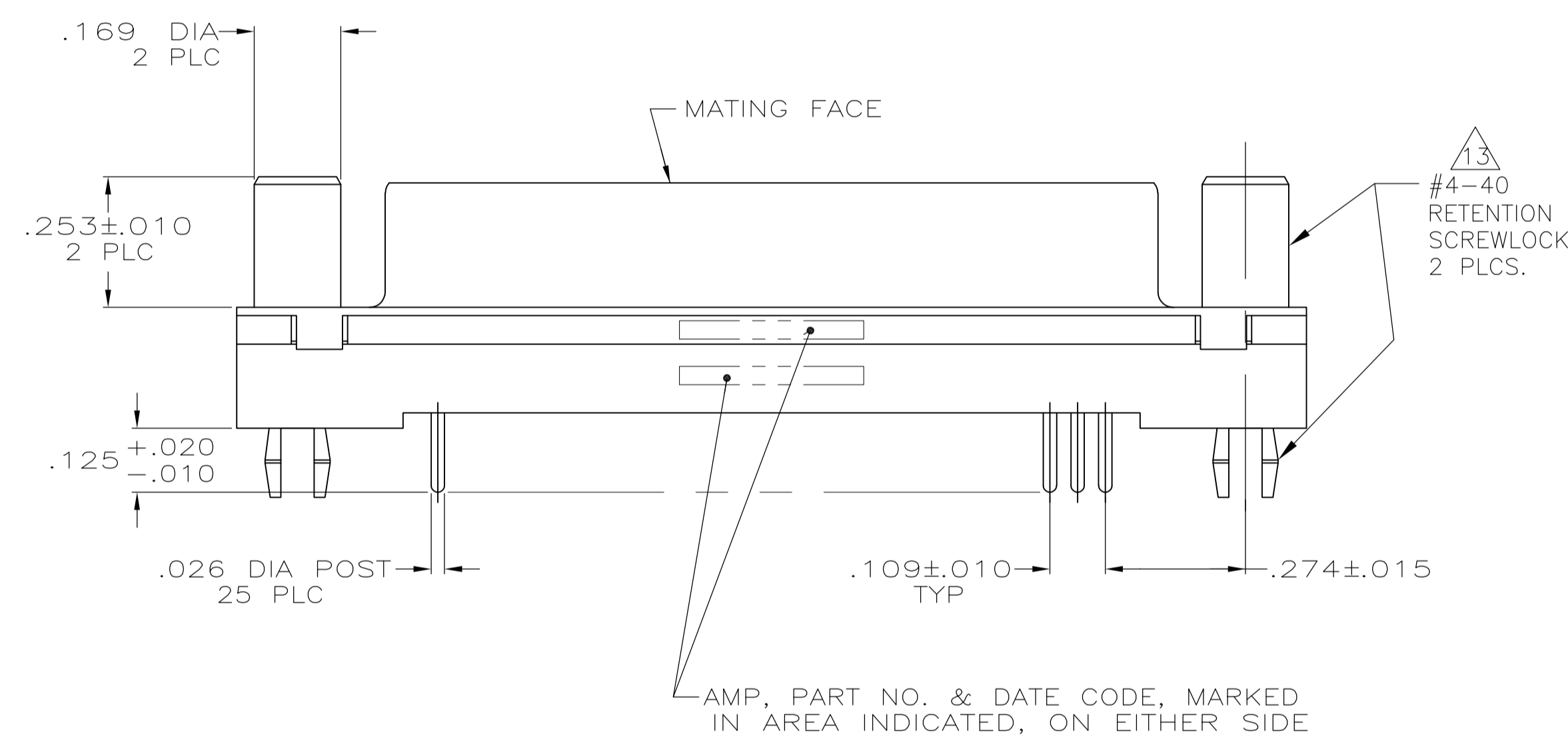
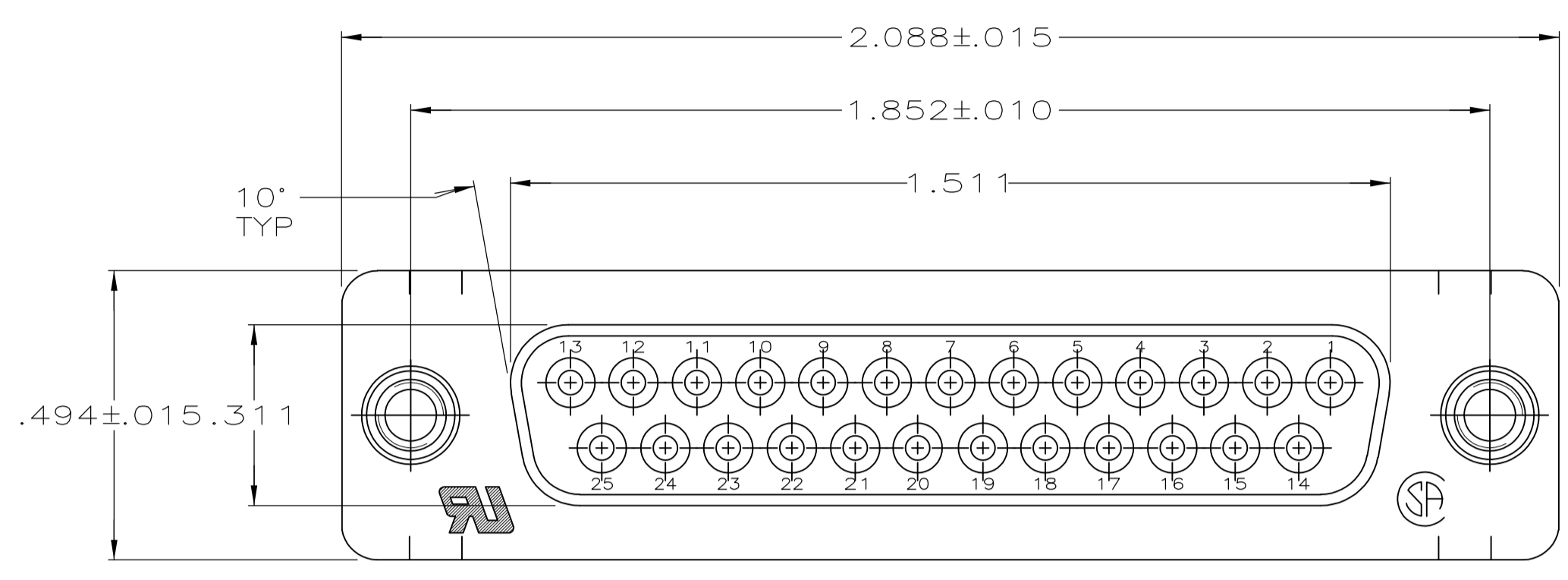

PC BOARD MOUNTING DIMENSIONS  
 CONNECTOR SIDE OF BOARD  
 .062 PC BOARD THICKNESS

1. NOTE DELETED.
2. HOUSING: FLAME RETARDANT 94V-0 RATED, GLASS FILLED, NYLON OR POLYESTER, COLOR: BLACK.
3. SHELL: CARBON STEEL.
4. CONTACT: PHOS. BRONZE.
5. RETENTION SCREWLOCK: BRASS.
6. NOTE DELETED.
7. SHELL: .000200 MIN TIN OVER .000100 MIN COPPER.
8. RETENTION SCREWLOCK: .000100 MIN TIN-LEAD OVER .000050 MIN NICKEL OVER COPPER FLASH.
9. CONTACT: PLATED WITH .000030 GOLD FOR LENGTH OF .100 MIN FROM MATING END, WITH POINT OF MEASUREMENT .050 FROM MATING END OF CONTACT, .000100-.000200 TIN OR TIN LEAD ON SOLDER END, ALL OVER .000050 NICKEL ON ENTIRE CONTACT.
10. NOTE DELETED.
11. DATUMS AND BASIC DIMENSIONS ESTABLISHED BY CUSTOMER.
12. .110 MAX IN SHELL TAB CLINCH AREAS.
13. ORIENTATION IS OPTIONAL AND MAY NOT BE AS SHOWN.

748612-1  
 PART NUMBER

THIS DRAWING IS A CONTROLLED DOCUMENT.		DIN C. RICHARD 1-5-88	Tyco Electronics Corporation Harrisburg, PA 17105-3608	
DIMENSIONS: INCHES		CHK W. LENKER 1-6-88	NAME	
TOLERANCES UNLESS OTHERWISE SPECIFIED:		PRODUCT SPEC		
0 PLC ± -		108-40025		
1 PLC ± -		APPLICATION SPEC		
2 PLC ± -		114-40023		
3 PLC ± .005		SIZE		
4 PLC ± -		CAGE CODE		
ANGLES ± -		DRAWING NO		
MATERIAL		WEIGHT		
FINISH		A1 00779 C=748612		
CUSTOMER DRAWING		SCALE 4:1 SHEET 1 OF 1 REV G		

单击下面可查看定价，库存，交付和生命周期等信息

[>>TE Connectivity\(泰科\)](#)