

THIS DRAWING IS UNPUBLISHED. RELEASED FOR PUBLICATION
 © COPYRIGHT - By - ALL RIGHTS RESERVED.

LOC	DIST	REVISIONS			
P	LTR	DESCRIPTION	DATE	DWN	APVD
G	50	C	ECR-13-000998	11FEB2013	PK HS

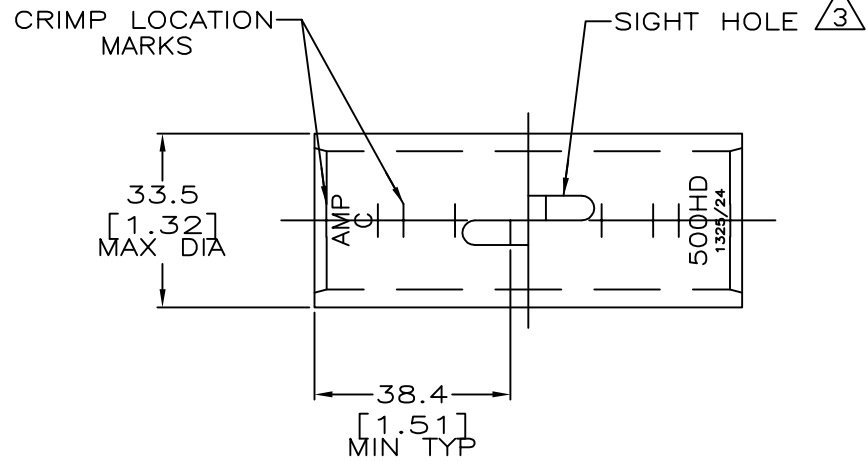

- 1 CIRCULAR MIL RANGE: 450-550 MCM
- 2 USE CRIMP DIES 46756-2 (600 MCM)

$\triangle 3$.045 MAX BURR ALLOWED INSIDE THE WIRE BARREL ID IN AREA OF SIGHT HOLE.

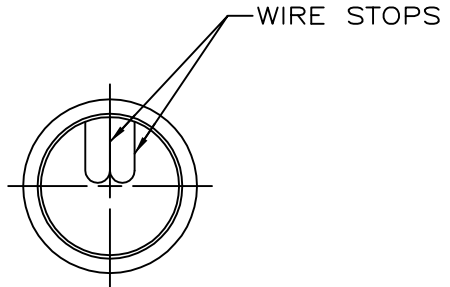
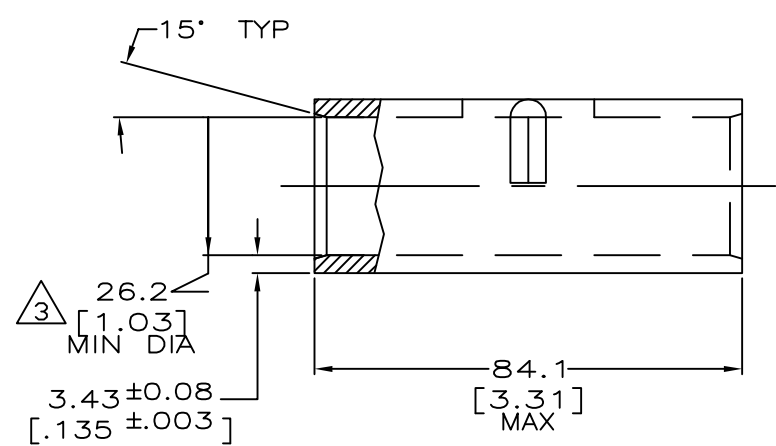

696058-1
PART NUMBER

THIS DRAWING IS A CONTROLLED DOCUMENT.		DWN JR RUTH 28DEC98			NAME			
DIMENSIONS: mm		CHK M BRENNEMAN 28DEC98			SPLICE, BUTT, HEAVY DUTY, AMPOWER, WIRE SIZE: 500 MCM			
TOLERANCES UNLESS OTHERWISE SPECIFIED:		APVD JL MECKLEY 28DEC98			PRODUCT SPEC	108-30200-3	RESTRICTED TO	
0 PLC ± - 1 PLC ± - 2 PLC ± 0.20[.008] 3 PLC ± - 4 PLC ± - ANGLES ± 5°		APPLICATION SPEC			SIZE	CAGE CODE	DRAWING NO	
MATERIAL COPPER	FINISH TIN PLATE	WEIGHT 242 grams	A3	HS	C=696058	SCALE 1:1	SHEET 1 OF 1	REV C
CUSTOMER DRAWING								

单击下面可查看定价，库存，交付和生命周期等信息

[>>TE Connectivity\(泰科\)](#)