

THIS DRAWING IS UNPUBLISHED. RELEASED FOR PUBLICATION, 19
 © COPYRIGHT 19 BY AMP INCORPORATED. ALL INTERNATIONAL RIGHTS RESERVED.

LOC	DIST	P	F	REVISIONS				
AF	50			ZONE	LTR	DESCRIPTION	DATE	APPD
					B	RELEASED PER FASR AND 0L10-0061-96	29/AUG/96	PF/GY

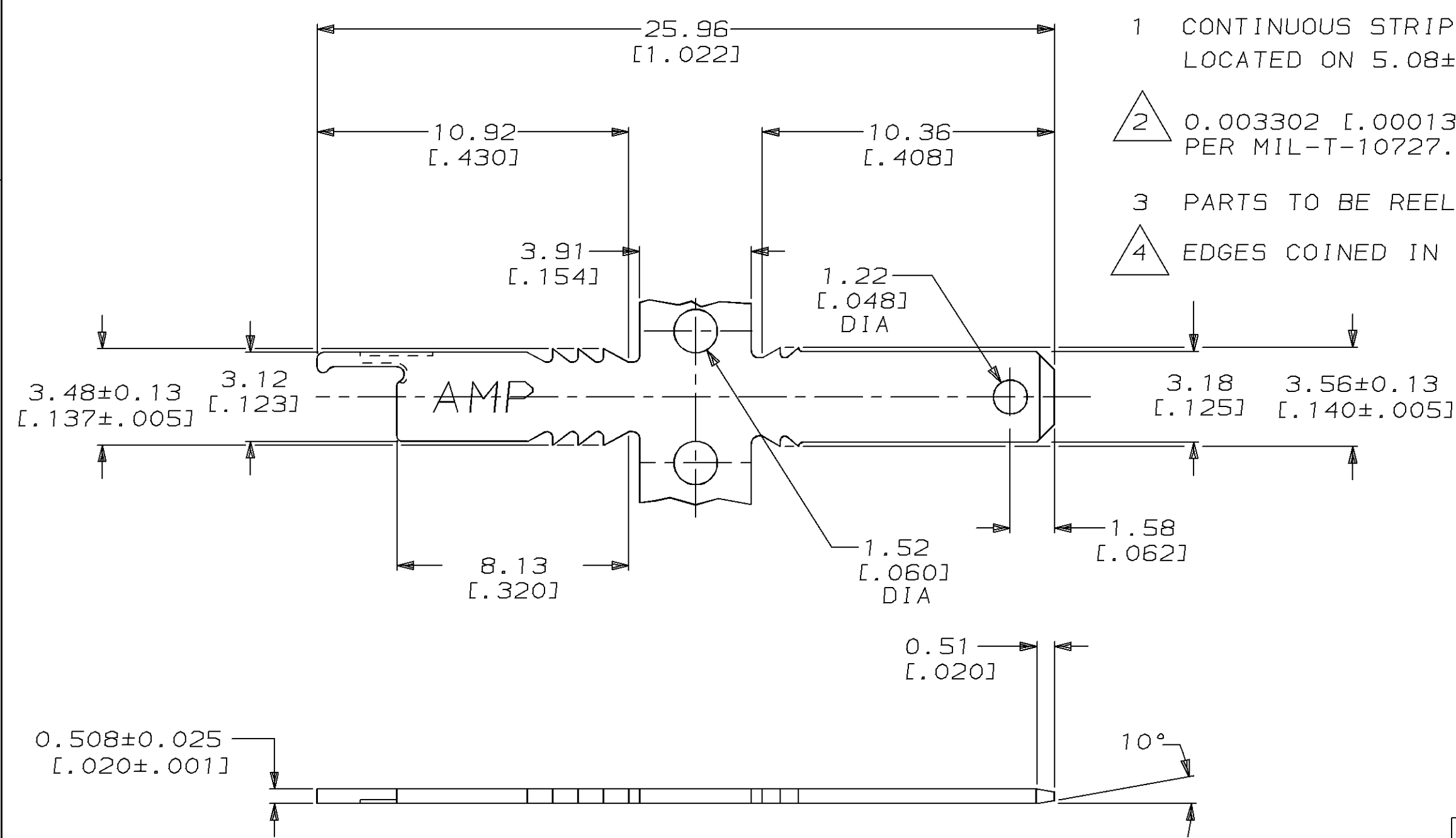

- 1 CONTINUOUS STRIP ON REEL WITH TERMINALS LOCATED ON 5.08±0.08 [.200±.003] CENTERS.
- 2 0.003302 [.000130] MAX PRE-TIN PLATE PER MIL-T-10727.
- 3 PARTS TO BE REELED WITH PAPER.
- 4 EDGES COINED IN THIS AREA TO REMOVE BURRS.

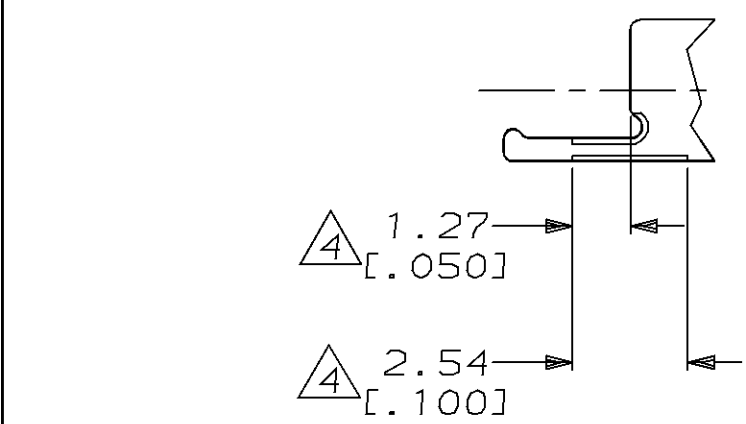

THIS DRAWING IS A CONTROLLED DOCUMENT FOR AMP INCORPORATED. IT IS SUBJECT TO CHANGE AND THE CONTROLLING ENGINEERING ORGANIZATION SHOULD BE CONTACTED FOR THE LATEST REVISION.

DO NOT SCALE PRINT, UNLESS SPECIFIED DIMENSIONS IN mm [INCHES] TOLERANCES ON: 2 PLC DEC ± 0.25 [.010] 3 PLC DEC ± - ANGLES ± -	DR	28/FEB/96 PHILLIP M FORTNEY
	CHK	28/FEB/96 JEFF R RUTH
	APPD	28/FEB/96 GARY YETTER
	APPD	28/FEB/96 MARK BARNABA
MATERIAL	082 BRASS	
FINISH	SEE TABLE	
	APPLICATION SPEC	-
	WEIGHT	-

FINISH		PART NO	
AMP		AMP Incorporated Harrisburg, PA 17105-3608	
NAME			
BOBBIN TAB			
SIZE	CAGE CODE	DRAWING NO	
B	00779	C-63917	
SCALE	6:1	SHEET	1 OF 1

单击下面可查看定价，库存，交付和生命周期等信息

[>>TE Connectivity\(泰科\)](#)