

THIS DRAWING IS UNPUBLISHED. RELEASED FOR PUBLICATION
 © COPYRIGHT - By - ALL RIGHTS RESERVED.

LOC	DIST	REVISIONS					
		P	LTR	DESCRIPTION	DATE	DWN	APVD
G	01	A2		ECR-13-016672	25OCT13	PKS	RRP

- CONTINUOUS STRIP ON REELS WITH TERMINALS LOCATED ON 5.59 ± 0.08 [.220 ± .003] CENTERS
- SLOT TERMINATES EITHER A SINGLE OR DOUBLE MAGNET WIRE OF THE SAME SIZE AND TYPE. COPPER RANGE: 0.16-0.18mm [#34-#33]
- POKE-IN ACCEPTS A $0.5-0.9\text{mm}^2$ [#20#18] AWG SOLID OR FUSED STRANDED LEAD WIRE.

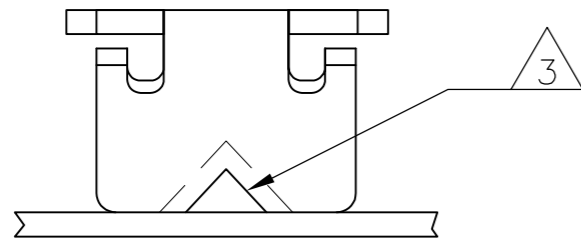

IDENTIFICATION NUMBER 3 FOR MAGNET WIRE RANGE

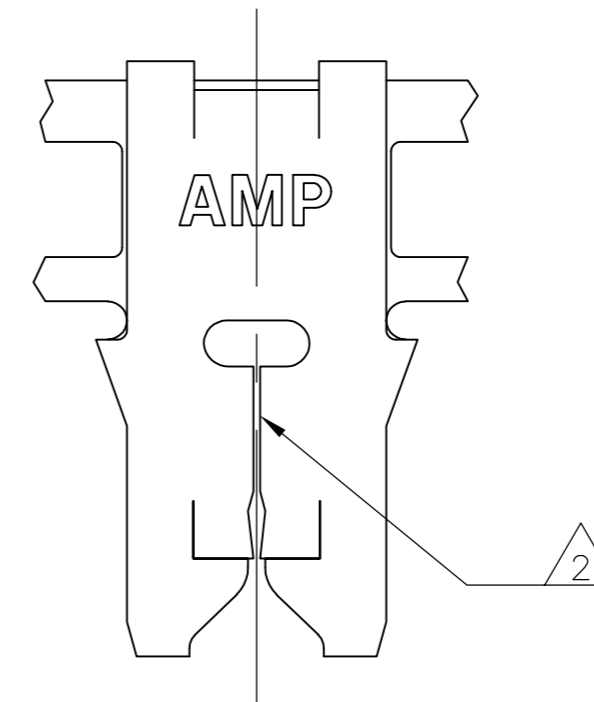
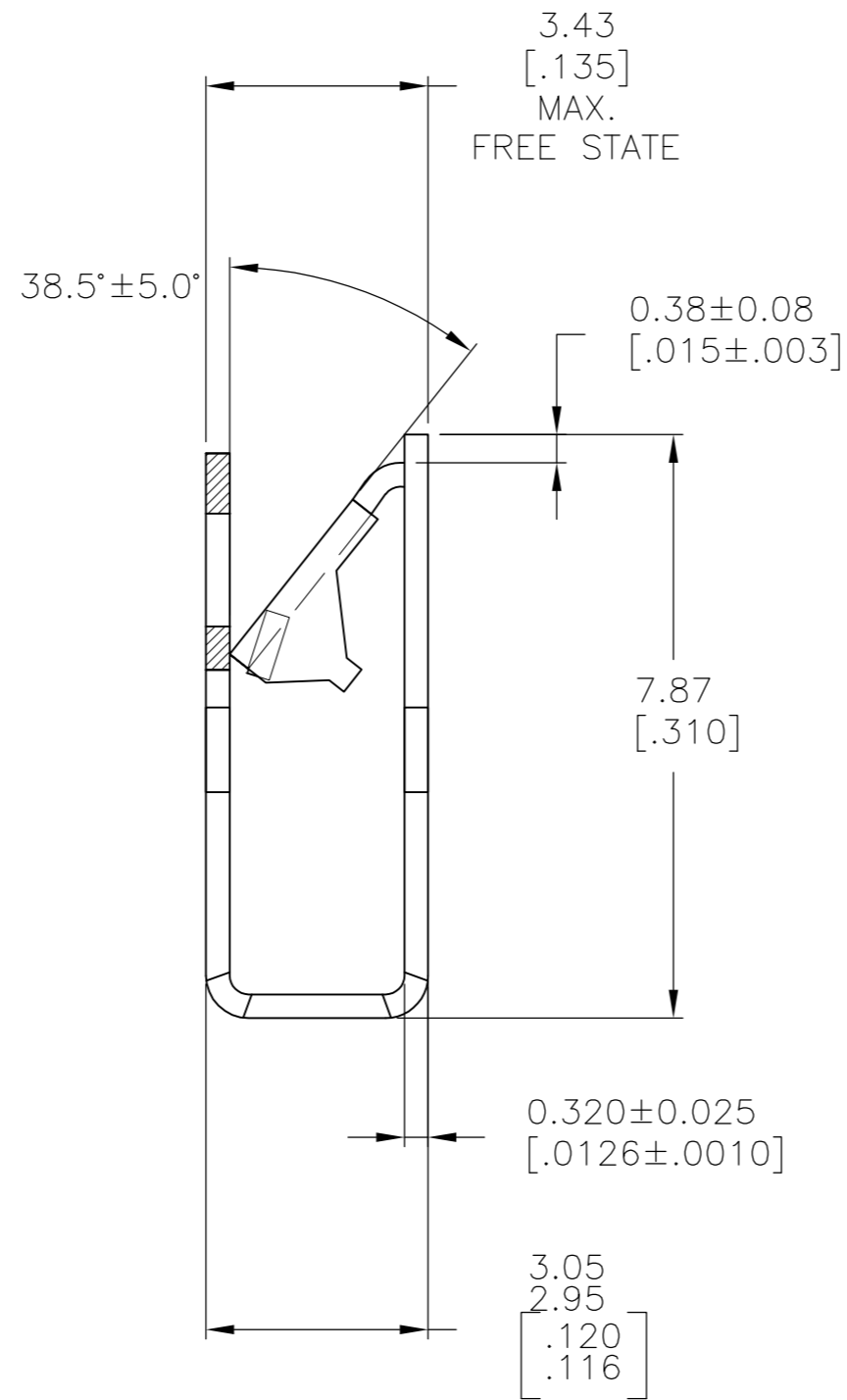
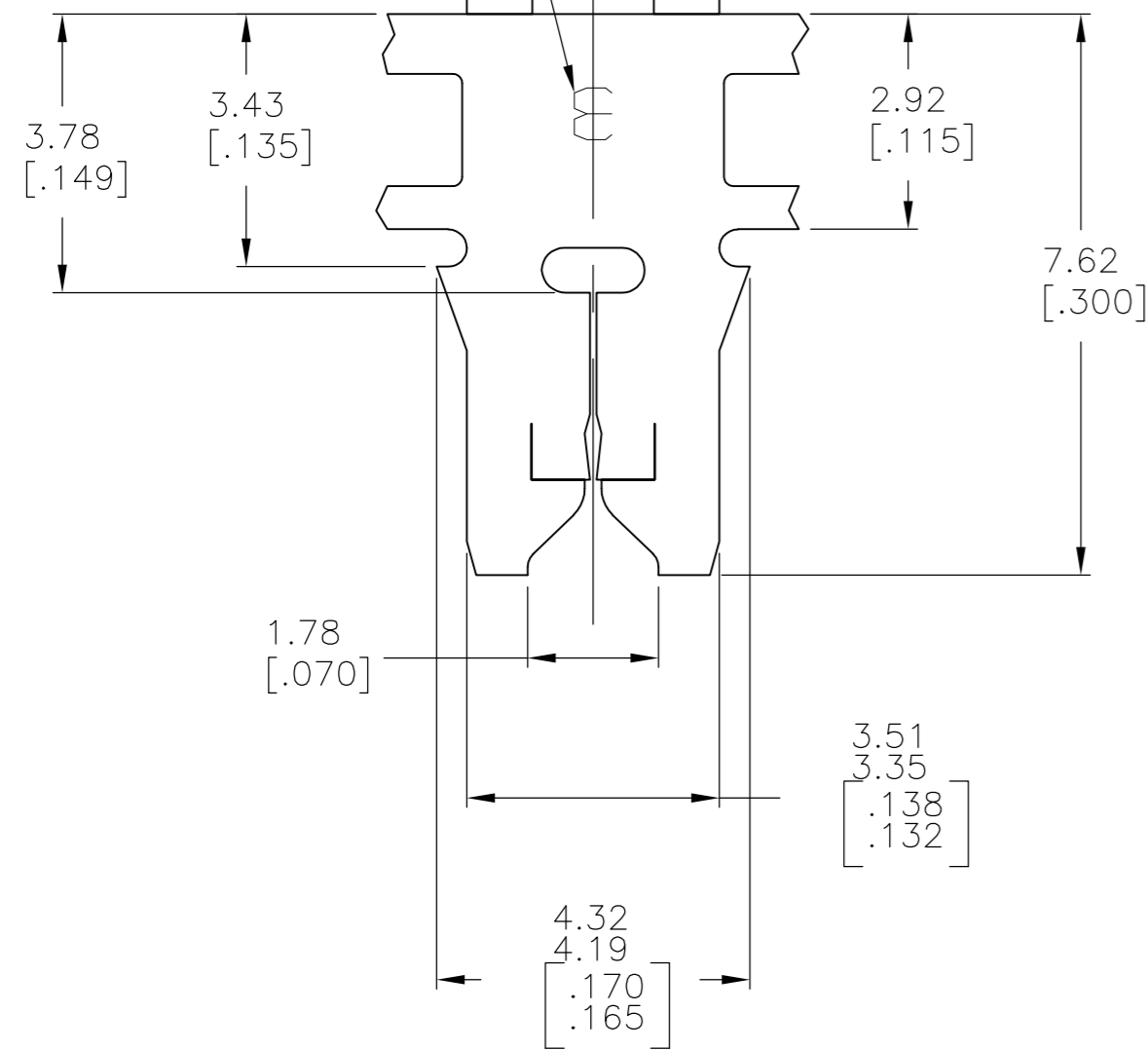

1742379-1
PART NUMBER

THIS DRAWING IS A CONTROLLED DOCUMENT.		DWN M.S. FEHER 16JAN2006	TE TE Connectivity	
DIMENSIONS: mm [INCHES]		CHK K.A. RANDOLPH 16JAN2006		
TOLERANCES UNLESS OTHERWISE SPECIFIED:		APVD K.A. RANDOLPH 16JAN2006	NAME	
0 PLC ± -		PRODUCT SPEC	TERMINAL, POKE-IN	
1 PLC ± -		108-2012	300 SERIES MAG-MATE	
2 PLC ± 0.25[.010]		APPLICATION SPEC	SIZE	CAGE CODE
3 PLC ± -		114-2046	A2	00779
4 PLC ± -		WEIGHT -	DRAWING NO	RESTRICTED TO
ANGLES ± -		CUSTOMER DRAWING	C=1742379	-
MATERIAL BRASS	FINISH TIN PLATE	SCALE 10:1	SHEET 1 of 1	REV A2

单击下面可查看定价，库存，交付和生命周期等信息

[>>TE Connectivity\(泰科\)](#)