

©1961 BY AMP INCORPORATED. ALL RIGHTS RESERVED. AMP PRODUCTS COVERED BY PATENTS AND/OR PATENTS PENDING.

REVISIONS				
ZONE	LTR	DESCRIPTION	DATE	APPROVED
	L	REDRAWN WITHOUT CHANGE W-868	9-24-5	m.s./d.h
	M	OBS-6.7 ECN OF 0949	2A 11-88	JW
	N	REV. Per. 063D-54A-02	CT 12-03	CT
	P	ECO-10-020499	PY 15FEB11	DE

NUMBER 66086

MAX. EXTENSION BEYOND BACK FACE OF BLOCK.

BACK FACE OF BLOCK.

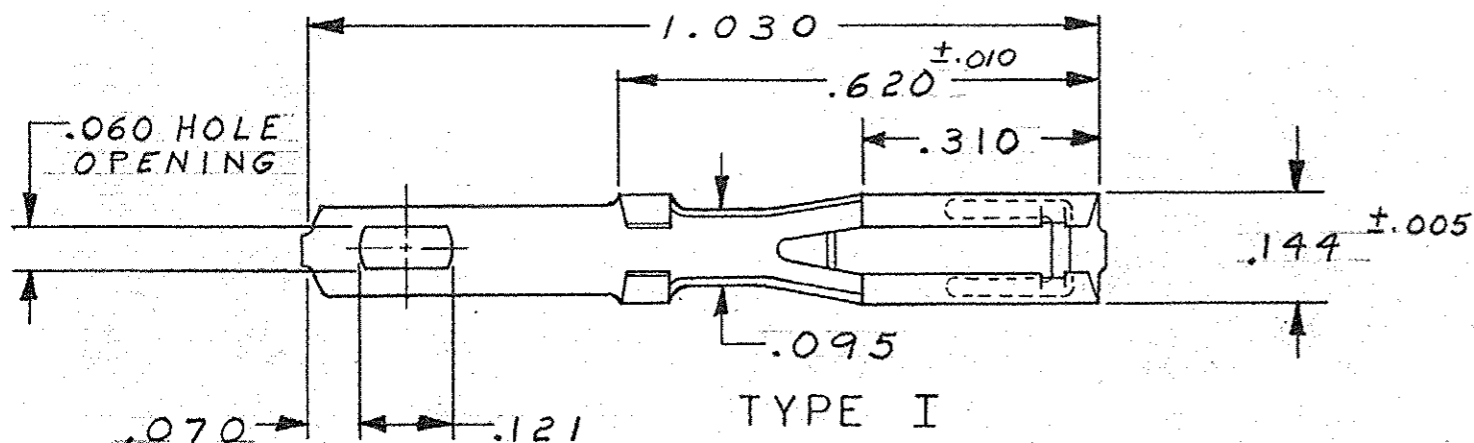

TYPE I

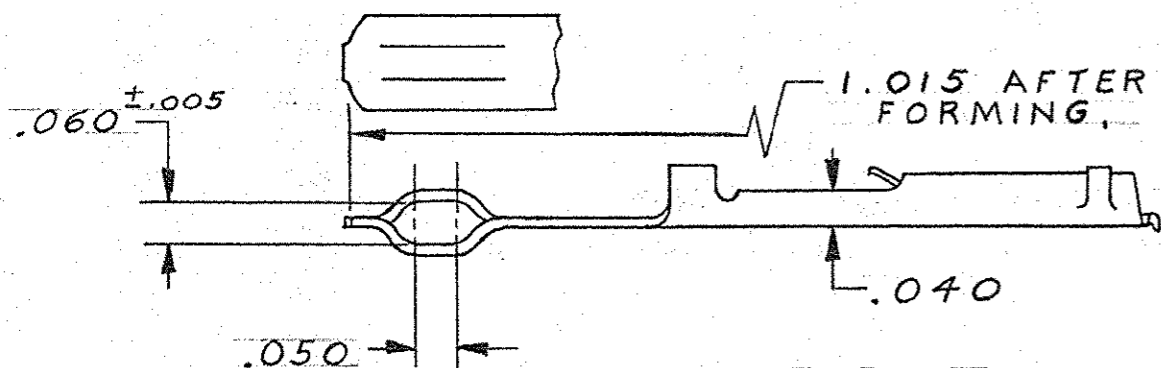

TYPE II

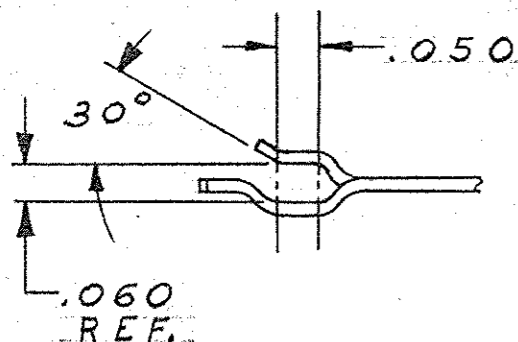
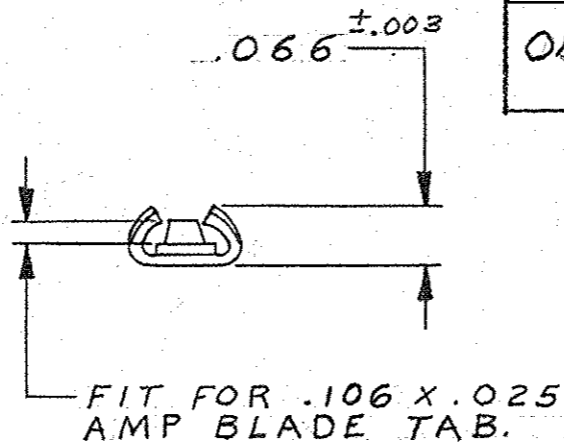

TYPE III

TERMINAL NUMBER	A	TYPE	FINISH
66086-2	.390	I	GOLD
OBS	-3	II	
OBS	-4	III	
	-5	I	
	-6	II	
OBS	66086-7	.375	III

NOTE:

1. FOR SUPPLEMENTAL SPECIFICATIONS SEE E. S. 8-1-3.

UNLESS OTHERWISE SPECIFIED DIM. ARE IN INCHES. TOLERANCES ON: DECIMALS ±.015 ANGLES ± 0°30'		CONTRACT NO. 9-23-65		AMP INCORPORATED HARRISBURG, PENNSYLVANIA	
MATERIAL PHOS. BRONZE		DR M. Smith		NAME AMP BLADE RECP. WITH SOLDER TAB	
HEAT TREAT #		CHK S.S. Heide 11/3/65		SIZE B	
FINISH SEE TABLE		APPD E. Mendon 11/3/65		CODE IDENT NO. 00779	
LOC PRINT DIST DF (M) HO		DSGR APPD R. Holleyday 11/3/65		NUMBER 66086	
		OTHER APPD		REV P	
				SCALE 4-1	
				WT CALC ACTUAL SHEET 1 OF 1	

单击下面可查看定价，库存，交付和生命周期等信息

[>>TE Connectivity\(泰科\)](#)