

THIS DRAWING IS UNPUBLISHED. RELEASED FOR PUBLICATION  
 © COPYRIGHT BY TYCO ELECTRONICS CORPORATION. ALL RIGHTS RESERVED.

LOC	DIST	REVISIONS			
P	LTR	DESCRIPTION	DATE	DWN	APVD
G	14	REV PER ECR 09-025674	30NOV09	JR	TM

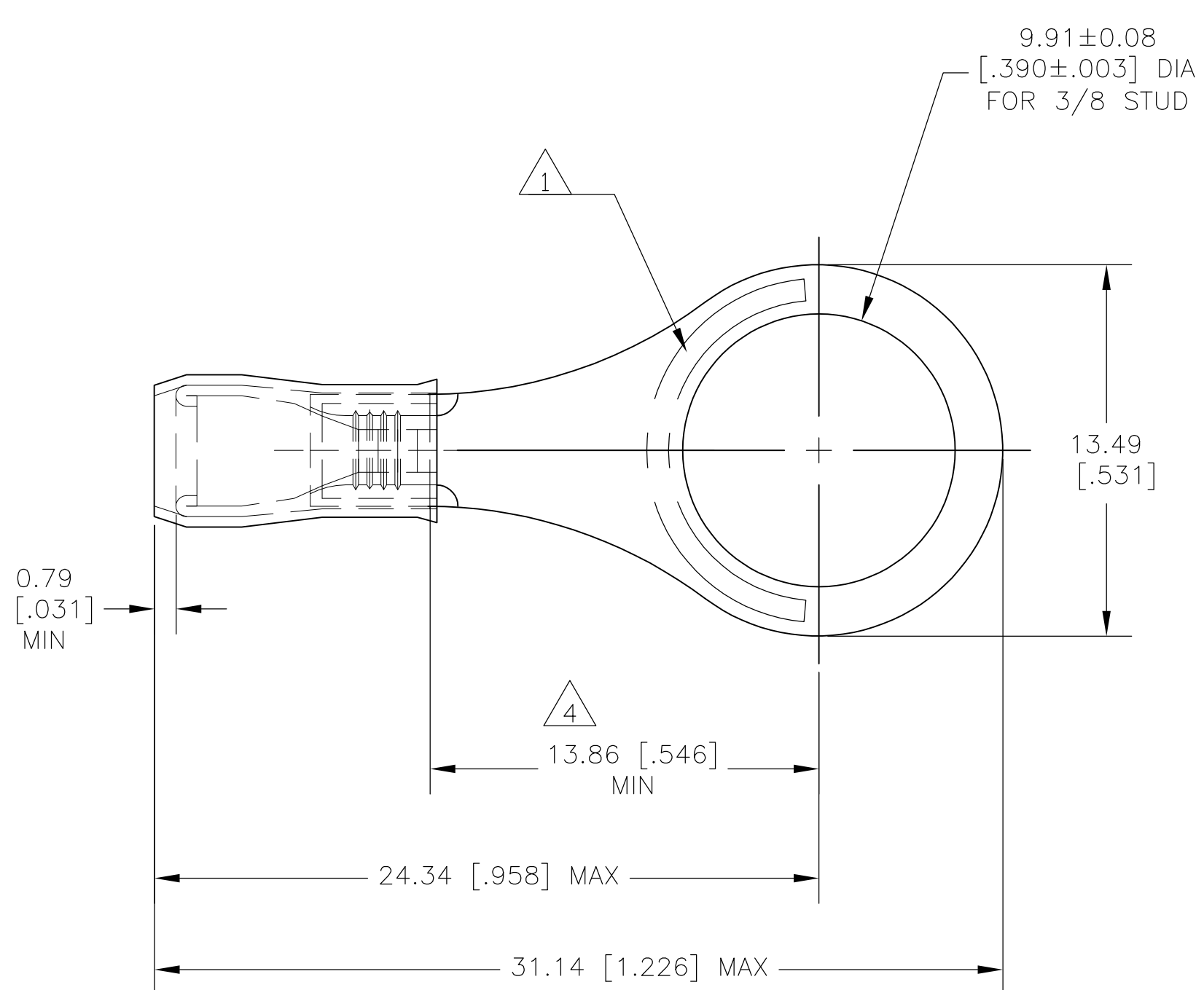

- 1 STAMP AMP 14-12, LOCATION AS SHOWN.
- 2 WIRE INSULATION DIA RANGE IS 2.0-3.2 [.080-.125] DIA.
- 3 TONGUE MATERIAL THK IS 0.75±0.05 [.0295±.002]
- 4 DIMENSION APPLIES FROM CENTER OF STUD HOLE TO EDGE OF WIRE BARREL.
- 5 MATERIAL: BODY - COPPER PER ASTM B-152 SLEEVE - NYLON, COLOR WHITE
- 6 FINISH: BODY - TIN PLATE PER ASTM B-545
- 7 MAX RECOMMENDED OPERATING TEMP 105°C
- 8 VOLTAGE RATING: 300 V MAX
- 9 WIRE CROSS SECTIONAL AREA RANGE: 1.65-3.45mm<sup>2</sup> [ 3,260-6,800 ] CMA

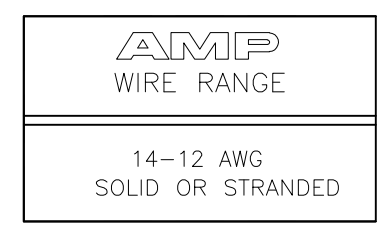

500	LOOSE PIECE	152869
QTY	PACKAGING TYPE	PART NO

THIS DRAWING IS A CONTROLLED DOCUMENT.		DWN jr_ruth 23AUG07	Tyco Electronics Corporation Harrisburg, PA 17105-3608	
DIMENSIONS: MM [ INCHES ]		CHK T MICHIELUTTI 23AUG07	NAME RING TONGUE, PIDG, WIRE SIZE: 14-12 AWG	
TOLERANCES UNLESS OTHERWISE SPECIFIED:		APVD T MICHIELUTTI 23AUG07	PRODUCT SPEC	
0 PLC ± -		APPLICATION SPEC		
1 PLC ± -		WEIGHT -		
2 PLC ± 0.20 [.008]		SIZE A3 CAGE CODE 00779 DRAWING NO C-152869		
3 PLC ± -		RESTRICTED TO -		
4 PLC ± -		SCALE 5:1 SHEET 1 OF 1 REV G		
ANGLES ± 5°		CUSTOMER DRAWING		
MATERIAL - 5	FINISH - 6			

单击下面可查看定价，库存，交付和生命周期等信息

[>>TE Connectivity\(泰科\)](#)