

.063	1.60	-	-
.050	1.27	-	-
.040	1.02	-	-
.035	0.89	22.000	558.80
.032	0.81	1.000	25.40
.025	0.64	.770	19.56
.020	0.51	.620	15.75
.015	0.38	.535	13.59
.010	0.25	.310	7.87
.008	0.20	.305	7.75
.005	0.13	.295	7.49
.001	0.03	.260	6.60
.000350	.00889	.225	5.72
.000150	.00381	.140	3.56
.000050	.00127	.130	3.30
.000030	.00076	.125	3.18
.000	0.00	.100	2.54
IN	MM	IN	MM

CONVERSION TABLE

TUBE LOADED HEADER ASSEMBLY NTS

- 1. POST TO WITHSTAND 13 NEWTONS (3LBS.) MIN. AXIAL FORCE IN BOTH DIRECTIONS SHOWN WITHOUT DISLODGING.
- 2. TOLERANCES APPLY TO SOLDER SIDE OF BOARD.
- 3. MEASURED AT SURFACE $\overline{A-A}$
- 4. PLASTIC FLASH PERMITTED IN THIS AREA.
- 5. PARTS COMPLY WITH AMP SOLDERABILITY SPEC. NO. 109-11-2.
- 6. ONE HOLE MAY BE UNDERSIZED (.035/.032 DIA.) FOR ASSEMBLY RETENTION DURING WAVE SOLDERING.
- 7. MATERIAL: HEADER-THERMOPLASTIC POLYESTER
 UL94V-0(NATURAL)
 POST-COPPER ALLOY (SEE NOTES 13,14,& 17 FOR PLATING)
 TUBE-RIGED PVC (CLEAR)
 PLUG-KRATON (BLACK)
- 8. COORDINATE DIMENSION APPLIES FROM CENTER OF ACTUAL FEATURE.
- 9. PLASTIC BURRS CAUSED BY CUT-OFF TOOLING ARE PERMITTED WITHIN THE MAXIMUM TOLERANCE ENVELOPE.
- 10. POST TO BE MEASURED WHEN STRIP IS HELD FLAT.
- 11. POST MUST WITHSTAND TWO 90° BENDS AGAINST EXTRUSION WITHOUT BREAKING.
- 12. DIMENSION SHOULD BE .130 MIN WHEN MATING WITH A MTA 100 CONNECTOR ASSEMBLY OR A CST 100 CONNECTOR.
- 13. GOLD PLATE AREA,.000015 MIN.,ALL SIDES,OVER NICKEL UNDERPLATE,.000050 MIN.,ALL SIDES AND ENTIRE LENGTH OF POST.
- 14. BRIGHT TIN/LEAD (93/7) PLATE AREA,.000150-.000350 THICK,ALL FOUR SIDES,.140 MIN.
- 15. CONVERSION TABLE INCLUDES DIMENSIONS FROM SHEET 1 AND 2.
- 16. TUBE MUST MAINTAIN PART ORIENTATION AND ALLOW FREE SLIDING AT A 45° TUBE INCLINE.
- 17. BRIGHT TIN PLATE AREA,.000150-.000350 THICK,ALL FOUR SIDES,.140 MIN.
- 18. OBSOLETE PARTS: OBSOLETE CIS STREAMLINING PER D.RENAUD/D.SINISI

13, 17	2	25	.900	22.86	9	3-647373-9
	2	28	.800	20.32	8	3-647373-8
13, 17	2	37	.600	15.24	6	3-647373-6
	2	45	.500	12.70	5	3-647373-5
	2	56	.400	10.16	4	3-647373-4
	2	111	.200	5.08	2	3-647373-2
13, 14	2	25	.900	22.86	9	647373-9
	2	28	.800	20.32	8	647373-8
13, 14	2	37	.600	15.24	6	647373-6
	2	45	.500	12.70	5	647373-5
	2	56	.400	10.16	4	647373-4
	2	111	.200	5.08	2	647373-2
FINISH	PLUG	HEADER ASSEMBLY	IN	MM	NUMBER OF POSITIONS	PART NUMBER
	QTY PER TUBE	L				

SUPERSEDED
 SUPERSEDED
 SUPERSEDED



THIS DRAWING IS A CONTROLLED DOCUMENT. DIM A. MSeACHIN 18-NOV-99
 CDR D.P. BOSSI 19-NOV-99
 D.P. BOSSI 19-NOV-99

TE Connectivity

MTA 100 HEADER ASSEMBLY, FRICTION LOCK, NOTCHED, .025 SQUARE STRAIGHT POST, .000015 GOLD PLATED, TUBE LOADED

SCALE: 8:1 SHEET 1 OF 2

CUSTOMER DRAWING

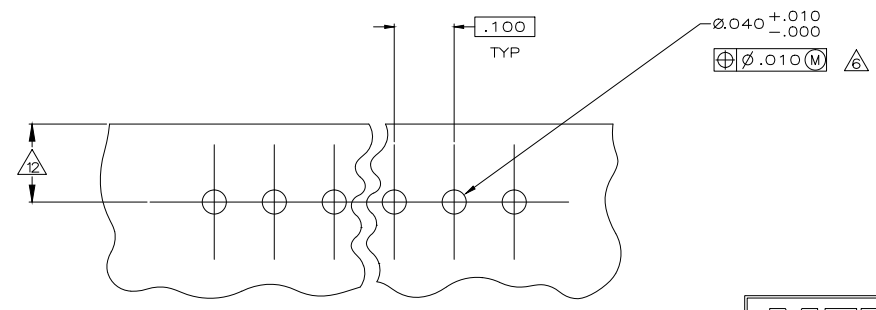
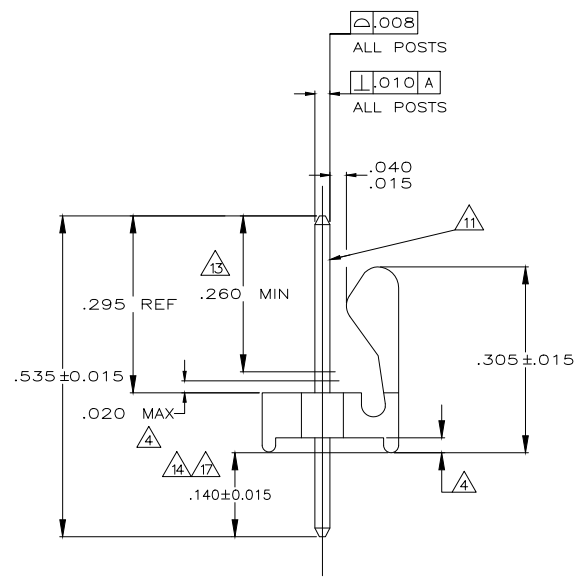
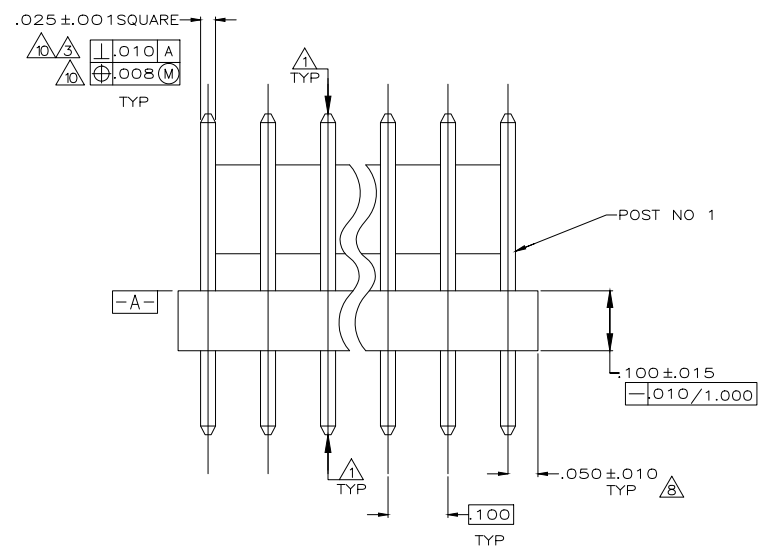
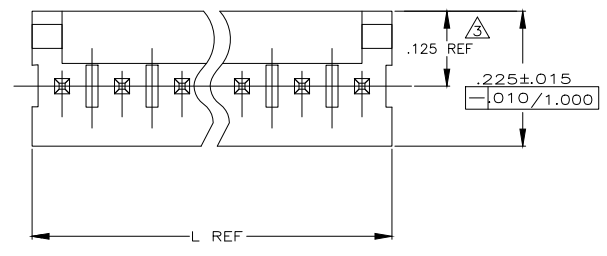

RECOMMENDED MOUNTING HOLE PATTERN FOR .063 THICK P.C. BOARD

THIS DRAWING IS A CONTROLLED DOCUMENT.		DRN D.P. McEACHIN 18-NOV-99	REV 1 19-NOV-99	NAME D.P. BOSSI	DATE 19-NOV-99
DIMENSIONS: INCHES		FRANGES UNLESS OTHERWISE SPECIFIED	PROJECT SPEC	APPLICATION SPEC	RESTRICTED TO
0 R/C	+	-			
1 R/C	+	-			
2 R/C	+	-			
3 R/C	+	-			
4 R/C	+	-			
ANGLES	+	-			
MATERIAL					
FINISH					
CUSTOMER DRAWING					

MTA 100 HEADER ASSEMBLY, FRICTION LOCK, NOTCHED, .025 SQUARE STRAIGHT POST, .00015 GOLD PLATED, TUBE LOADED

SCALE: 8:1 SHEET 2 OF 2 REV B2

单击下面可查看定价，库存，交付和生命周期等信息

[>>TE Connectivity\(泰科\)](#)