

THIS DRAWING IS UNPUBLISHED. RELEASED FOR PUBLICATION
 © COPYRIGHT - By - ALL RIGHTS RESERVED.

REVISIONS				
P	LTR	DESCRIPTION	DATE	APVD
D3		REV PER ECR-16-009964	09AUG2016	JH TIM

- SPECIFICATIONS:
MAGNET WIRE #12 - #20 AWG,
2.03mm (.080") - 0.81mm (.032") DIA COPPER.
OTHER SIZES MAY BE ACCOMMODATED,
CONSULT TYCO ELECTRONICS FOR APPROVAL.
- POCKET RECOMMENDATION : #1601435
- TERMINAL APPLICATION TO COMPLY
WITH TYCO ELECTRONICS SPEC 114-13210, FIG 6
- DIMENSIONS SHOWN DO NOT INCLUDE PLATING.
- PRELIMINARY - NOT FOR PRODUCTION.

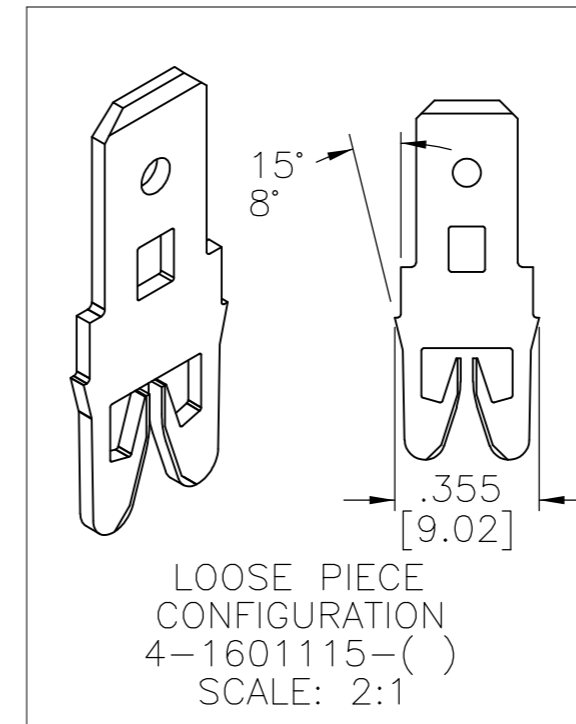
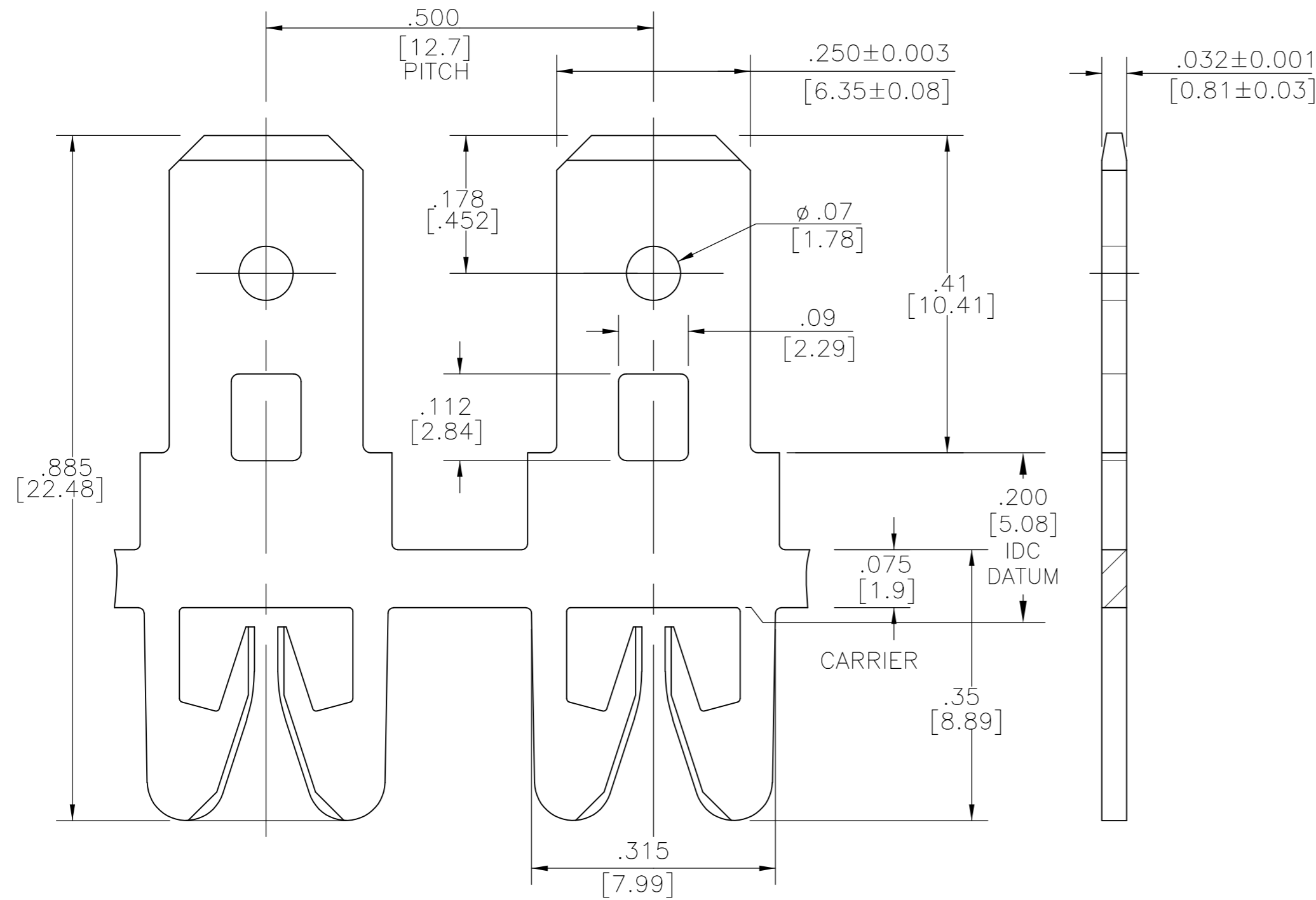

OBSOLETE

-	-	-
-	-	-
POST TIN PLATE OVER COPPER UNDERPLATE	-	4-1601115-2
UNPLATED	032-009-000	4-1601115-1
POST TIN PLATE OVER COPPER UNDERPLATE	132-009-001	1601115-2
UNPLATED	132-009-000	1601115-1
FINISH	REFERENCE PART NUMBER	PART NUMBER
THIS DRAWING IS A CONTROLLED DOCUMENT.		DWN MS FEHER 11JAN2002
DIMENSIONS: INCHES		CHK M.FEHER 11JAN2002
TOLERANCES UNLESS OTHERWISE SPECIFIED:		APVD K.RANDOLPH 11JAN2002
0 PLC ± -	1 PLC ± -	NAME
2 PLC ± .01[0.25]	3 PLC ± .005[0.13]	PRODUCT SPEC
4 PLC ± -	ANGLES ± 2°	108-2316
MATERIAL BRASS, SPRING HARD	FINISH SEE TABLE	APPLICATION SPEC
WEIGHT 0.000000		SIZE A2
CUSTOMER DRAWING		CAGE CODE 00779
SCALE 1:4		DRAWING NO C-1601115
SHEET 1 of 1		RESTRICTED TO -
REV D3		

TE Connectivity

HEAVY RANGE WIRE TO .250 X .032 TAB SIAMEZE TERMINAL

单击下面可查看定价，库存，交付和生命周期等信息

[>>TE Connectivity\(泰科\)](#)