

THIS DRAWING IS UNPUBLISHED. RELEASED FOR PUBLICATION
 © COPYRIGHT - By - ALL RIGHTS RESERVED.

REVISIONS				
P	LTR	DESCRIPTION	DATE	APVD
J		REV PER ECO-16-001441	29FEB16	KG DE

- 1. TE INFO MARKED PER MIL-STD-130.
- 2. MATES WITH 858059-2.

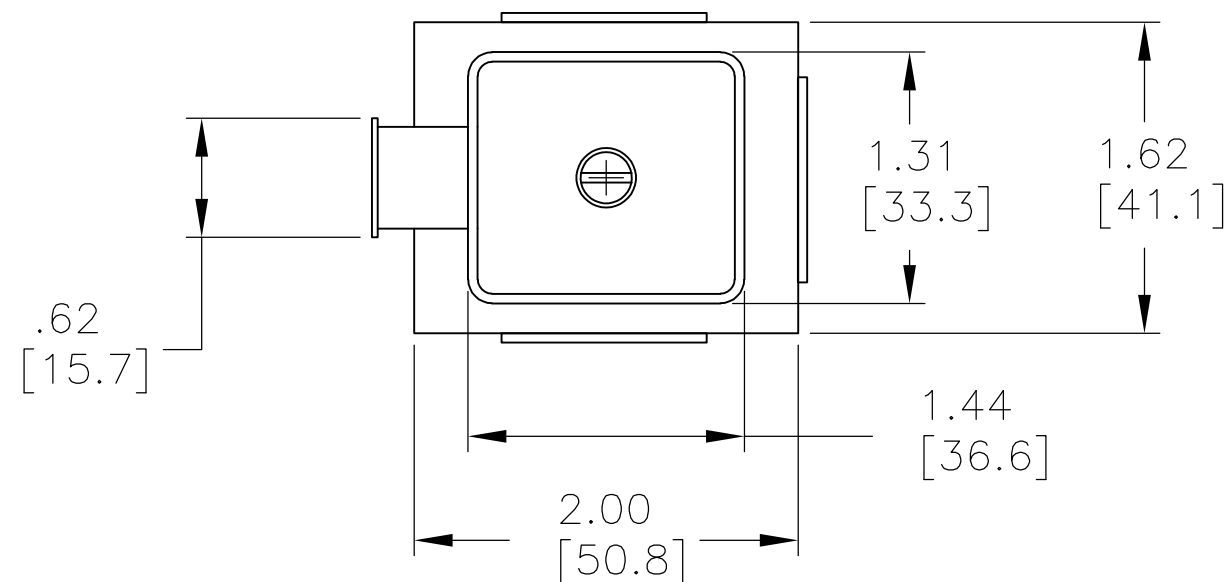
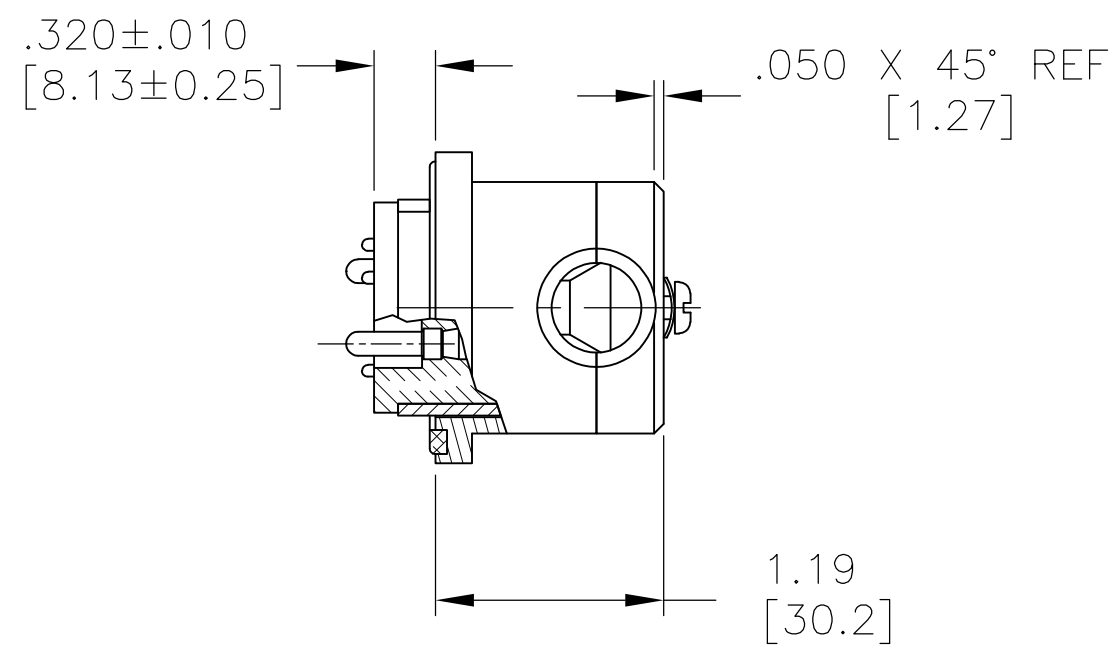
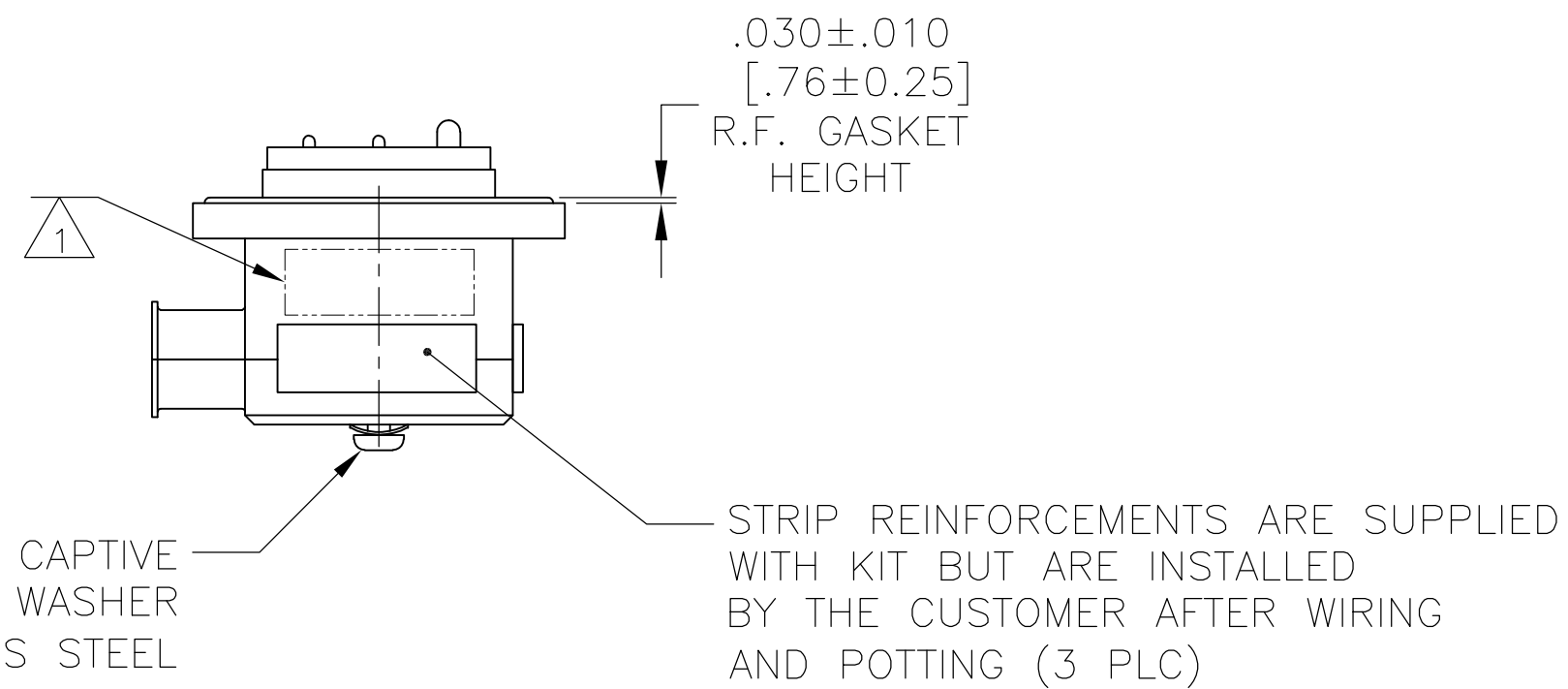
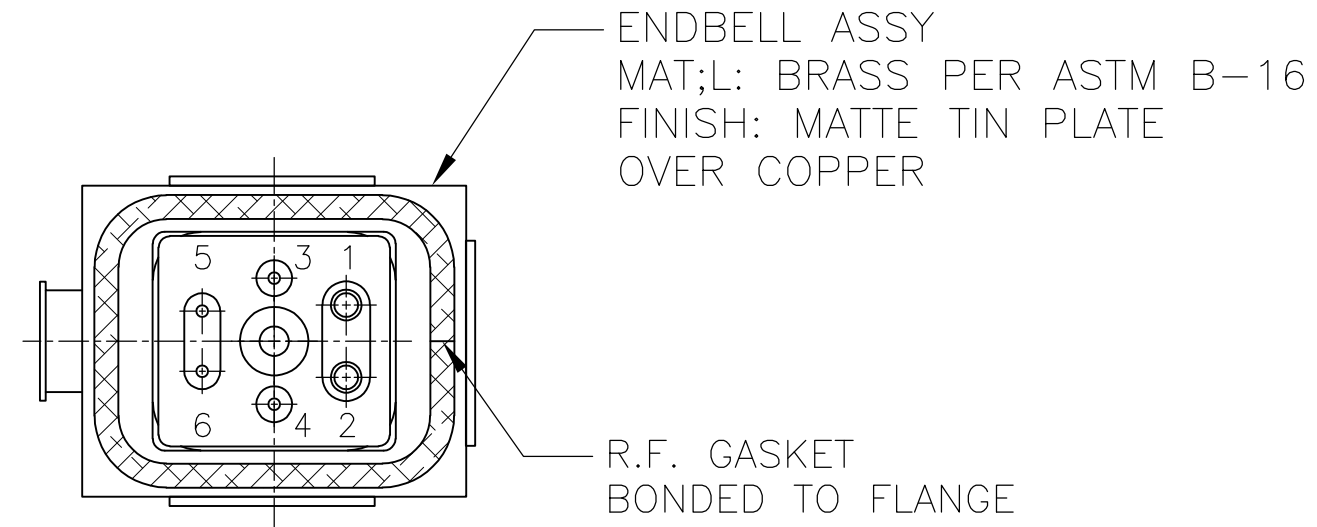

	85/15 FLOUROSILICONE/SILICONE MOLDING COMPOUND	861684-2
OBSOLETE	SILICONE RUBBER MLDG. CMPD.	861684-1
	MOLDED PLUG MATERIAL	PART NO.

THIS DRAWING IS A CONTROLLED DOCUMENT.		DWN C.C.THOMAS 6-4-09	TE TE Connectivity	
DIMENSIONS: INCHES		CHK D.EABY 6-4-09		
TOLERANCES UNLESS OTHERWISE SPECIFIED:		APVD D.EABY 6-4-09	NAME PLUG AND ENDBELL ASSY,LGH	
0 PLC ± -		PRODUCT SPEC	-	
1 PLC ± -		APPLICATION SPEC	-	
2 PLC ± .03 [0.8]			SIZE	CAGE CODE
3 PLC ± -			A2	00779
4 PLC ± -			DRAWING NO	RESTRICTED TO
ANGLES ± -		WEIGHT 0	C=861684	-
FINISH SEE CALLOUTS		CUSTOMER DRAWING	SCALE 1:1	SHEET 1 of 1
MATERIAL SEE CALLOUTS			REV J	

单击下面可查看定价，库存，交付和生命周期等信息

[>>TE Connectivity\(泰科\)](#)