

THIS DRAWING IS UNPUBLISHED. RELEASED FOR PUBLICATION 20
 © COPYRIGHT 20 BY TYCO ELECTRONICS CORPORATION. ALL RIGHTS RESERVED.

LOC		DIST		REVISIONS			
P	LTR	DESCRIPTION		DATE	DWN	APVD	
-	-	C1	REVISED PER ECO-11-005009	12MAR2011	HMR	CR	

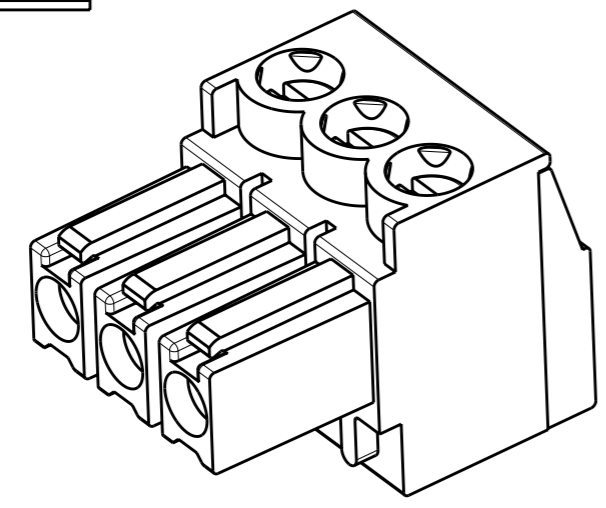
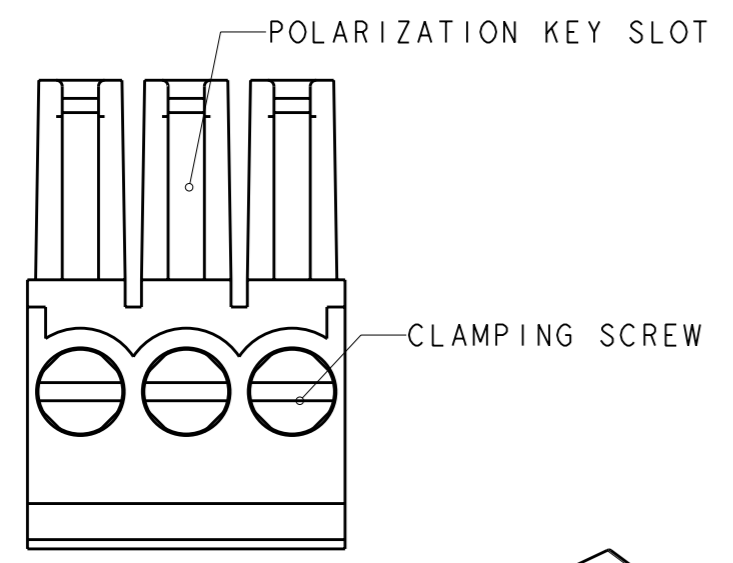
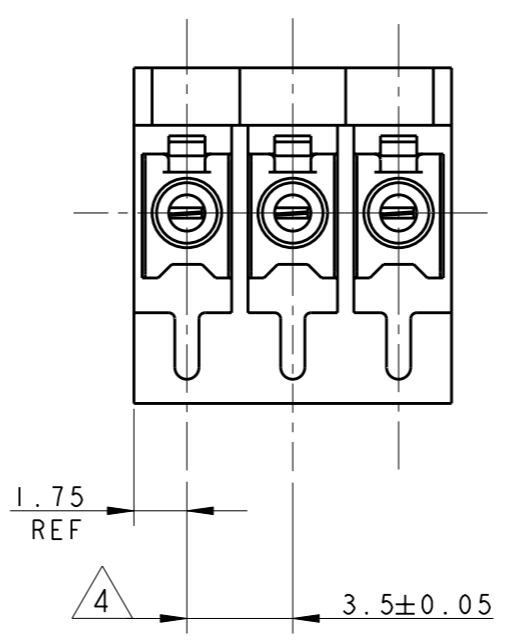
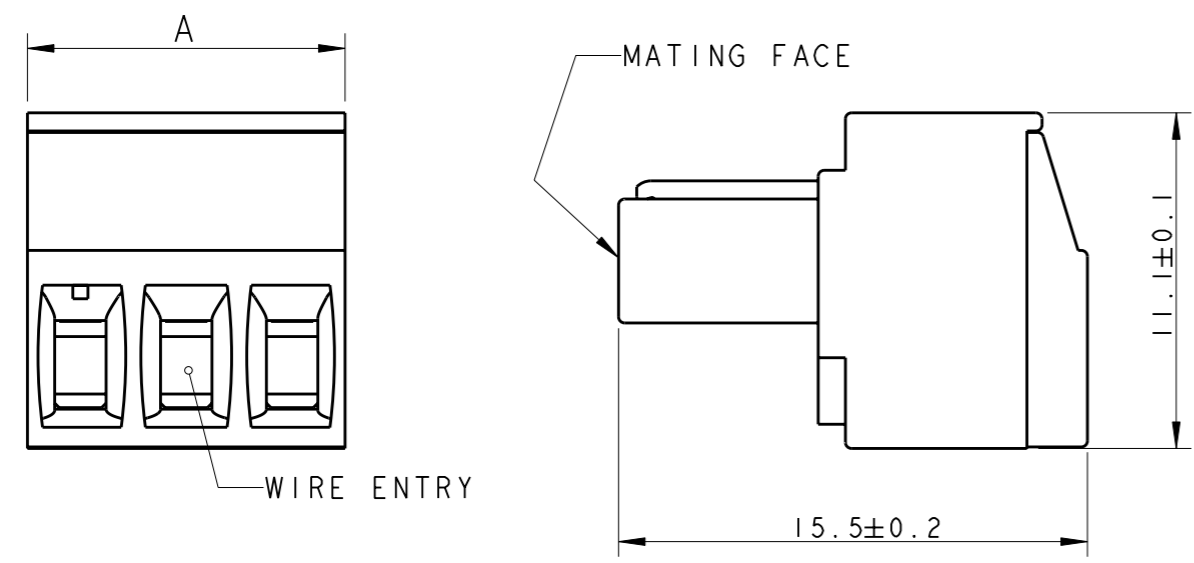

1776242-3 AS SHOWN

- 1 MATERIALS AND FINISH
 HOUSING : PA 6.6, UL 94-V0, COLOR BLACK
 CLAMP : BRASS, NICKEL PLATED.
 TERMINAL : BRASS, PLATING: SEE TABLE.
 CONTACT SPRING : PHOSPHOR BRONZE, TIN PLATED
 CLAMPING SCREW : M2, BRASS, NICKEL PLATED
- 2 END-TO-END STACKABLE WITHOUT LOSS OF CENTERLINE SPACING
- 3 WIRE SIZE RANGE: 14-30 AWG.
- 4 NOT CUMULATIVE TOLERANCE.
- 5 PRELIMINARY PART NUMBER.

TERMINAL PLATING	A	NO OF POSN	PART NUMBER
TIN	35.0	10	5 1-1776242-0
TIN	31.5	9	5 1776242-9
TIN	28.0	8	5 1776242-8
TIN	24.5	7	5 1776242-7
TIN	21.0	6	5 1776242-6
TIN	17.5	5	5 1776242-5
TIN	14.0	4	1776242-4
TIN	10.5	3	5 1776242-3
TIN	7.0	2	1776242-2

<small>THIS DRAWING IS A CONTROLLED DOCUMENT FOR TYCO ELECTRONICS CORPORATION. IT IS SUBJECT TO CHANGE AND THE CONTROLLING ENGINEERING ORGANIZATION SHOULD BE CONTACTED FOR THE LATEST REVISION.</small>		DWN 02SEP2009 S SCHLEGEL CHK 02SEP2009 C RICHARD APVD 02SEP2009 C RICHARD	Tyco Electronics Harrisburg, PA 17105-3608
DIMENSIONS: mm	TOLERANCES UNLESS OTHERWISE SPECIFIED: 0 PLC ±. 1 PLC ±.3 2 PLC ±.25 3 PLC ±. 4 PLC ±. ANGLES ±2	PRODUCT SPEC 108-20166 APPLICATION SPEC 114-20079	NAME TERMINAL BLOCK PLUG STACKING 3.5mm PITCH
MATERIAL	FINISH	WEIGHT	SIZE CAGE CODE DRAWING NO RESTRICTED TO A300779 C-1776242 -
CUSTOMER DRAWING		SCALE 4:1	SHEET 1 OF 1 REV C1

单击下面可查看定价，库存，交付和生命周期等信息

[>>TE Connectivity\(泰科\)](#)