

REVISIONS				
P	LTN	DESCRIPTION	DATE	APVD
C		REVISED PER ECO-17-012537	25AUG2017	TX SH
D		REVISED PER ECO-18-014172	06SEP2018	TX SH
E		REVISED PER ECO-18-018343	22NOV2018	TX SH

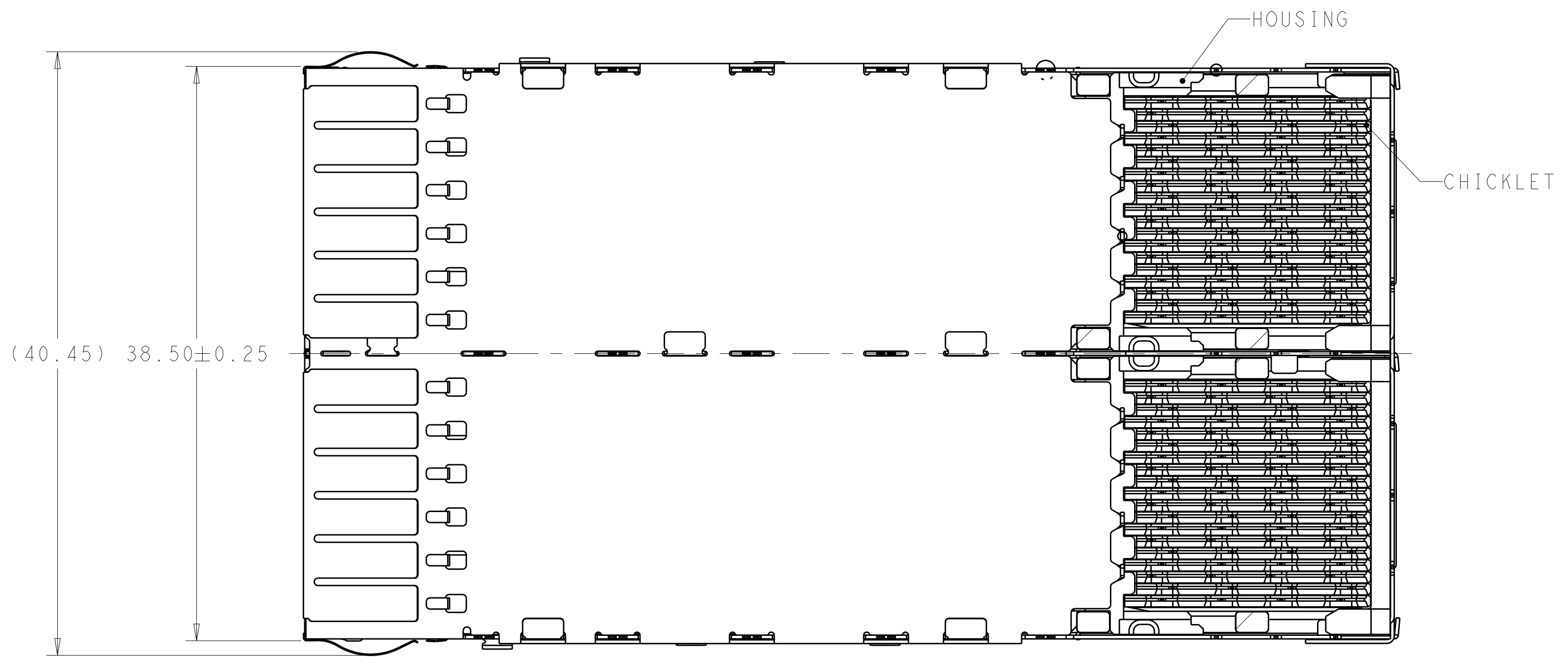
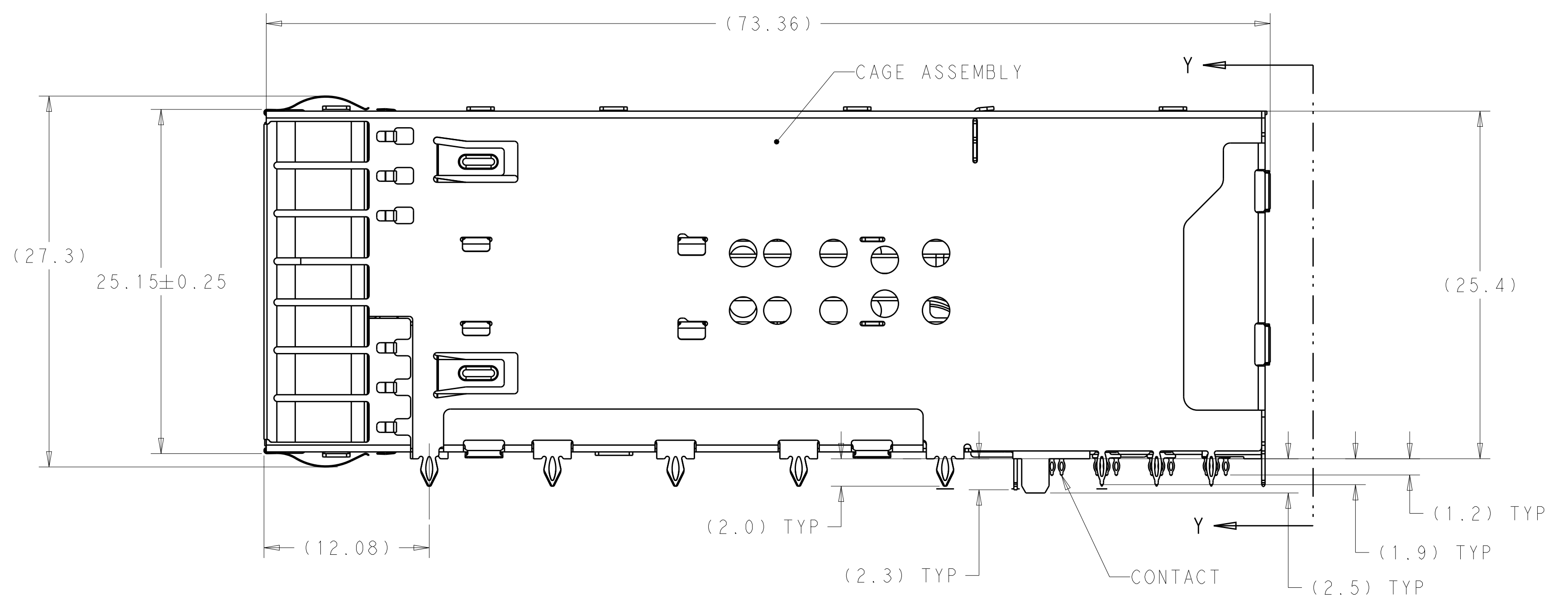
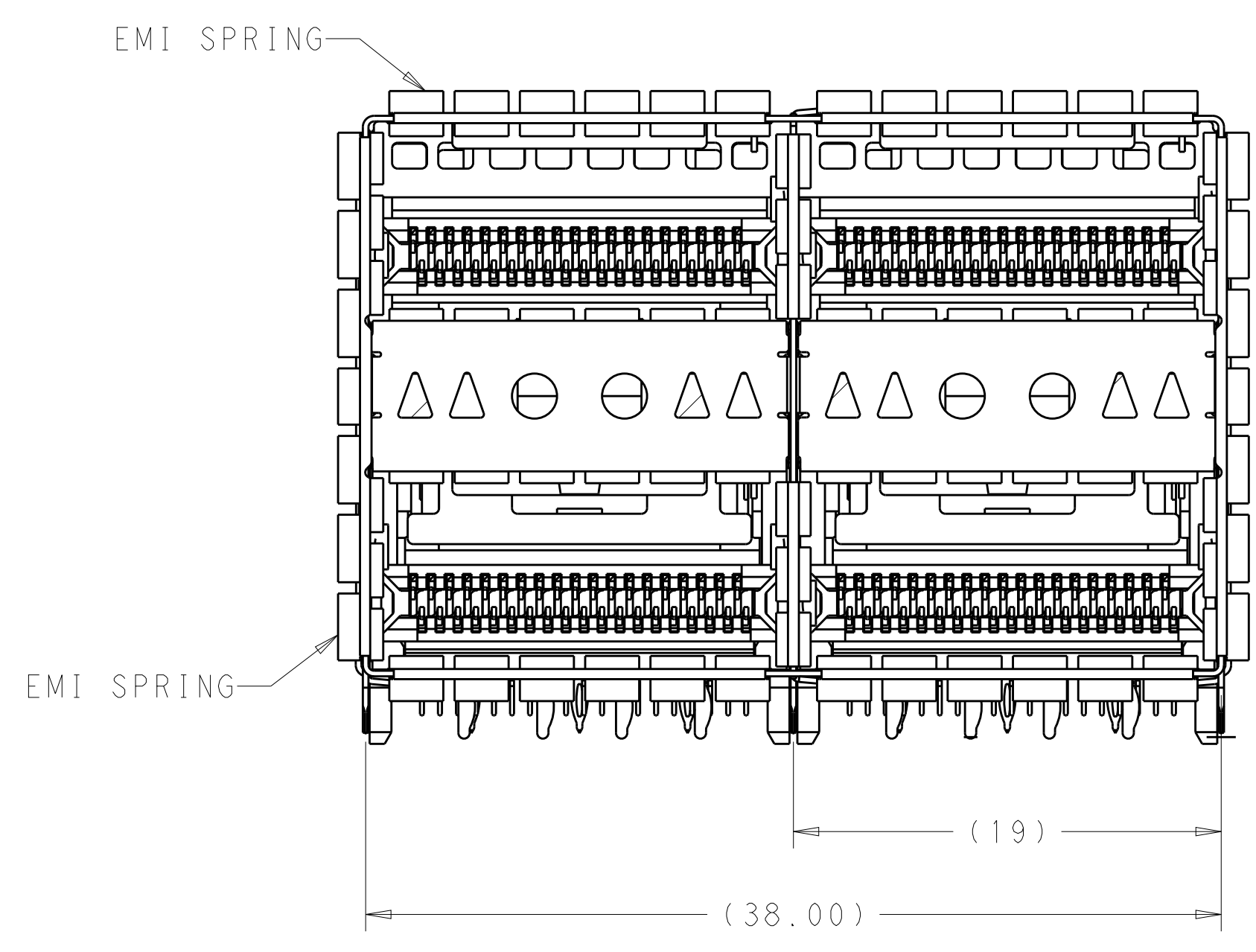

- MATERIALS:
 CAGE ASSEMBLY- NICKEL SILVER ALLOY PER ASTM B 122.
 EMI SPRING- COPPER ALLOY, NICKEL PLATED.
 HOUSING- POLYESTER LCP WITH 94V-0.
 CHICKLET- POLYESTER LCP WITH 94V-0.
 CONTACT- COPPER ALLOY.
 LIGHTPIPE- POLYCARBONATE WITH 94V-0.
- CONTACT FINISH: 0.76µm GOLD ON MATING AREA, 0.7-1.5µm MATT TIN ON COMPLIANT AREA, ALL OVER 1.27µm NICKEL.
- DATUM AND BASIC DIMENSION ESTABLISHED BY CUSTOMER.
- MINIMUM PCB THICKNESS OF 1.57.
- THE ENTIRE AREA OF THE CONNECTOR FOOTPRINT, INDICATED BY THE DASHED LINE, TO BE CONSIDERED THE KEEPOUT AREA FOR COMPONENTS AND TRACES.
- CROSS-HATCHED AREAS REPRESENT ZONES ON THE PCB THAT COME IN CONTACT WITH OR BE IN CLOSE PROXIMITY TO THE PLASTIC HOUSING OR THE CONNECTOR CAGE. INDICATED AREAS TO BE CONSIDERED TRACE FREE.
- PART NUMBER AND DATE CODE MADE IN APPROXIMATE AREA SHOWN.
- HATCHED AREA IS PLACEMENT ZONE FOR LED. LED SHOULD BE CENTERED WITHIN ZONE. RECOMMEND 0805 PACKAGE.
- CONTACT FINISH: 0.08µm MINIMUM GOLD OVER 0.68µm PALLADIUM-NICKEL ON MATING AREA, 0.7-1.5µm MATT TIN ON COMPLIANT AREA, ALL OVER 1.27µm NICKEL.
- REMOVE THE PCB HOLES FOR 2289129-5, 2289129-8 FOR BELLY TO BELLY APPLICATION.

CONTACT FINISH	DESCRIPTION	PART NUMBER
2	LEFT INDICATOR DOWN, 4LP	1-2289129-3
2	ALL INDICATOR UP, 4LP	1-2289129-1
2	ALL ROUND INDICATOR, 4LP	2289129-9
2	ALL ROUND INDICATOR, 4LP	2289129-8
2	LEFT INDICATOR UP, 2LP	2289129-7
2	ALL INDICATOR DOWN, 4LP	2289129-6
2	LEFT INDICATOR UP, 2LP	2289129-5
2	LEFT INDICATOR UP, 4LP	2289129-4
2	LEFT INDICATOR DOWN, 4LP	2289129-3
2	LEFT INDICATOR UP, 4LP	2289129-2
2	ALL INDICATOR UP, 4LP	2289129-1

THIS DRAWING IS A CONTROLLED DOCUMENT. DIMENSIONS: mm. TOLERANCES UNLESS OTHERWISE SPECIFIED: 0 PLC ±0.25, 2 PLC ±0.15, 3 PLC ±, 4 PLC ±, ANGLES ±.

DATE: 30NOV2014
 DWN: TIM XUE
 CH: JASON YANG
 APVD: JASON YANG

NAME: ZOSFP+ 2X2 WITH EMI SPRING FINGERS 4 INTERNAL LIGHT PIPES
 PRODUCT SPEC: 108-60102
 APPLICATION SPEC: 114-60015

SIZE: A1
 CAGE CODE: 100779
 DRAWING NO: 2289129

RESTRICTED TO: CUSTOMER DRAWING
 SCALE: 4:1
 SHEET: 1 OF 6
 REV: E

REVISIONS				
P.	LTN.	DESCRIPTION	DATE	APP'D.
-	-	SEE SHEET 1	-	-

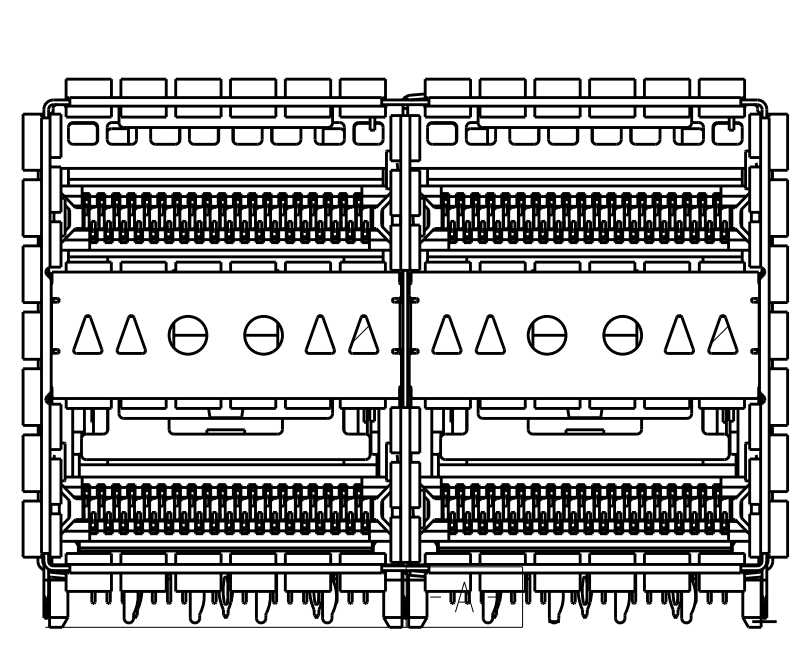

2289129-1
ALL INDICATORS UP
SCALE 5:2

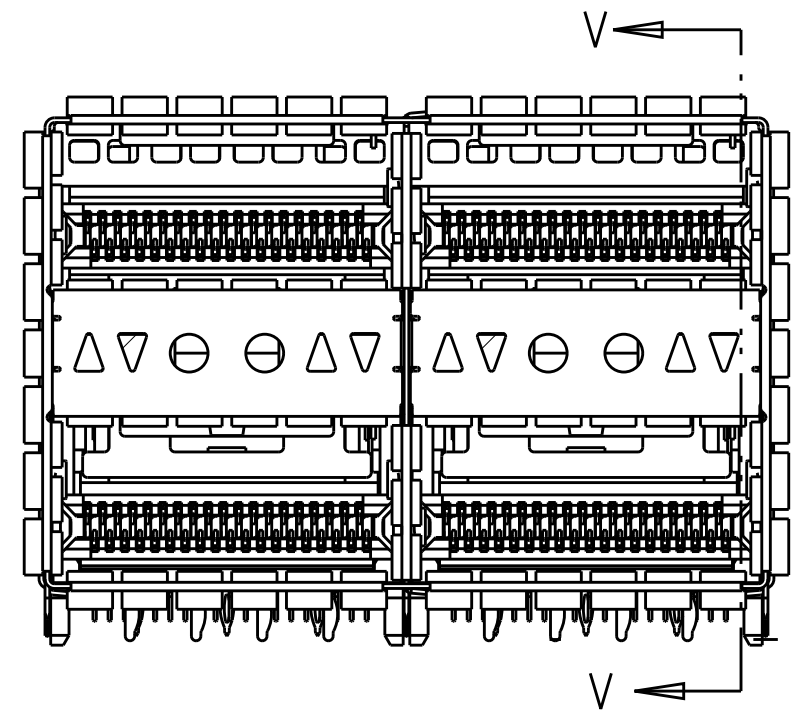

2289129-2
LEFT INDICATOR UP
SCALE 5:2

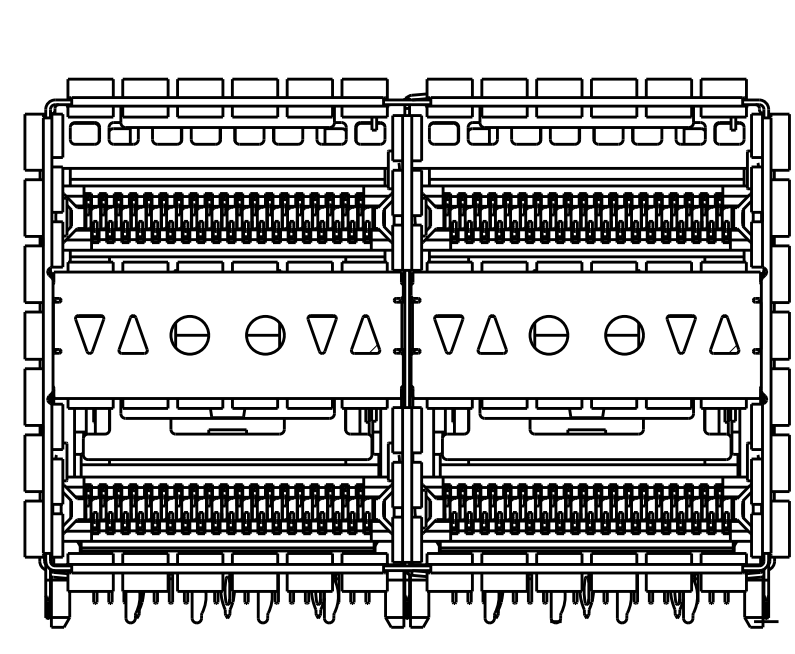

2289129-3
LEFT INDICATOR DOWN
SCALE 5:2

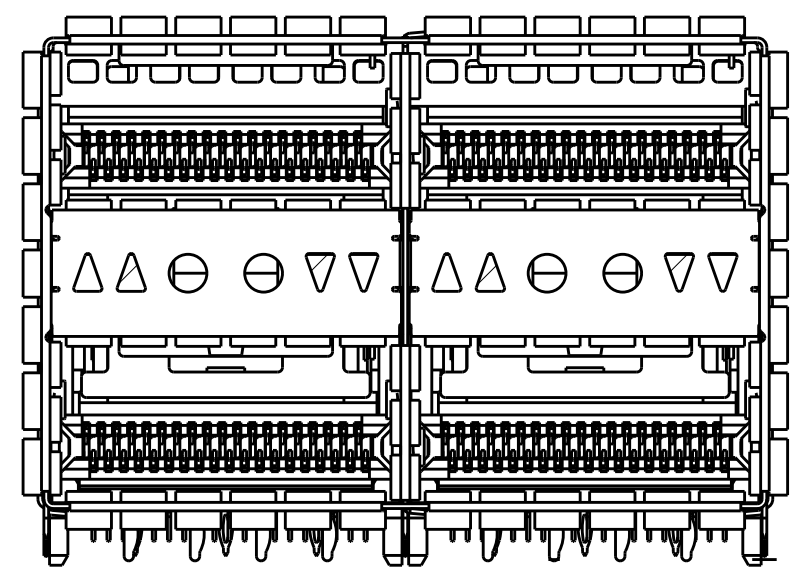

2289129-4
LEFT INDICATOR UP
SCALE 5:2

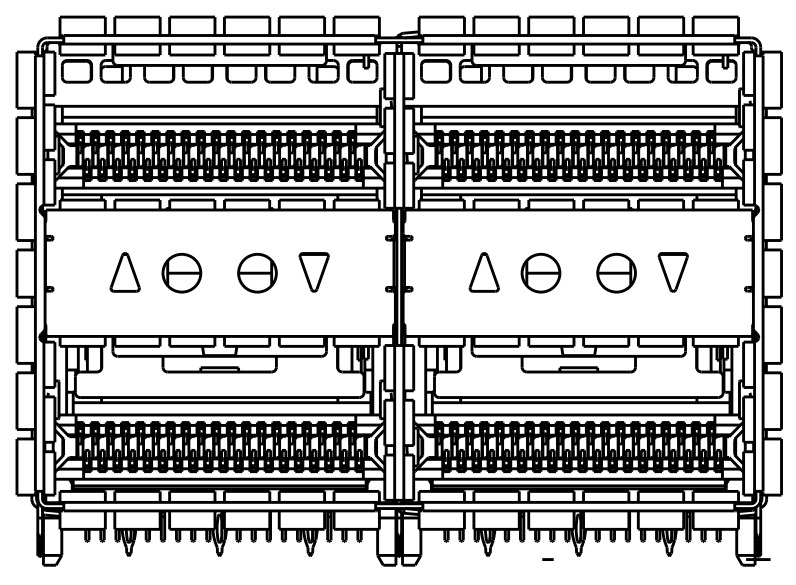

2289129-5
2289129-7
LEFT INDICATORS UP(2 LIGHT PIPES)
SCALE 5:2

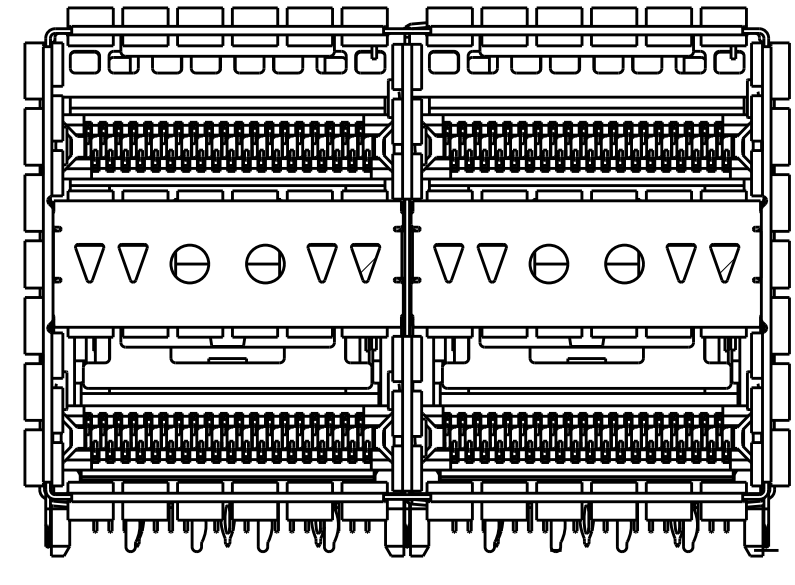

2289129-6
ALL INDICATORS DOWN
SCALE 5:2

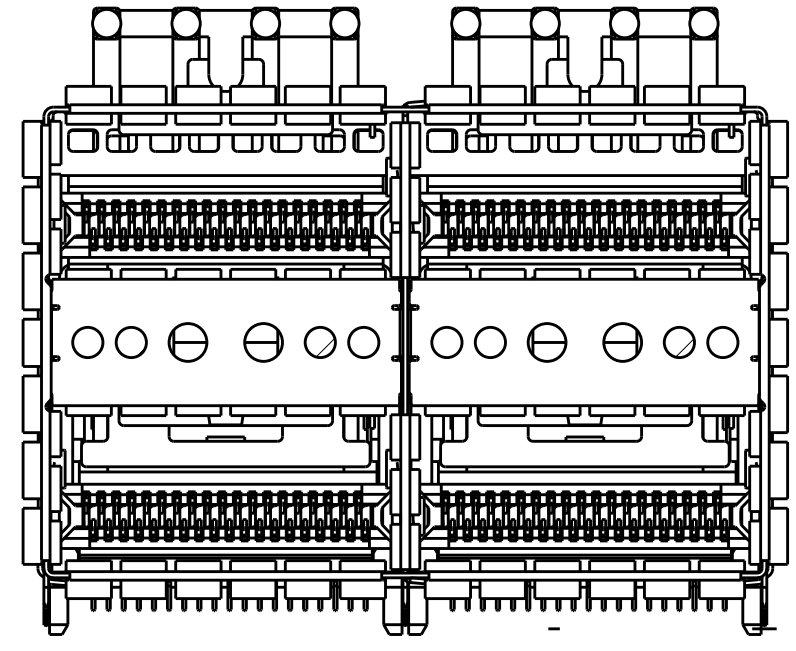

2289129-8
SCALE 5:2

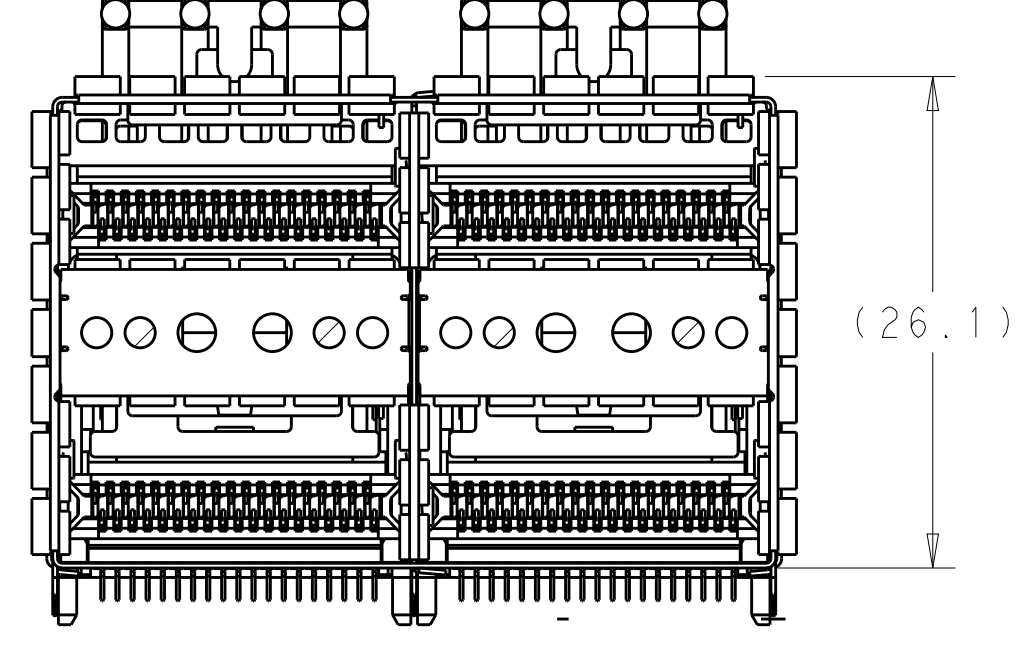

2289129-9 SAME TO 2289129-8
EXCEPT REMOVE THE BOTTOM SPRINGS
SCALE 5:2

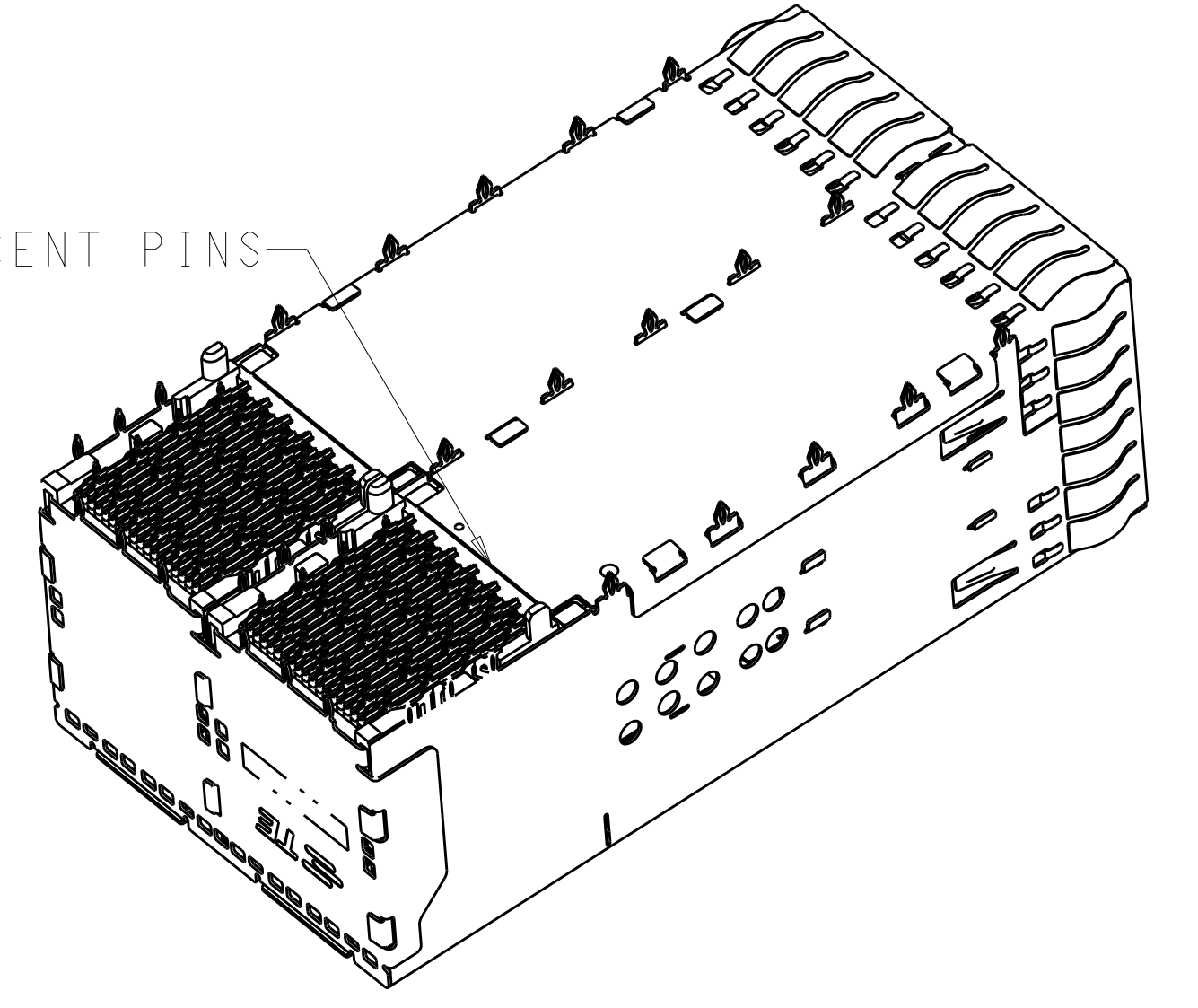

2289129-5, 2289129-7
WITHOUT CRESCENT PINS AS SHOWN
SCALE 2:1

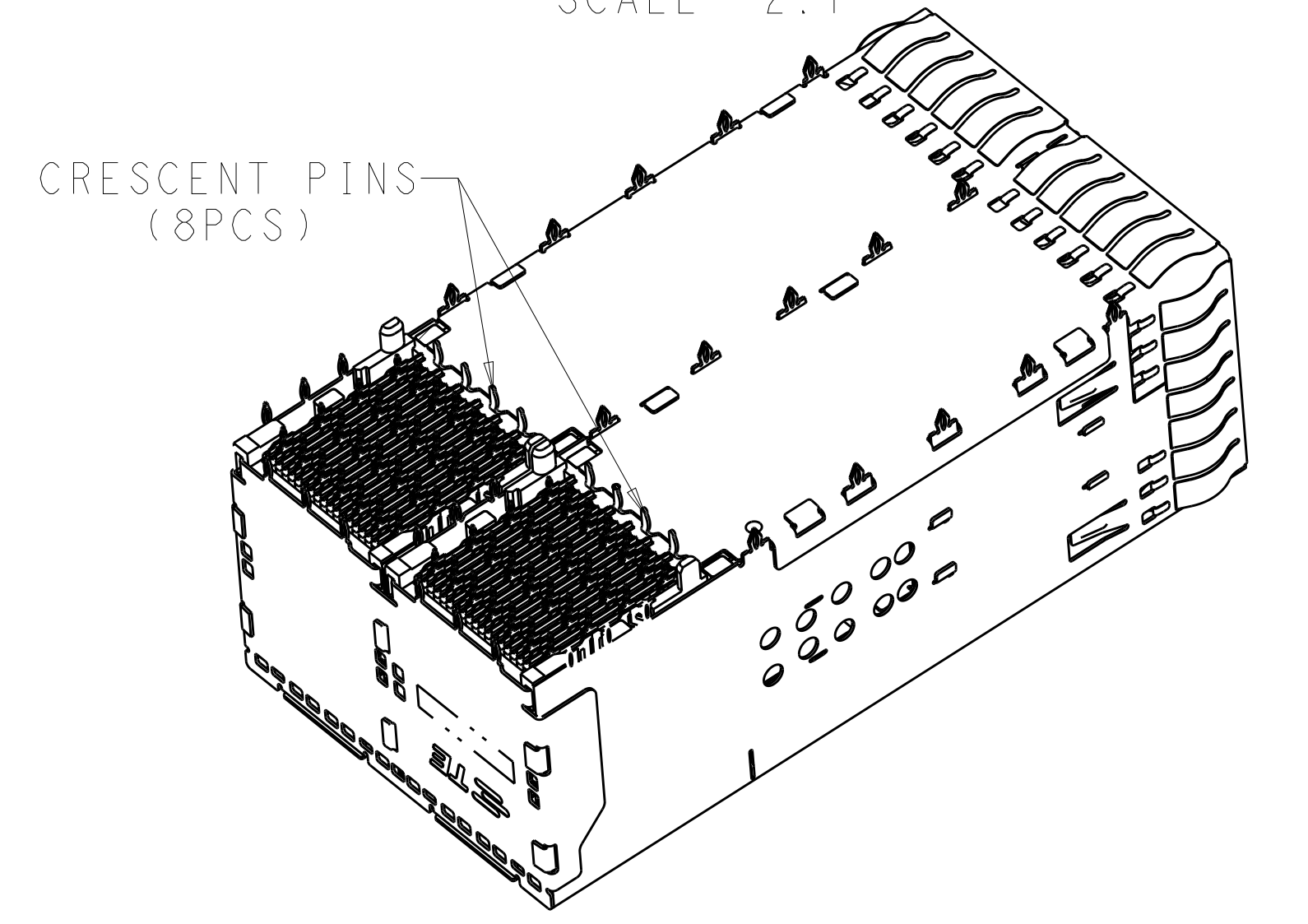

2289129-1 TO 2289129-4 & 2289129-6
WITH CRESCENT PINS AS SHOWN
SCALE 2:1

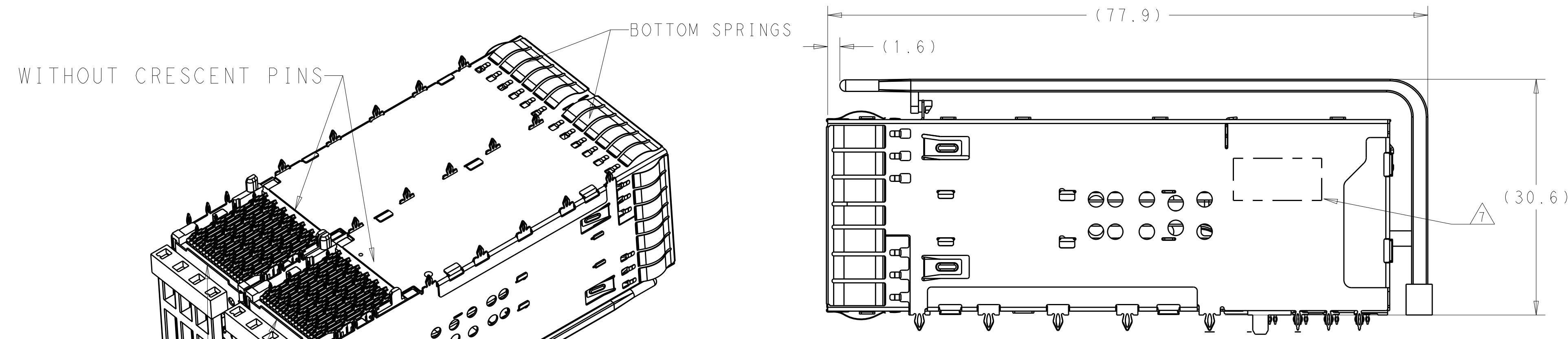

2289129-8
2289129-9 WITHOUT BOTTOM SPRINGS
SCALE 5:2

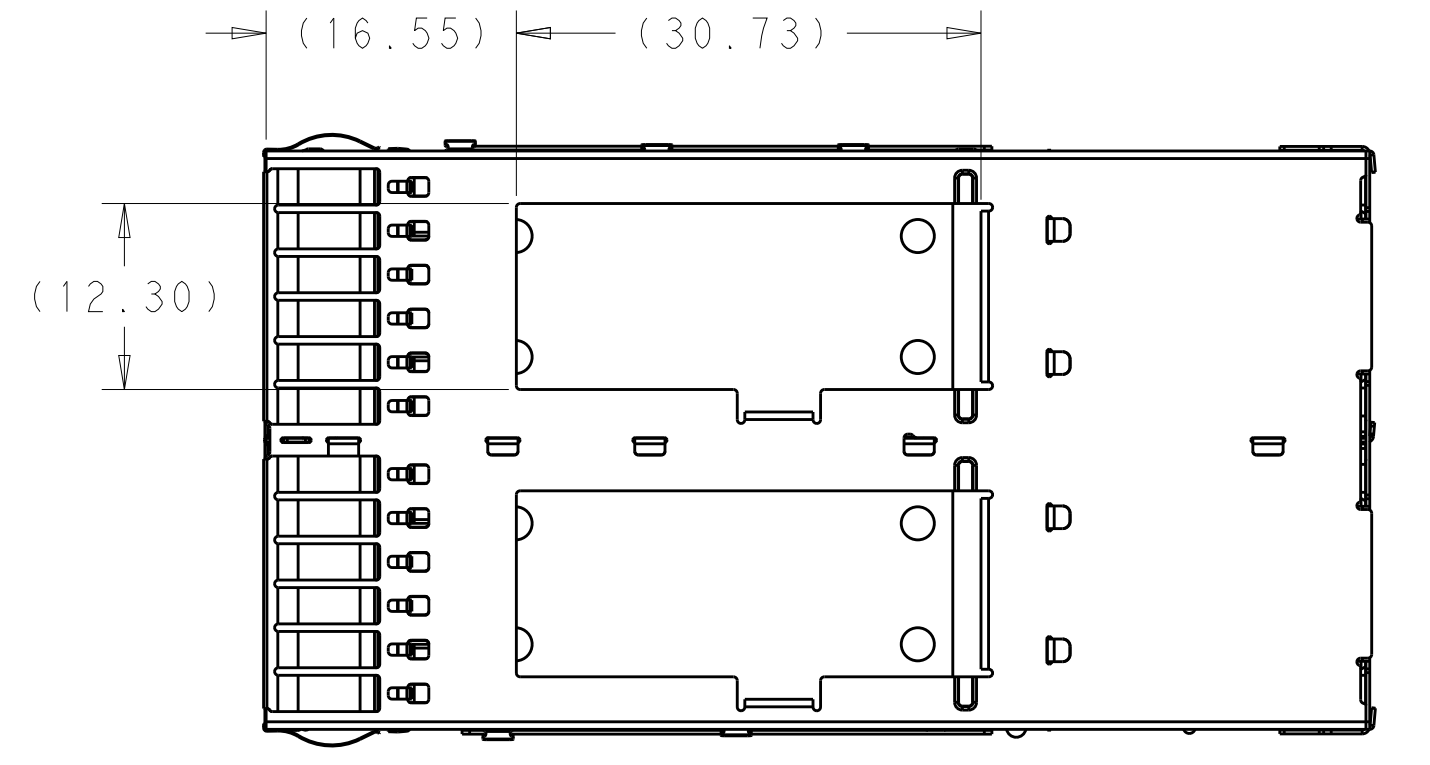

2289129-7 AS SHOWN WITH TOP SLOTS
SCALE 2:1

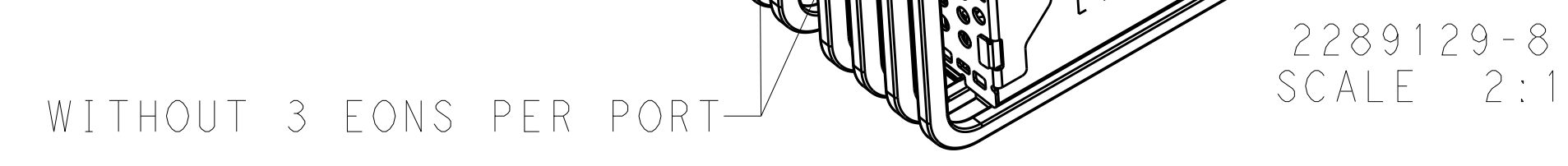

2289129-8
SCALE 2:1

THIS DRAWING IS A CONTROLLED DOCUMENT.		OWN: TIM XUE 30NOV2014	TE Connectivity
DIMENSIONS: mm		CHK: JASON YANG 30NOV2014	
TOLERANCES UNLESS OTHERWISE SPECIFIED:		APP'D: JASON YANG 30NOV2014	NAME: ZOSFP+ 2X2 WITH EMI SPRING FINGERS 4 INTERNAL LIGHT PIPES
0 PLC ±0.25		PRODUCT SPEC: 108-60102	
1 PLC ±0.15		APPLICATION SPEC: 114-60015	SIZE: CAGE CODE: DRAWING NO: A100779 WEIGHT: C=2289129
2 PLC ±0.15		FINISH: CUSTOMER DRAWING	
3 PLC ±0.15		SCALE: 4:1	SHEET 2 OF 6 REV E
4 PLC ±0.15		SEE NOTE 1	
ANGLES ±0.15		SEE NOTE 2	

REVISIONS				
P.	LTN.	DESCRIPTION	DATE	APVD.
-	-	SEE SHEET 1	-	-

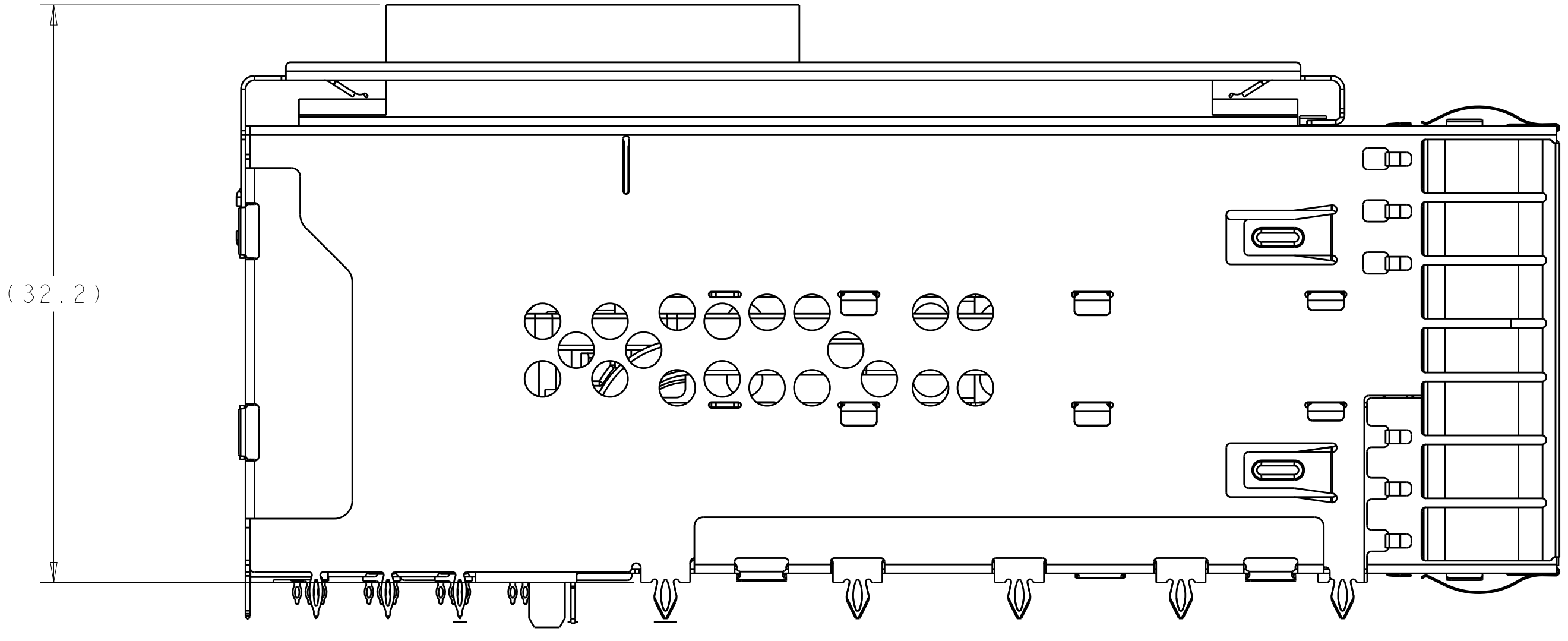

1-2289129-3
SCALE 4:1

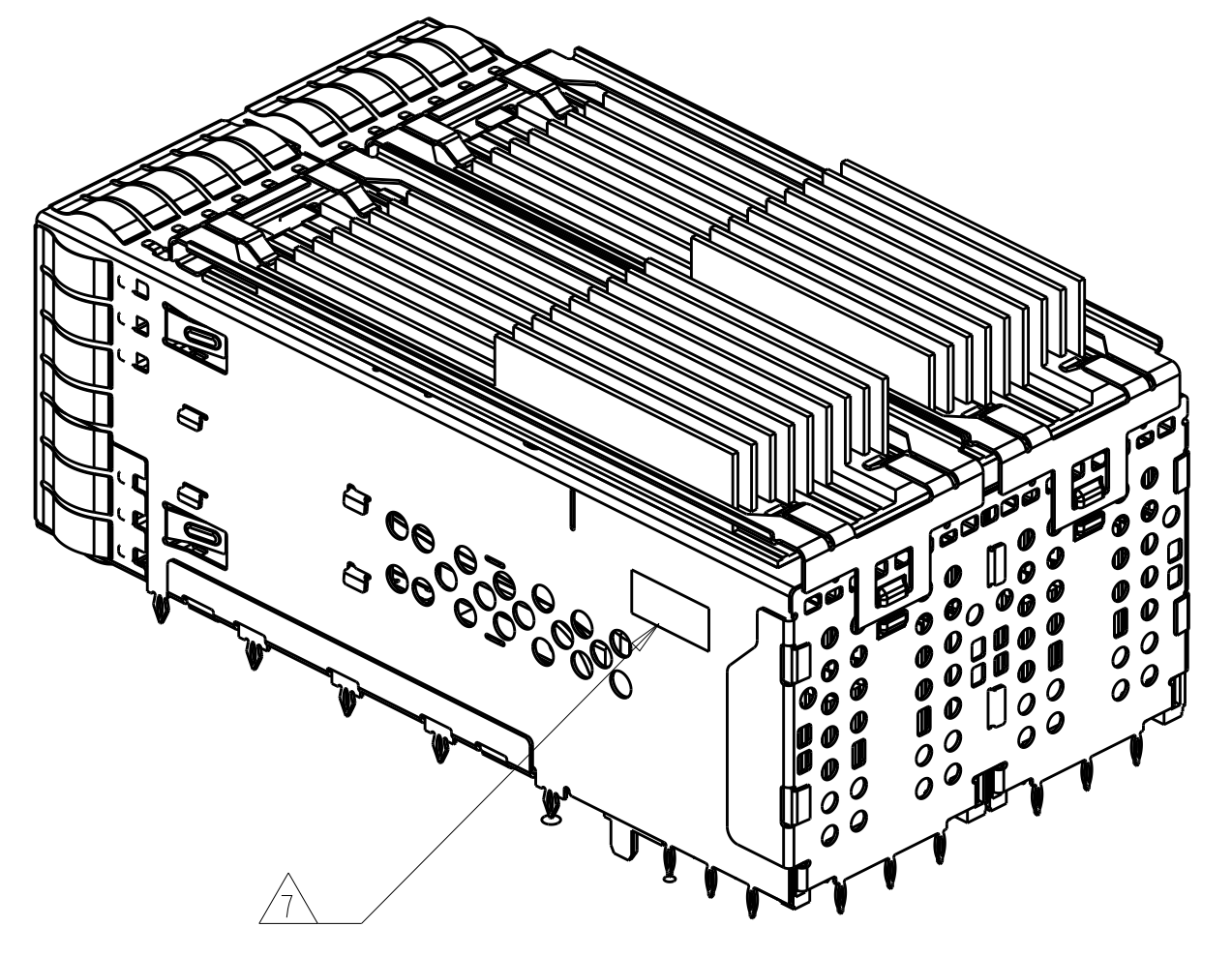
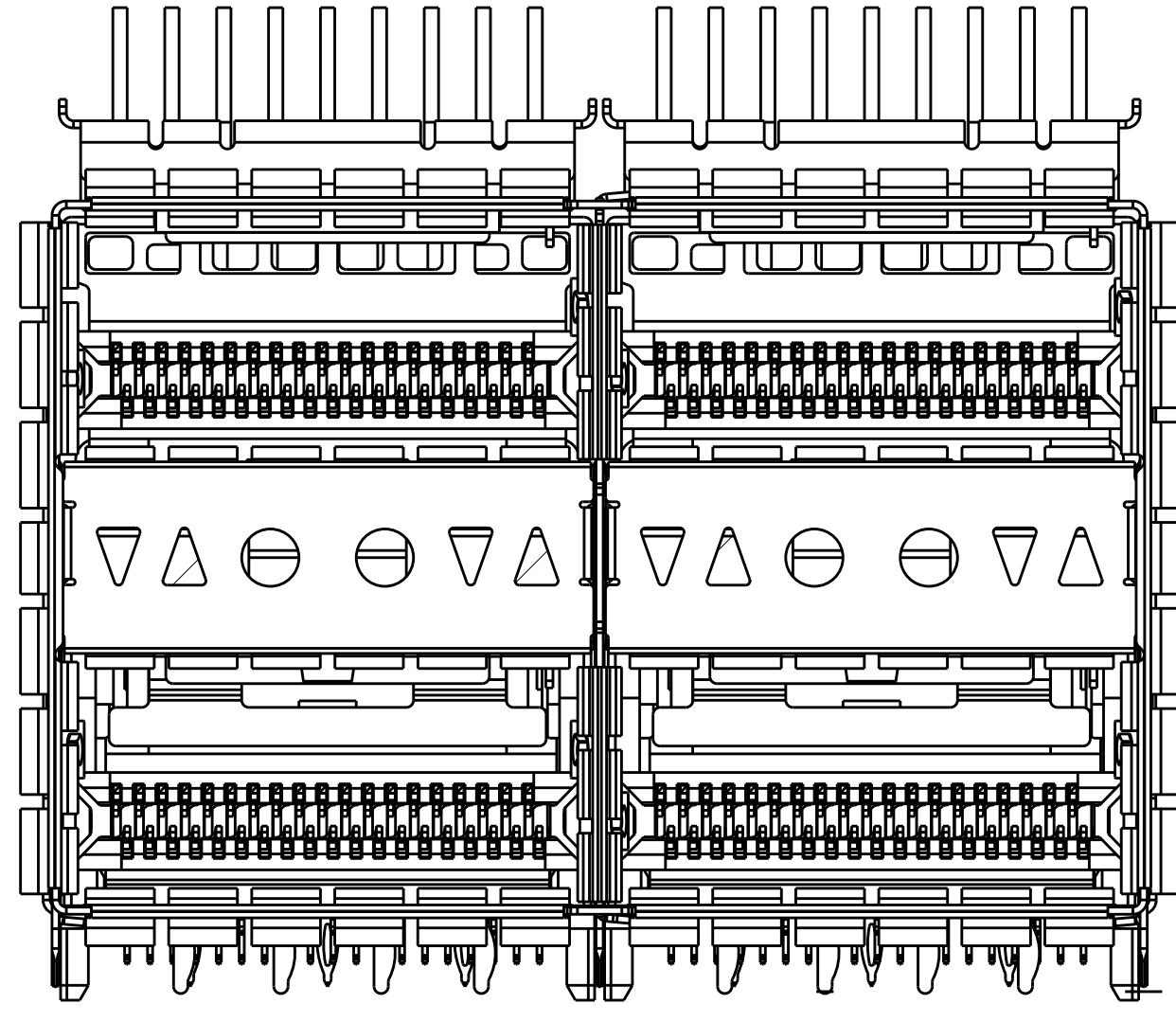

1-2289129-3
SCALE 2:1

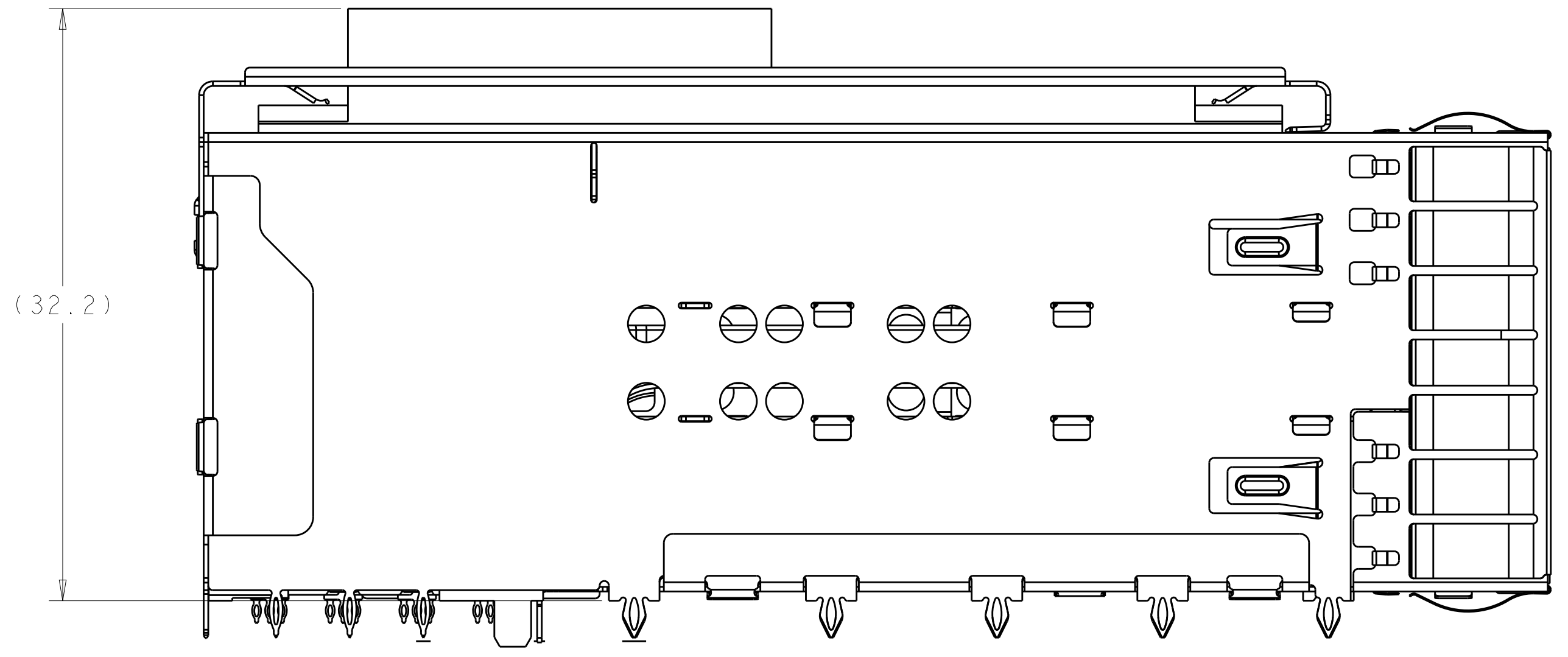

1-2289129-1
SCALE 4:1

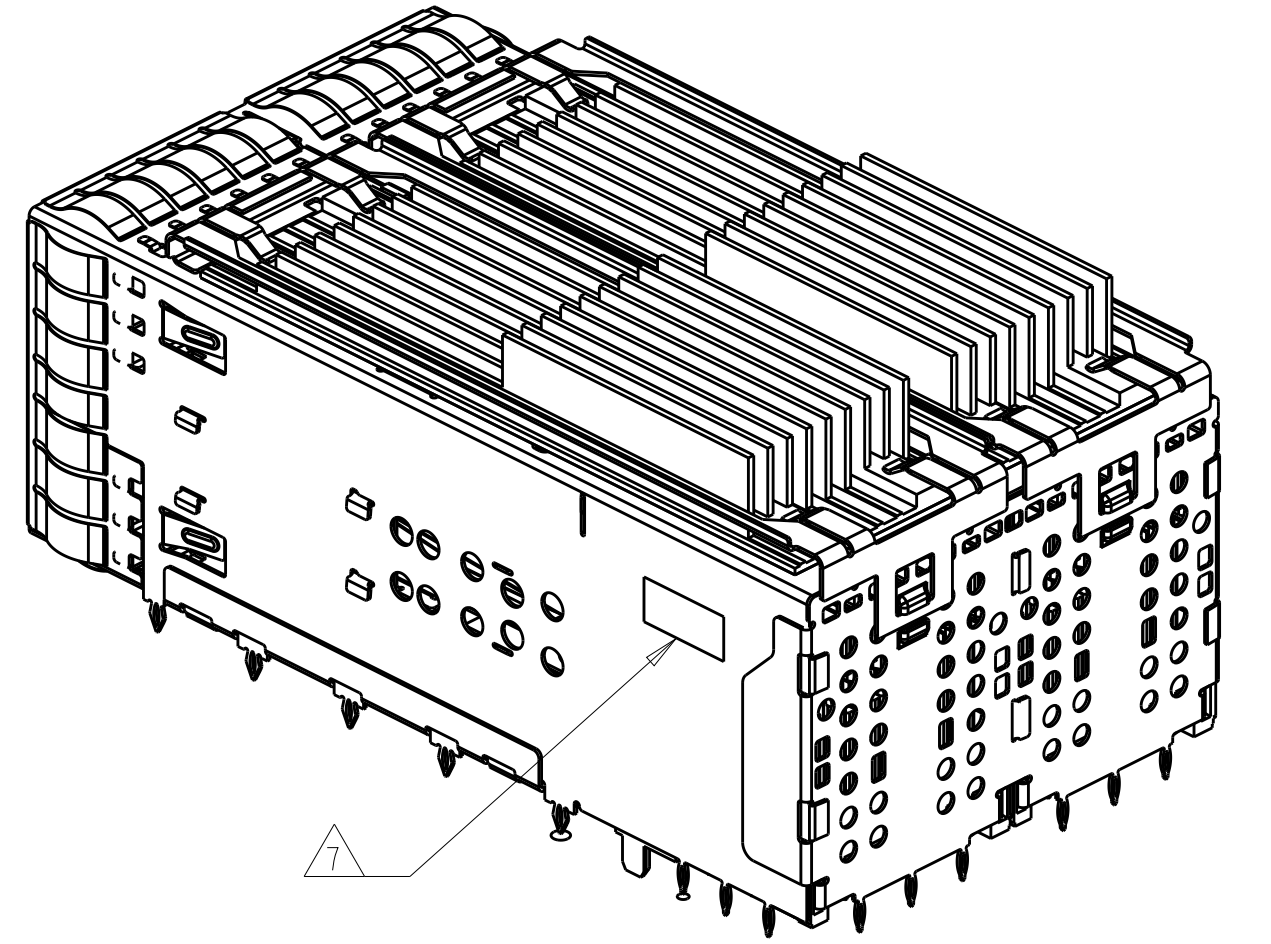
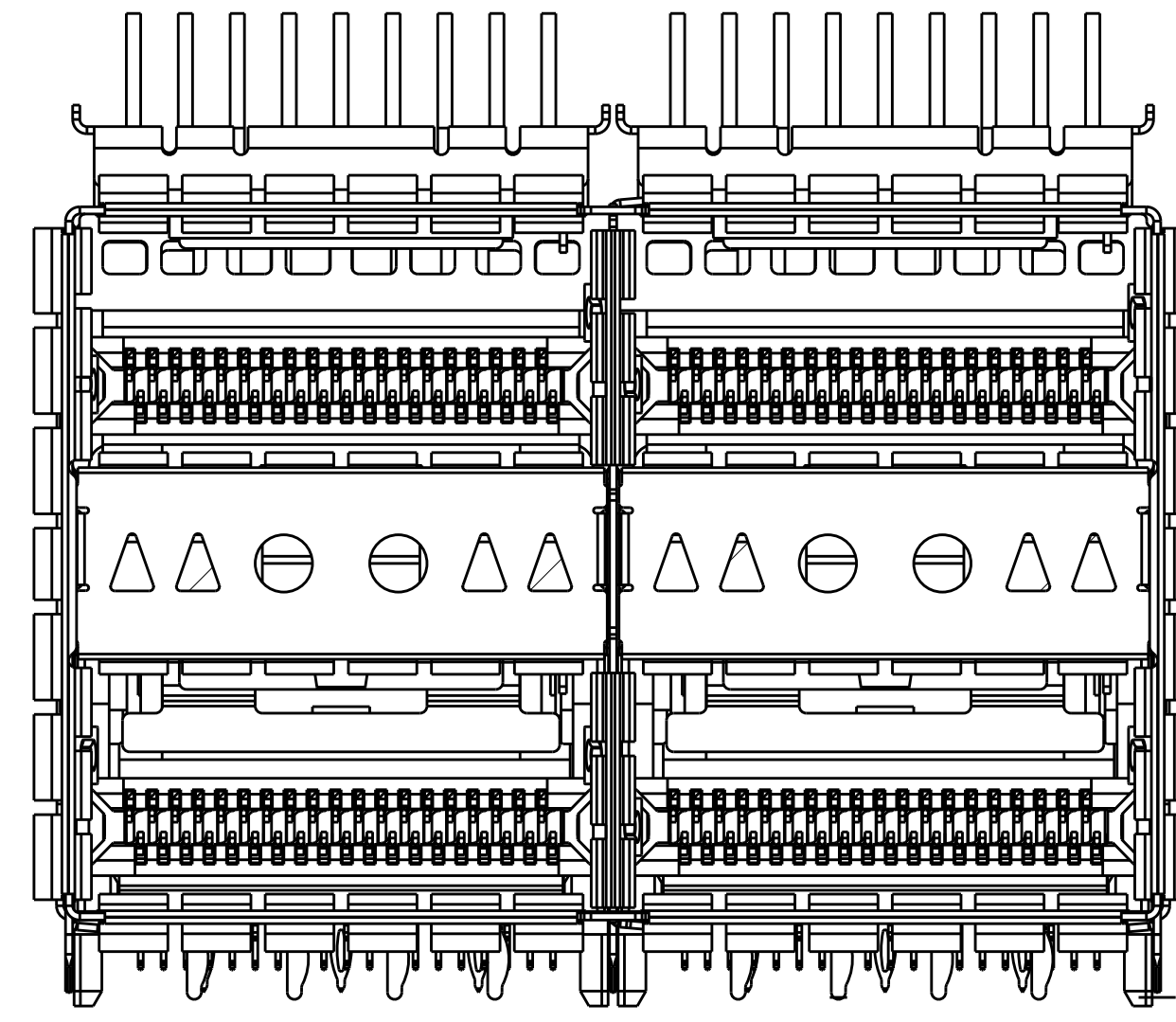

1-2289129-1
SCALE 2:1

THIS DRAWING IS A CONTROLLED DOCUMENT.		DWN: TIM XUE 30NOV2014 CHG: JASON YANG 30NOV2014 APVD: JASON YANG 30NOV2014	
DIMENSIONS: mm	TOLERANCES UNLESS OTHERWISE SPECIFIED: 0 PLC ± 1 PLC ±0.25 2 PLC ±0.15 3 PLC ± 4 PLC ± ANGLES ±	NAME: ZOSFP+ 2X2 WITH EMI SPRING FINGERS 4 INTERNAL LIGHT PIPES PRODUCT SPEC: - APPLICATION SPEC: 108-60102 SIZE: 114-60015	
MATERIAL: - FINISH: - SEE NOTE 1	WEIGHT: - SEE NOTE 2	CUSTOMER DRAWING A100779C=2289129	RESTRICTED TO: - SCALE: 4:1 SHEET 3 OF 6 REV E

REVISIONS				
P.	LTM	DESCRIPTION	DATE	APVD
-	-	SEE SHEET 1	-	-

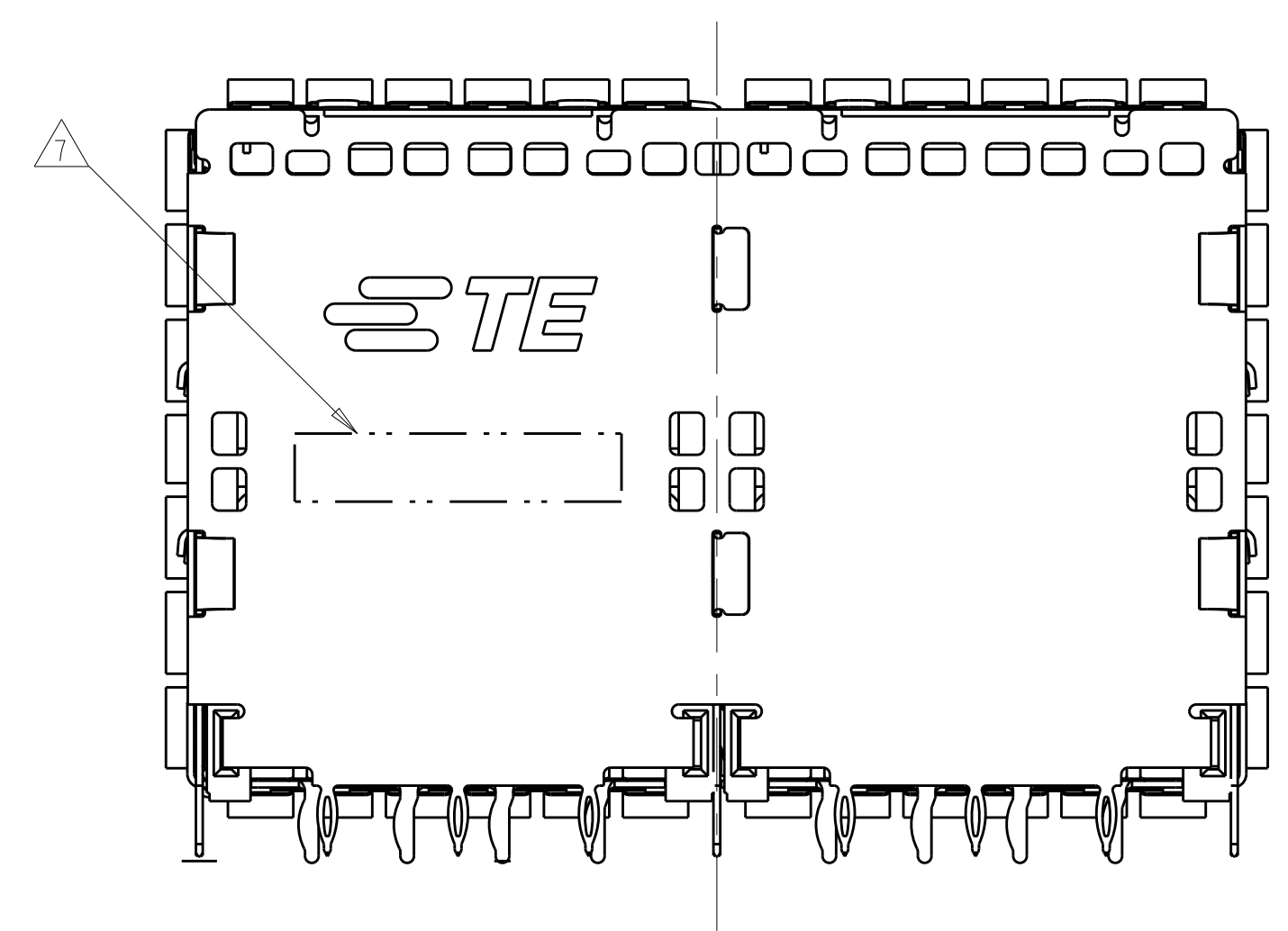

VIEW Y-Y

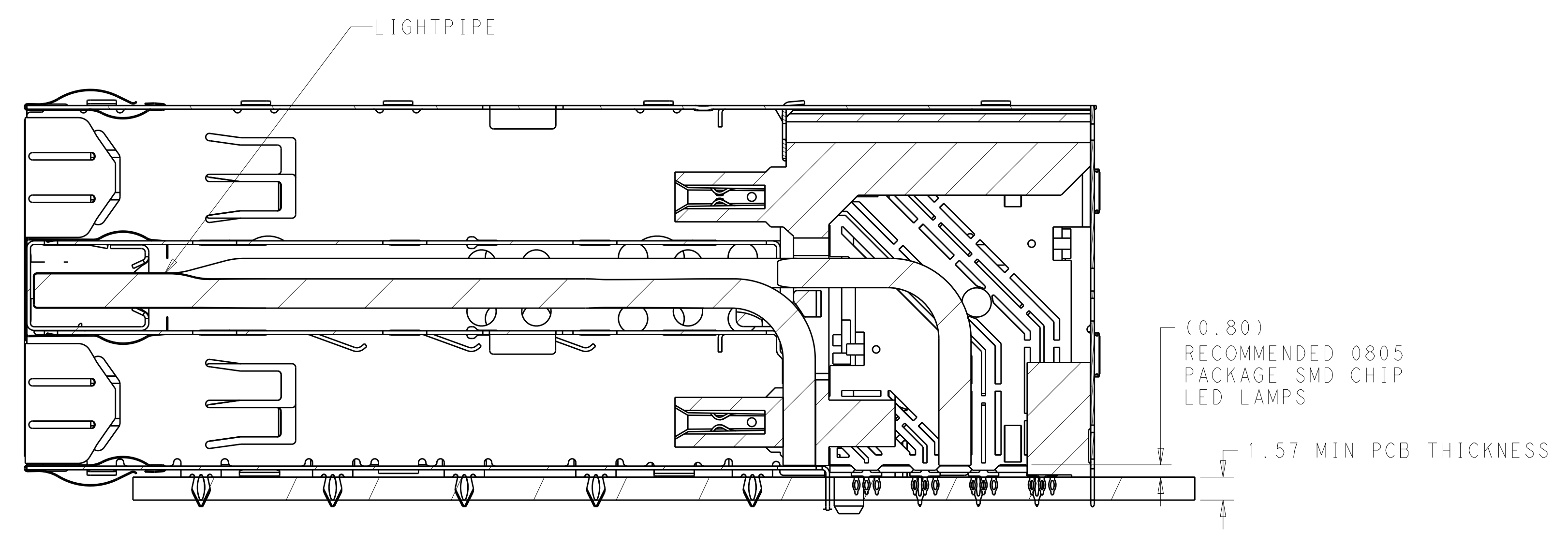

SECTION V-V
SCALE 4:1

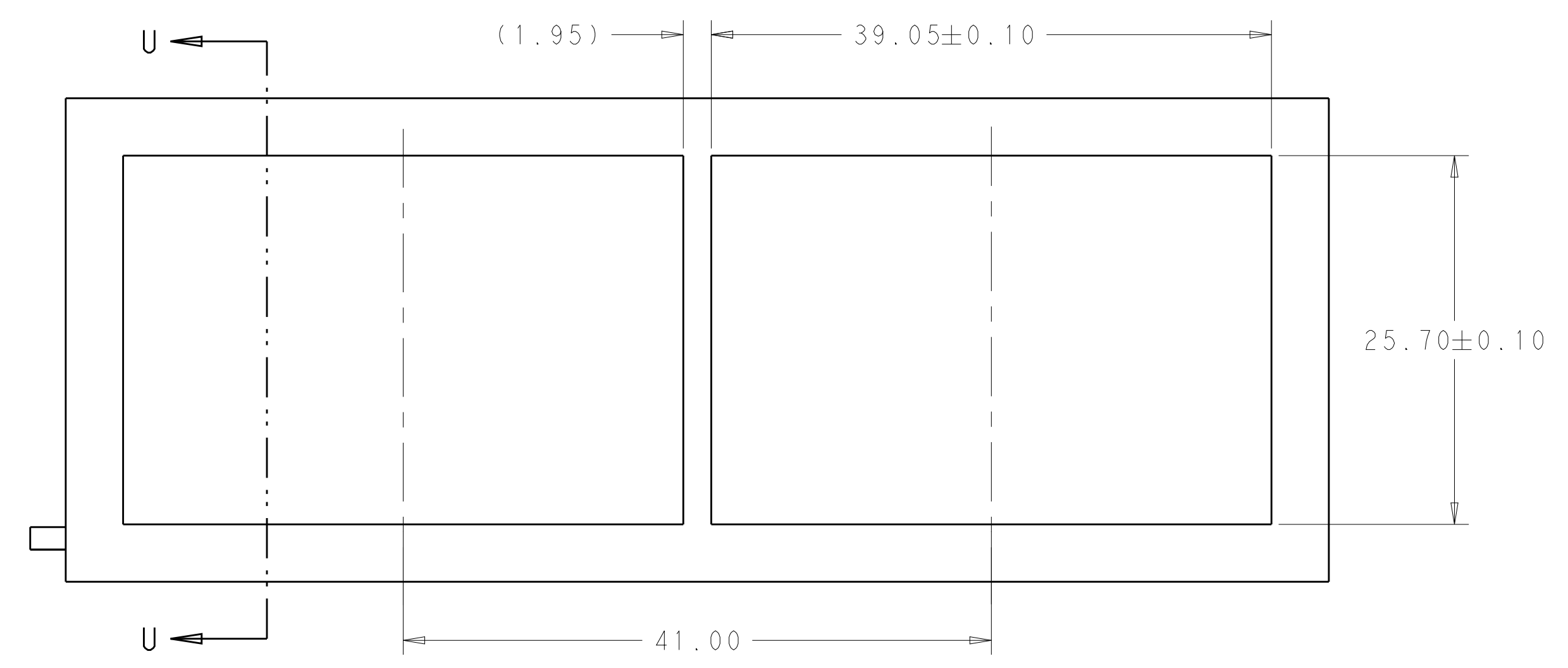

RECOMMENDED PANEL CUTOUT
AND PC BOARD, PANEL POSITION
SCALE 3:1

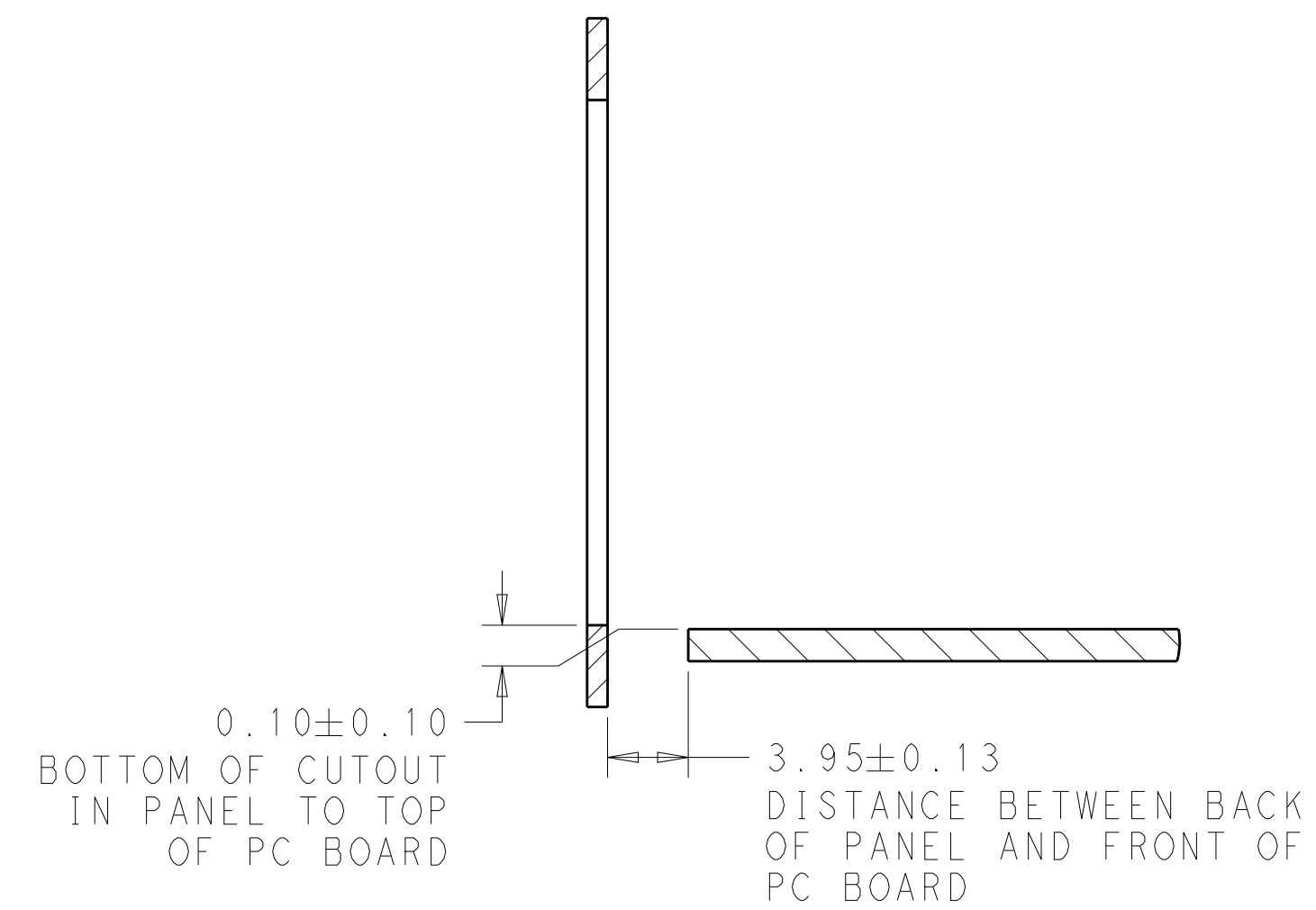

SECTION U-U

THIS DRAWING IS A CONTROLLED DOCUMENT.		OWN: TIM XUE 30NOV2014	TE Connectivity
DIMENSIONS: mm		CHK: JASON YANG 30NOV2014	
TOLERANCES UNLESS OTHERWISE SPECIFIED:		APVD: JASON YANG 30NOV2014	NAME: ZOSFP+ 2X2 WITH EMI SPRING FINGERS 4 INTERNAL LIGHT PIPES
0 PLC ±	1 PLC ±0.25	PRODUCT SPEC: 108-60102	SIZE: A1
2 PLC ±0.15	3 PLC ±	APPLICATION SPEC: 114-60015	CAGE CODE: 2289129
4 PLC ±	ANGLES ±	WEIGHT: -	RESTRICTED TO: -
MATERIAL: -	FINISH: -	CUSTOMER DRAWING	SCALE: 4:1 SHEET: 4 OF 6 REV: E
SEE NOTE 1	SEE NOTE 2		

REVISIONS				
P.	LTN.	DESCRIPTION	DATE	APP'D.
-	-	SEE SHEET 1	-	-

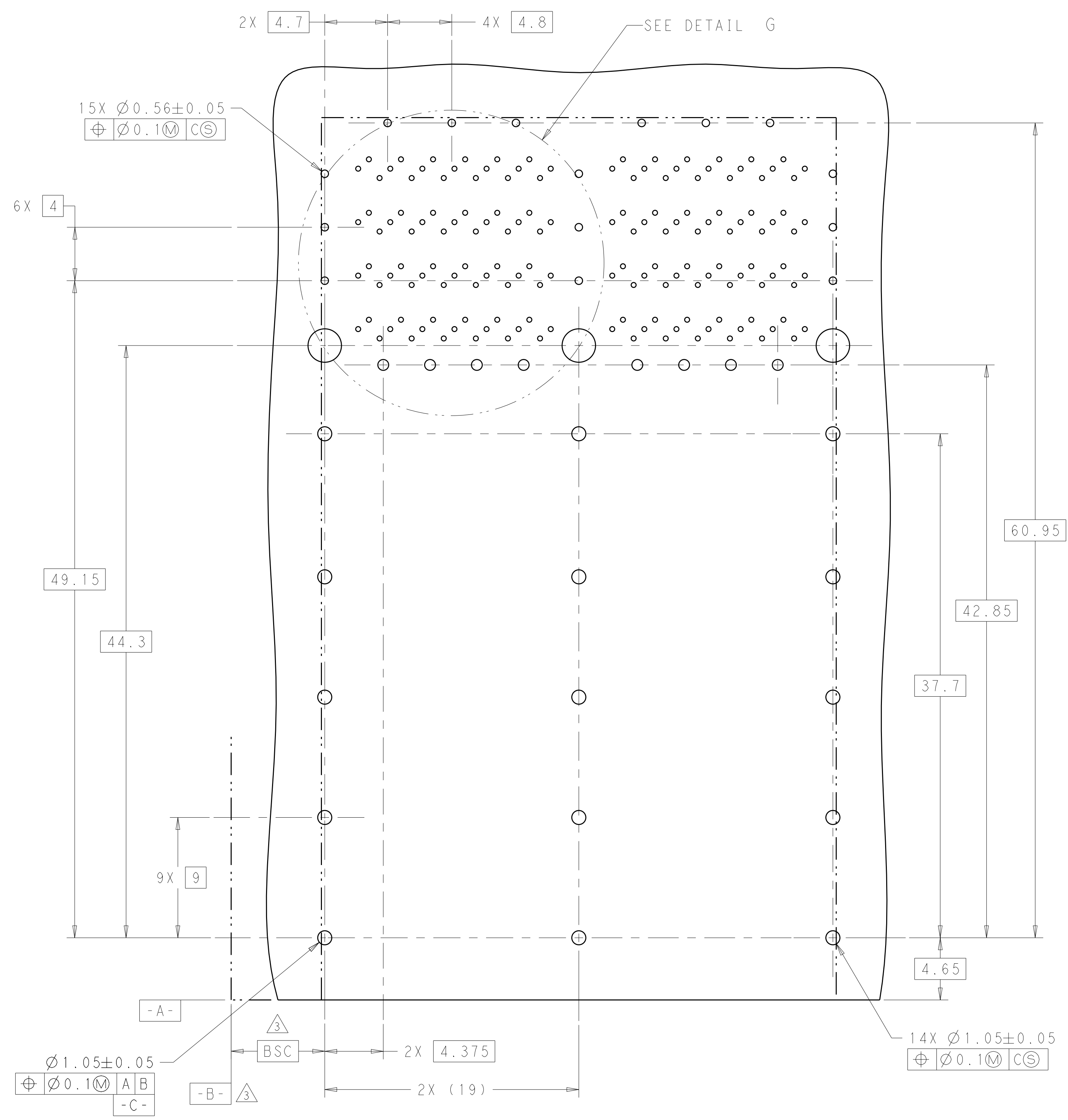

RECOMMENDED PCB BOARD LAYOUT
COMPONENT SIDE OF BOARD
(PCB TOLERANCE ±0.05)
SCALE 5:1

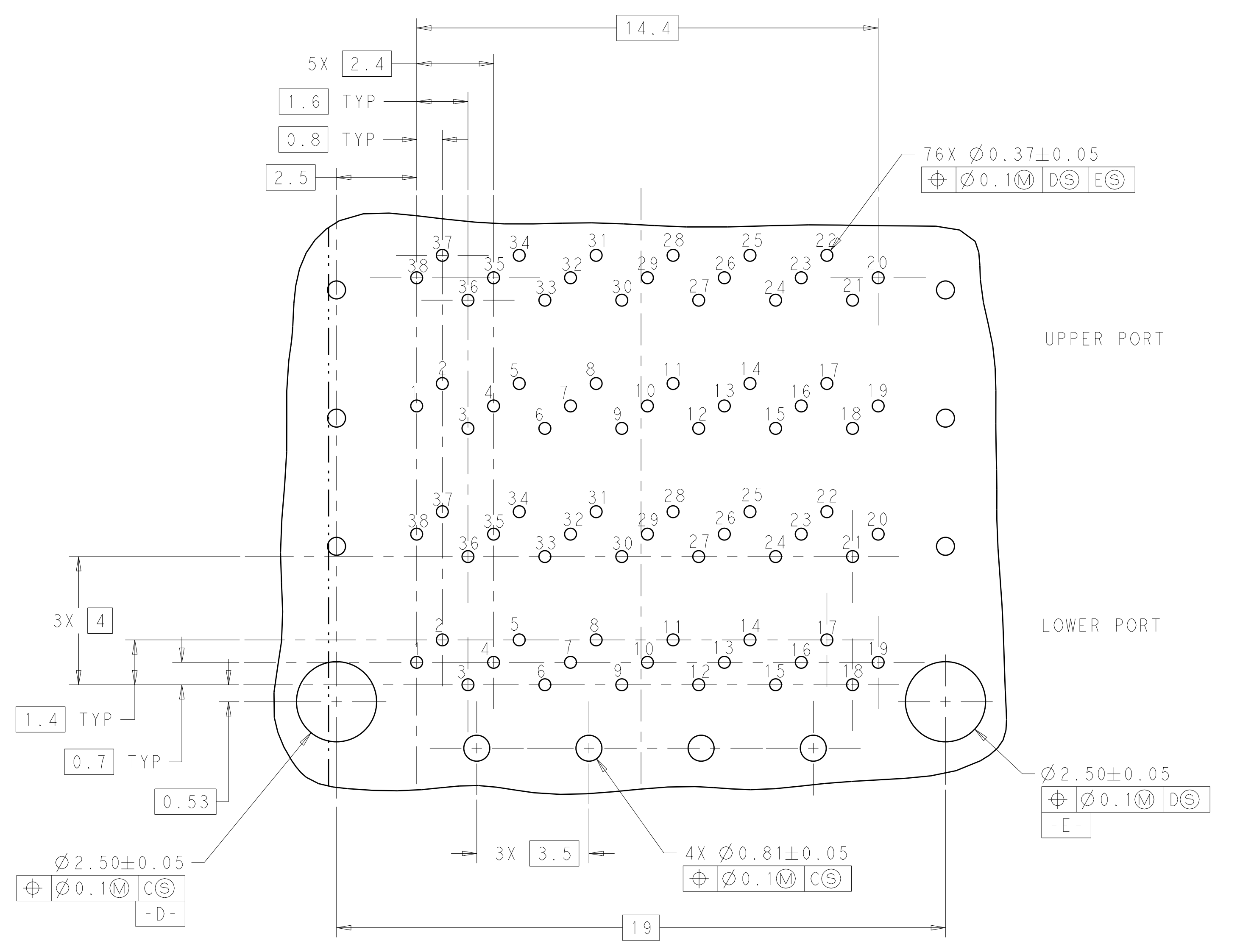

DETAIL G
SCALE 10:1

THIS DRAWING IS A CONTROLLED DOCUMENT.		OWN: TIM XUE 30NOV2014	 TE Connectivity
DIMENSIONS: mm		CHK: JASON YANG 30NOV2014	
TOLERANCES UNLESS OTHERWISE SPECIFIED:		APP'D: JASON YANG 30NOV2014	NAME: ZOSFP+ 2X2 WITH EMI SPRING FINGERS
0 PLC ±0.25	1 PLC ±0.15	PRODUCT SPEC: 108-60102	4 INTERNAL LIGHT PIPES
2 PLC ±0.15	3 PLC ±0.15	APPLICATION SPEC: 114-60015	SIZE: A1
4 PLC ±0.15	ANGLES ±0.15	WEIGHT: -	CAGE CODE: 2289129
MATERIAL: -	FINISH: -	CUSTOMER DRAWING	SCALE: 1:1 SHEET 5 OF 6 REV E

REVISIONS				
P.	LTN.	DESCRIPTION	DATE	APPD.
-	-	SEE SHEET 1	-	-

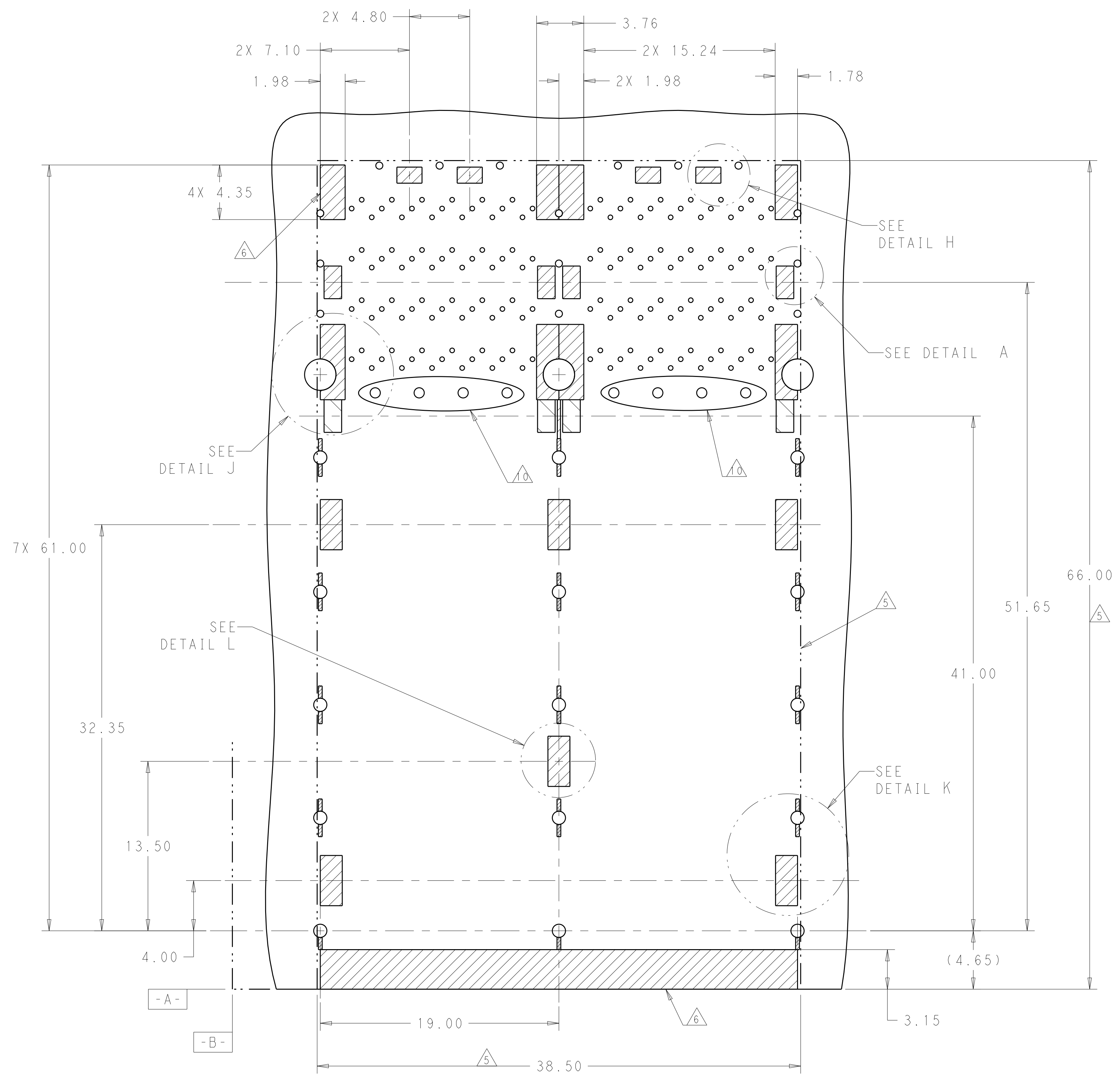

KEEPOUT AREAS
COMPONENT SIDE OF BOARD
(PCB TOLERANCE ±0.05)
SCALE 5:1

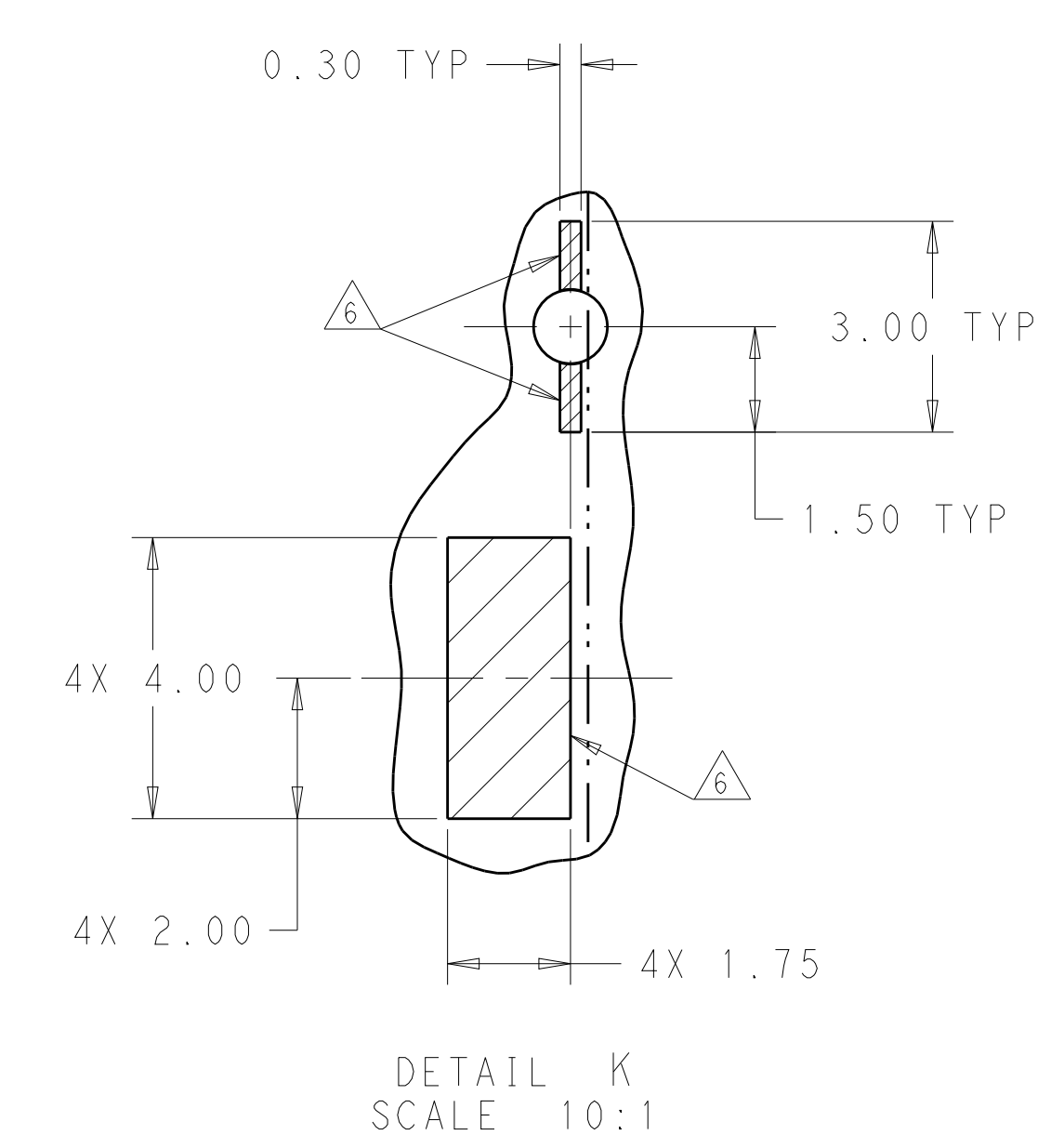
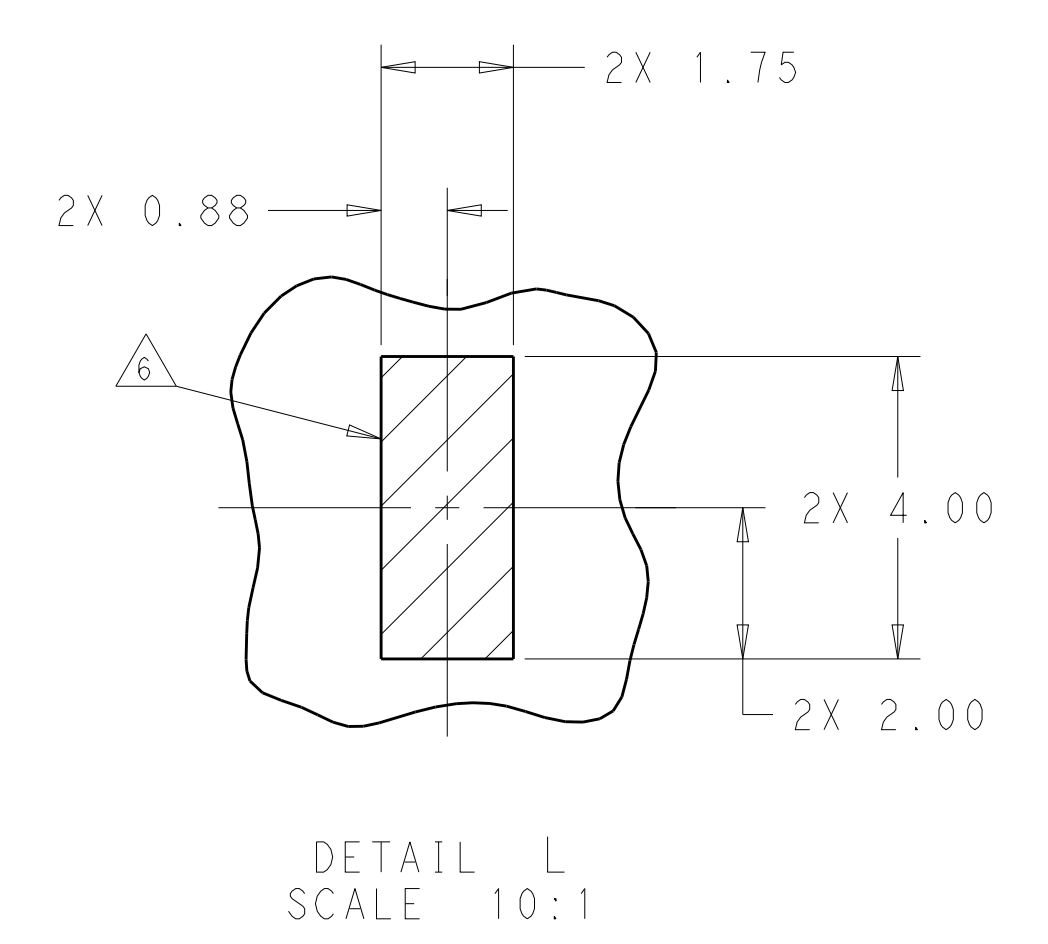
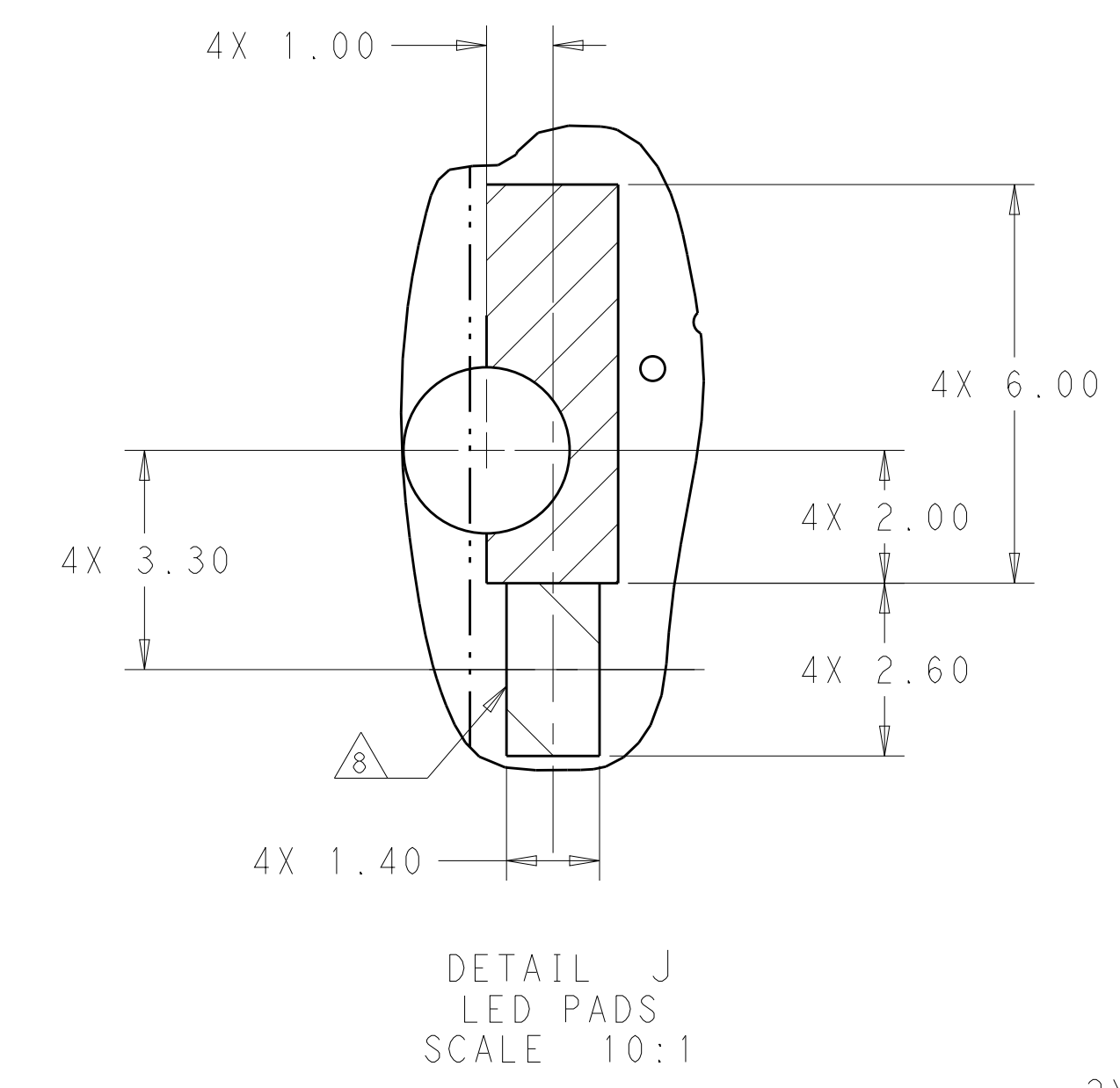
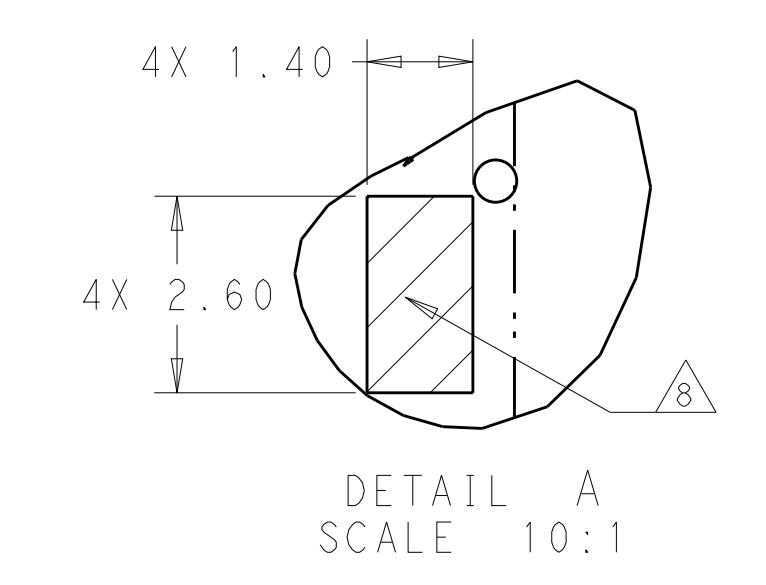
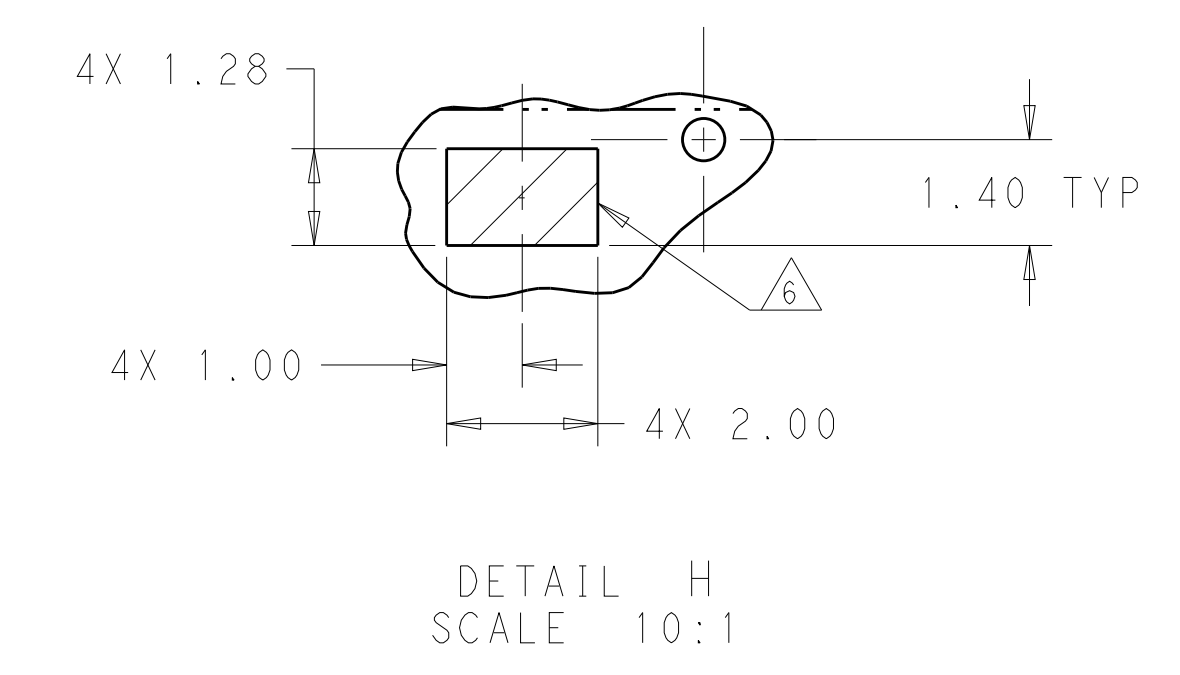

THIS DRAWING IS A CONTROLLED DOCUMENT.		OWN: TIM XUE 30NOV2014	 TE Connectivity
DIMENSIONS: mm		CHK: JASON YANG 30NOV2014	
TOLERANCES UNLESS OTHERWISE SPECIFIED:		APVD: JASON YANG 30NOV2014	NAME: ZOSFP+ 2X2 WITH EMI SPRING FINGERS 4 INTERNAL LIGHT PIPES
0 PLC ±0.25		PRODUCT SPEC: 108-60102	SIZE: 114-60015
1 PLC ±0.15		APPLICATION SPEC: 114-60015	RESTRICTED TO: A100779C=2289129
2 PLC ±0.10		WEIGHT: -	SCALE: 1:1
3 PLC ±0.05		CUSTOMER DRAWING	SHEET 6 OF 6
4 PLC ±0.02			REV E
ANGLES ±0.1			

单击下面可查看定价，库存，交付和生命周期等信息

[>>TE Connectivity\(泰科\)](#)