

REVISIONS				
P	LTR	DESCRIPTION	DATE	APPV
1		SEE SHEET 1	-	-

1. MATERIAL:
 CAGE MATERIAL : 0.25 THICK NICKEL SILVER,
 CRADLE MATERIAL: PC UL 94 V-0;
 SPRING MATERIAL: COPPER ALLOY
 HEAT SINK MATERIAL: ALUMINUM
 CLIP MATERIAL: STAINLESS STEEL
2. FINISH:
 SPRING: NICKEL PLATING
 HEAT SINK: BLACK ANODIZE
- △ DIMENSION APPLIES WITH MODULE INSTALLED IN THE CAGE TO TOP OF HEAT SINK.
- △ REFERENCE APPLICATION SPEC 114-32023 FOR RECOMMENDED DRILL HOLE DIAMETER AND PLATING THICKNESS.
- △ DATUM AND BASIC DIMENSIONS ESTABLISHED BY CUSTOMERS.
6. MINIMUM PC BOARD THICKNESS : SINGLES SIDED: 1.57 MIN
 DOUBLE SIDED: 2.20 MIN
- △ DATUM A IS TOP SURFACE OF THE HOST BOARD.
- △ DATE CODE (YYWWD) MARKED APPROXIMATELY AS SHOWN
9. MATES WITH QSFP28 MSA COMPATIBLE TRANSCEIVER.

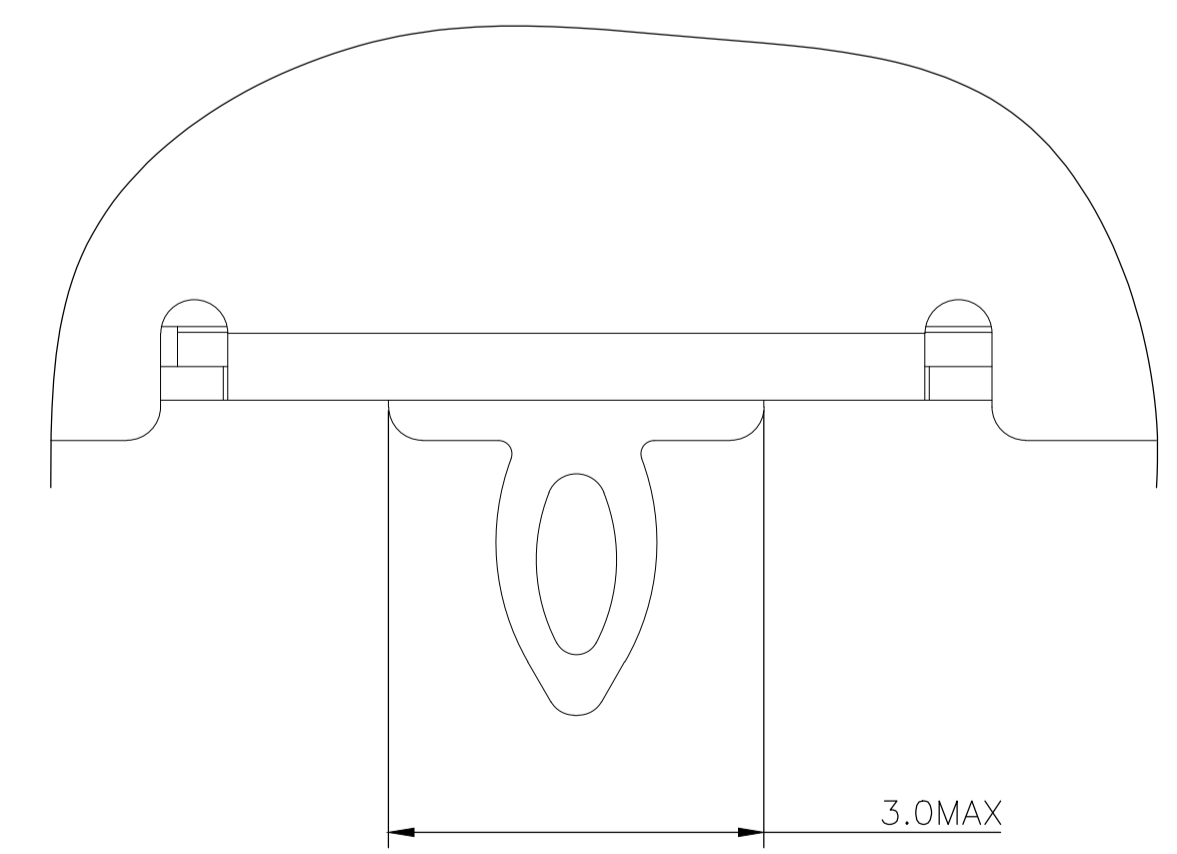
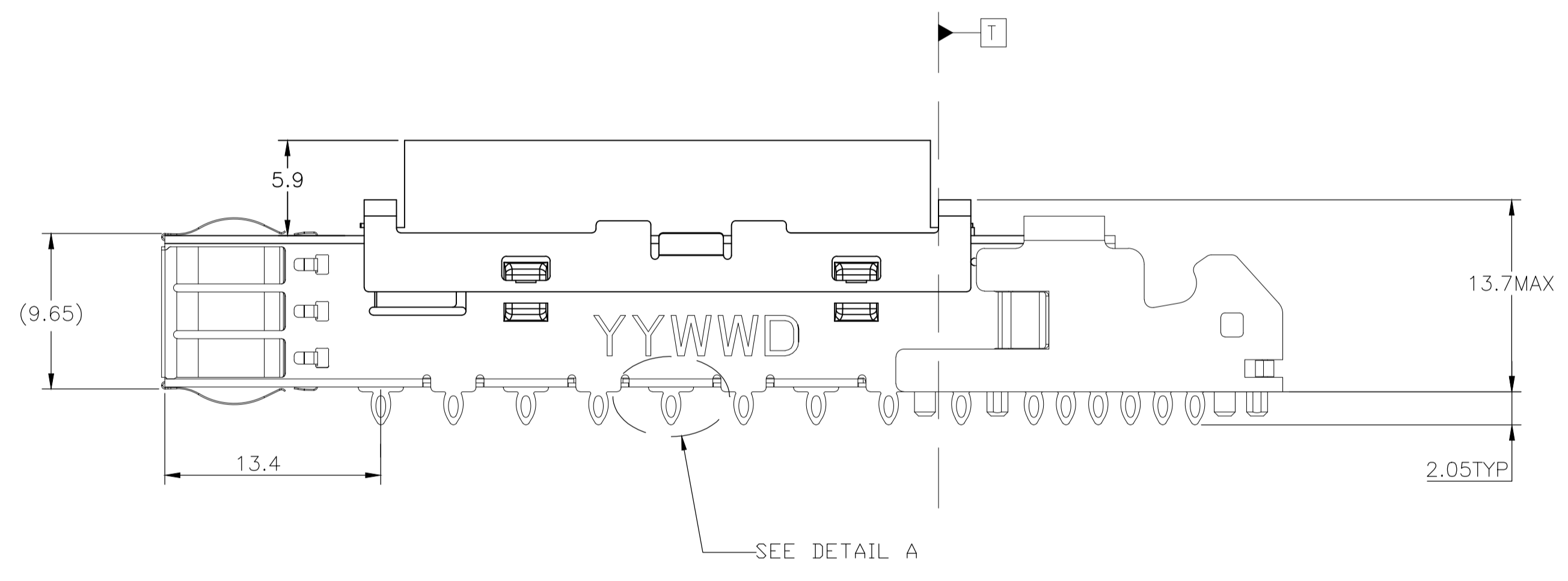
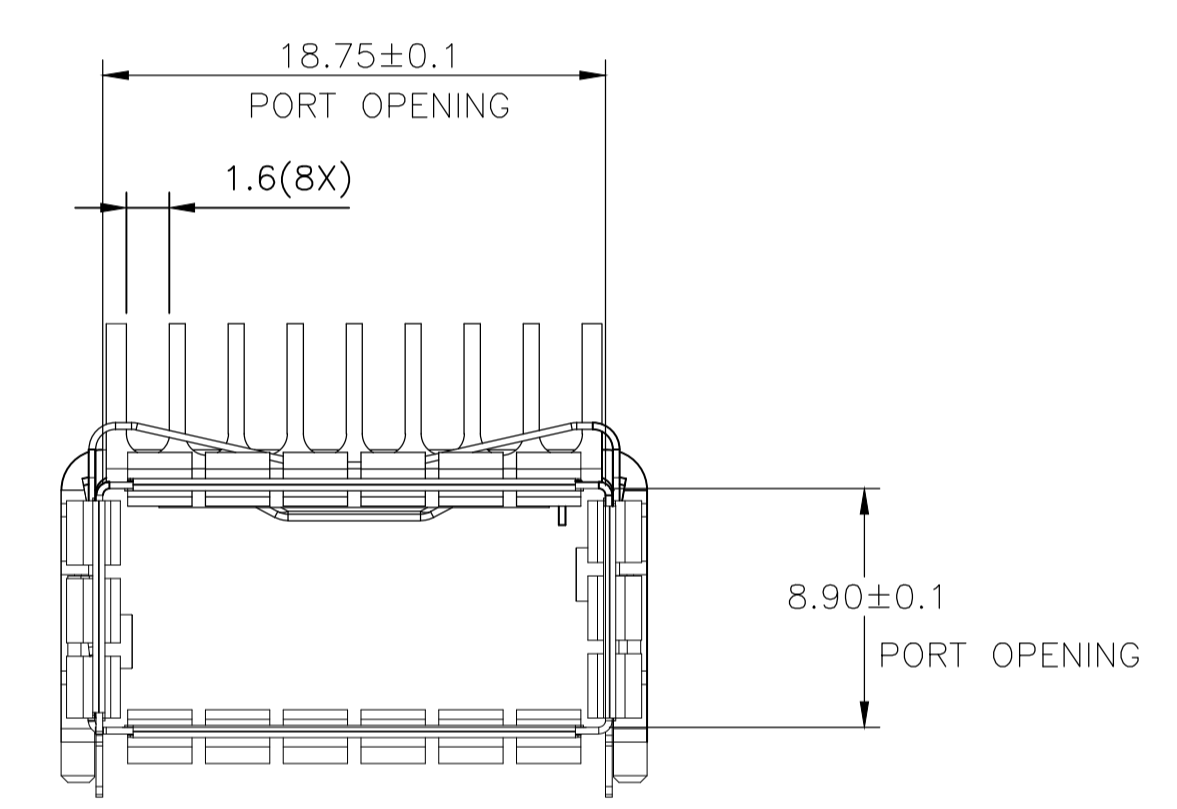
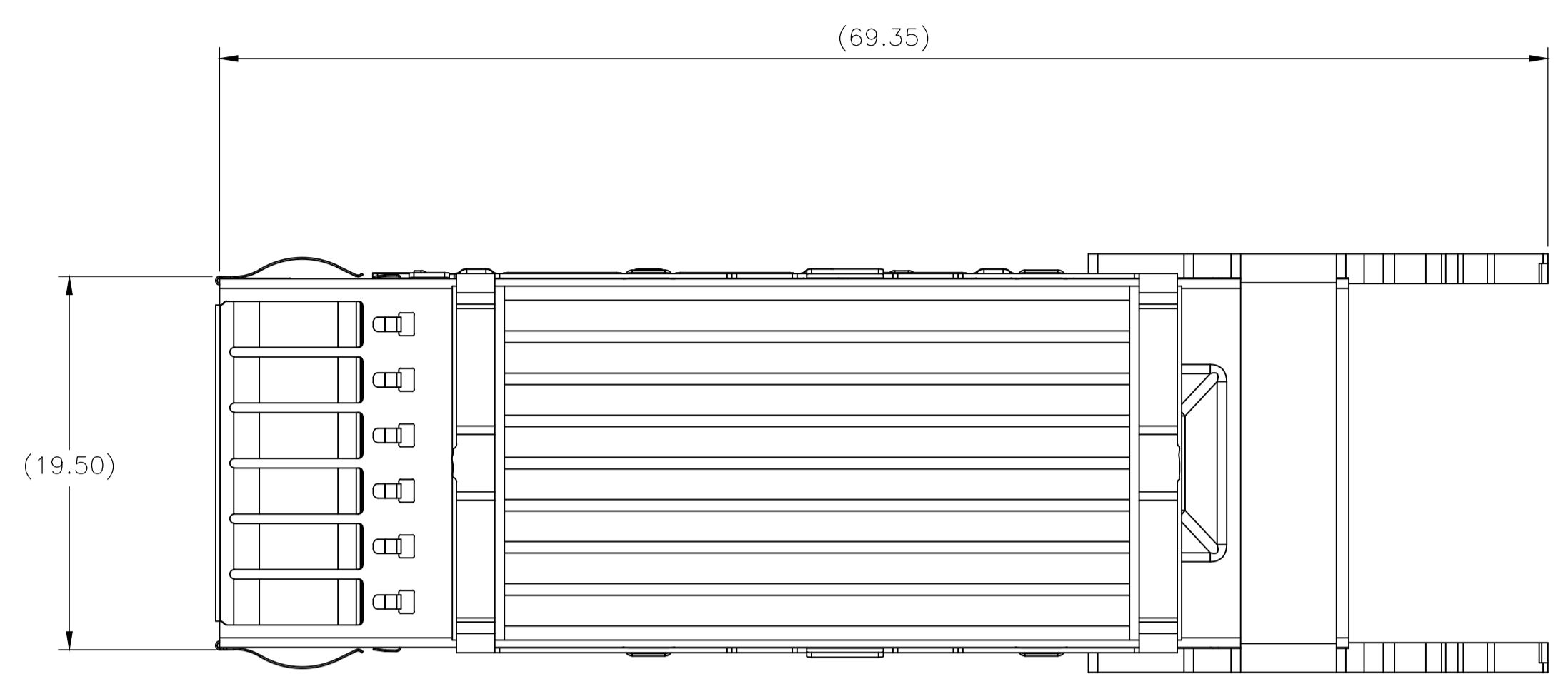

DETAIL A
 SCAEL 20:1

2366599-1
 TE P/N

THIS DRAWING IS A CONTROLLED DOCUMENT.		DIN: GARNETT WU CHK: DAVID ZHANG APVD: DAVID ZHANG NAME: DAVID ZHANG	NOV2019 NOV2019 NOV2019	TE Connectivity	
DIMENSIONS: mm TOLERANCES UNLESS OTHERWISE SPECIFIED: 0 PLC ± - 1 PLC ± - 2 PLC ± - 3 PLC ± - 4 PLC ± - ANGLES ± -		NAME: CAGE ASSEMBLY, QSFP OTB WITH HEAT SINK AND CLIP PRODUCT SPEC: - APPLICATION SPEC: -	SIZE: A1 CAGE CODE: 00779 DRAWING NO: C=2366599	RESTRICTED TO: - WEIGHT: 0 CUSTOMER DRAWING	
MATERIAL: -		FINISH: -		SCALE: 4:1	SHEET 1 OF 3

REVISIONS				
P	LTR	DESCRIPTION	DATE	APP'D
-	-	SEE SHEET 1	-	-

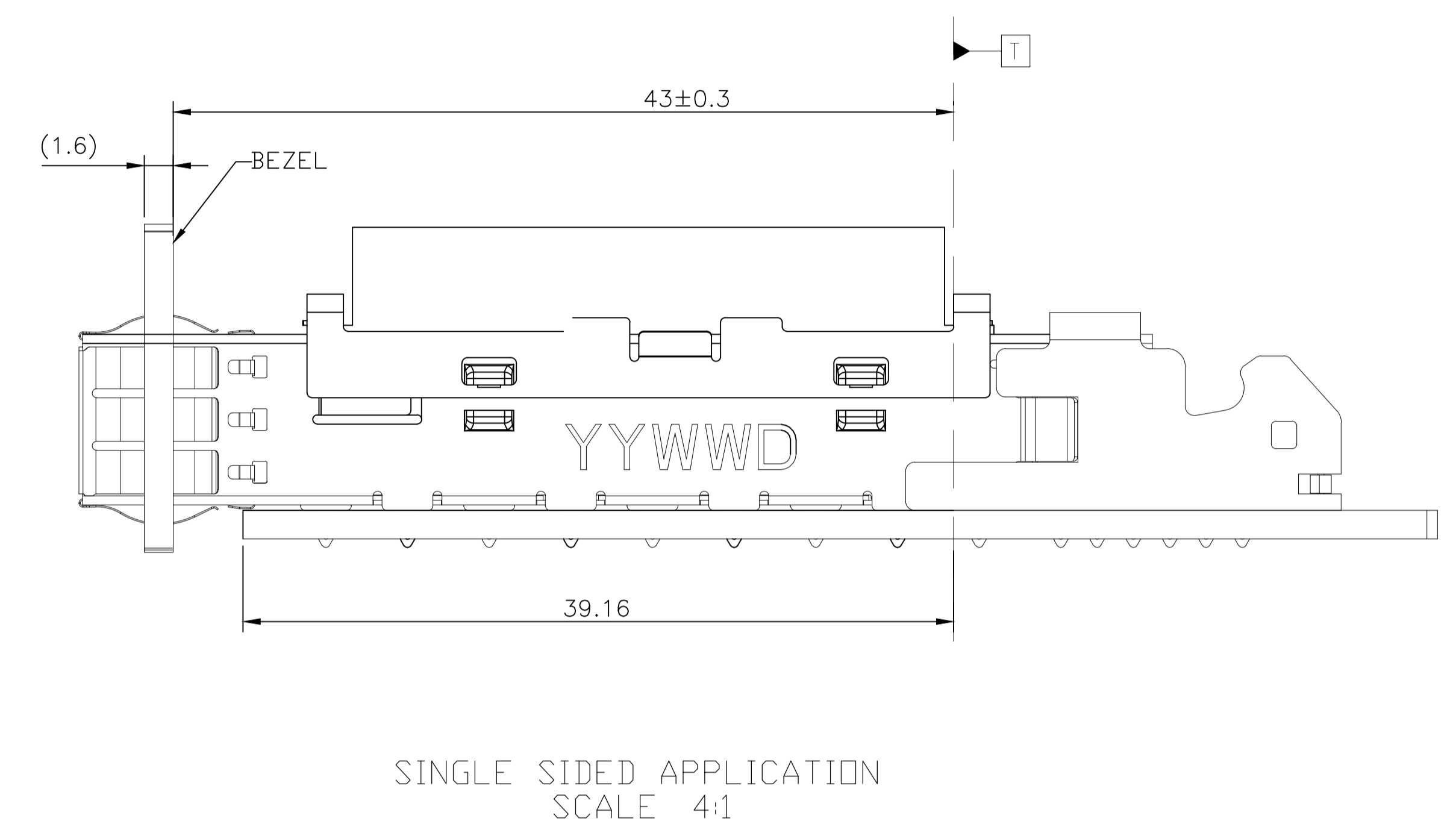
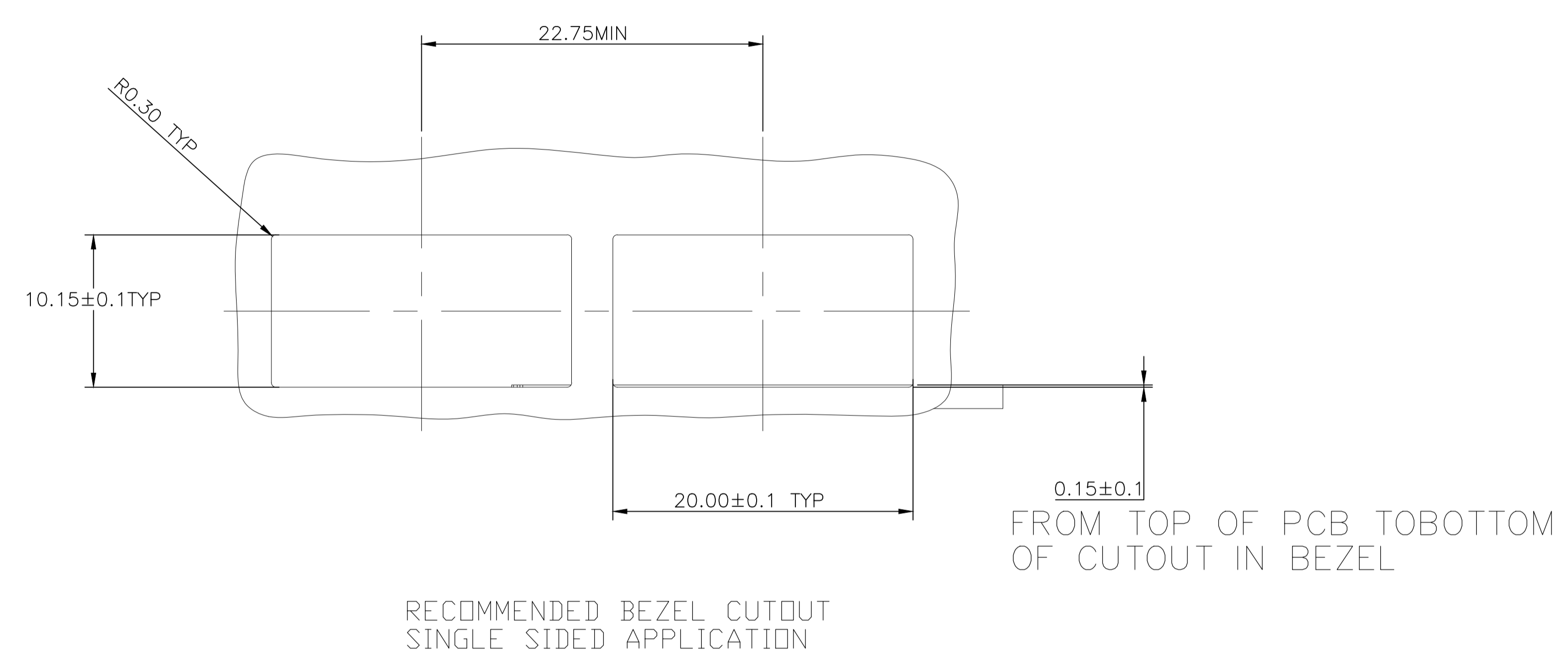

THIS DRAWING IS A CONTROLLED DOCUMENT.		DWG: GARNETT WU CHK: DAVID ZHANG APP'D: DAVID ZHANG	BDEC2019 BDEC2019 BDEC2019	TE Connectivity	
DIMENSIONS:	TOLERANCES UNLESS OTHERWISE SPECIFIED:	NAME:	PRODUCT SPEC:	CAGE ASSEMBLY, QSFP OTB WITH HEAT SINK AND CLIP	
mm	0 PLC ± - 1 PLC ± - 2 PLC ± - 3 PLC ± - 4 PLC ± - ANGLES ± -	APPLICATION SPEC:	SIZE:	CAGE CODE:	DRAWING NO:
MATERIAL:	FINISH:	WEIGHT:	A1	00779	2366599
CUSTOMER DRAWING			SCALE:	SHEET:	REV:
			4:1	2 OF 3	1

REVISIONS				
P	LTR	DESCRIPTION	DATE	APPV
-	-	SEE SHEET 1	-	-

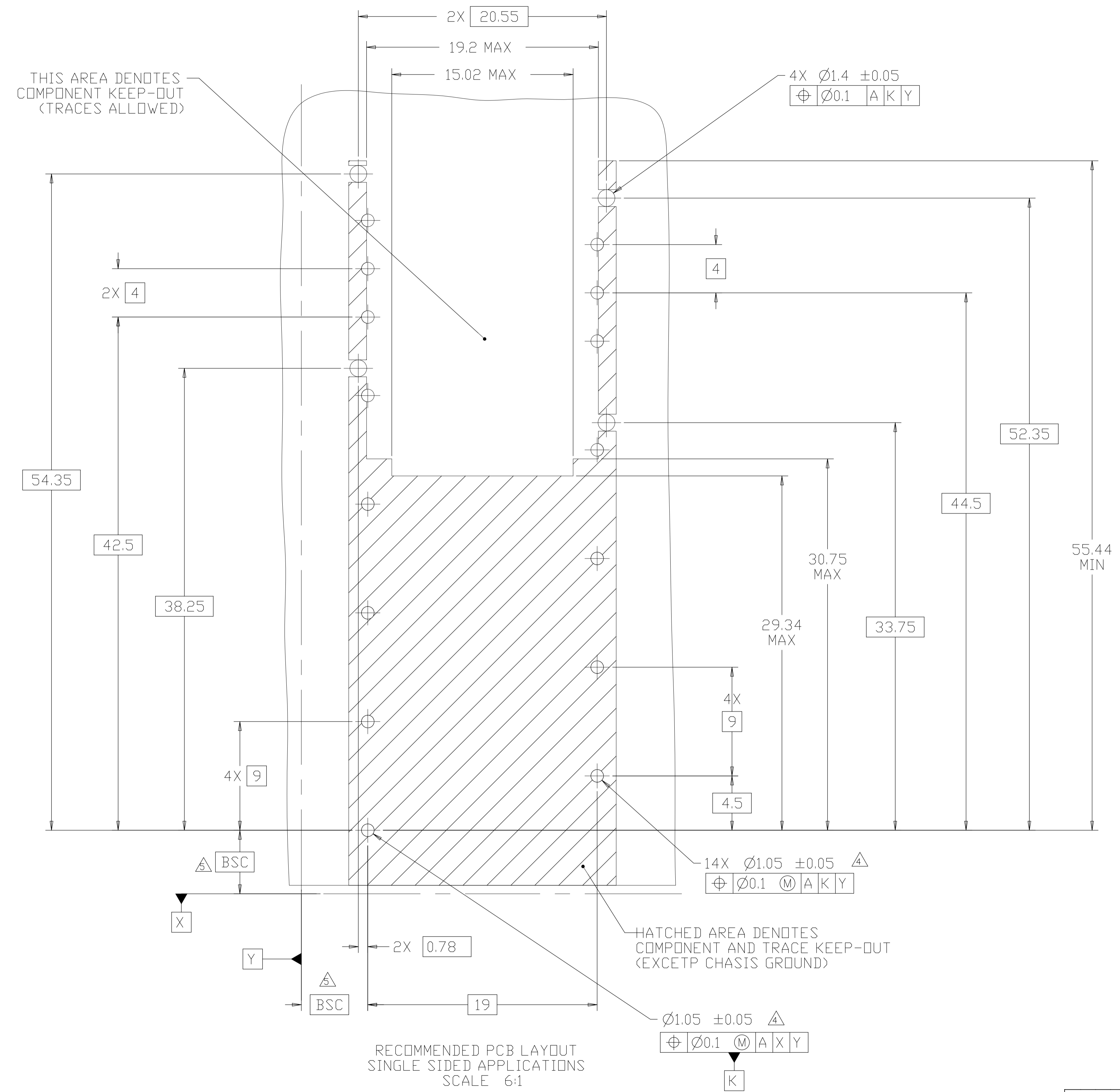

THIS DRAWING IS A CONTROLLED DOCUMENT.		DWG: GARNETT WU	BDEC2019	STE TE Connectivity	
		CHK: DAVID ZHANG	BDEC2019		
DIMENSIONS: mm		TOLERANCES UNLESS OTHERWISE SPECIFIED:		NAME: CAGE ASSEMBLY, QSFP OTB WITH HEAT SINK AND CLIP	
0 PLC ± -		1 PLC ± -		PRODUCT SPEC: -	
2 PLC ± -		3 PLC ± -		APPLICATION SPEC: -	
3 PLC ± -		4 PLC ± -		SIZE: A1	
4 PLC ± -		ANGLES ± -		CAGE CODE: 00779	
MATERIAL: -		FINISH: -		DRAWING NO: 2366599	
		WEIGHT: 0		RESTRICTED TO: -	
		CUSTOMER DRAWING		SCALE: 4:1 SHEET 3 OF 3 REV 1	

单击下面可查看定价，库存，交付和生命周期等信息

[>>TE Connectivity\(泰科\)](#)