

THIS DRAWING IS UNPUBLISHED. RELEASED FOR PUBLICATION
 © COPYRIGHT - By - ALL RIGHTS RESERVED.

LOC	DIST	REVISIONS					
G	14	P	LTR	DESCRIPTION	DATE	DWN	APVD
		E1		REVISED PER ECO-11-004917	11MAR11	RK	HMR

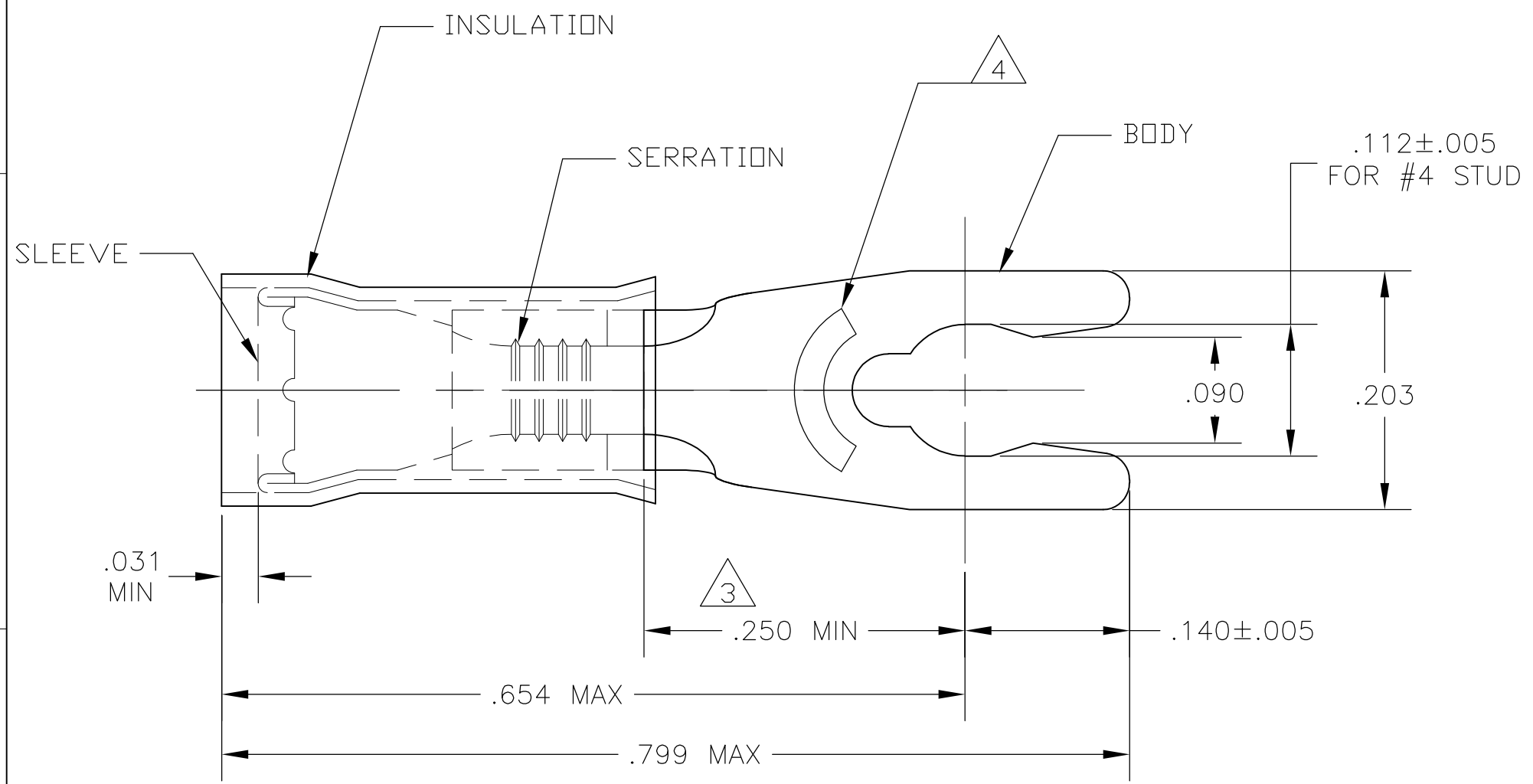

- 1 FOR .080-.125 WIRE INSULATION DIA
- 2 TONGUE MATERIAL THK = .031 ± .002
- 3 APPLIES FROM THE METAL EDGE OF THE BARREL TO THE CENTER OF THE STUD
- 4 MARKING 22-18 FOR MILITARY, COMMERCIAL RANGE 22-16

100	LOOSE PIECE, BOX	BODY: PHOS BRONZE PER ASTM-B103 TIN PLATE PER ASTM-B545 SLEEVE: COPPER PER ASTM-B152 INSULATION: NYLON PER ASTM-D4066 TYPE 1, COLOR: RED	8-52927-1
5,000	52927 ON TAPE		52927-1
1	WIRE TERMINAL		52927
QTY	DESCRIPTION	MATERIAL & FINISH	PART NO

THIS DRAWING IS A CONTROLLED DOCUMENT.		DWN jr_ruth 09MAR10	STE TE Connectivity	
DIMENSIONS: INCHES		CHK TOM MICHIELUTTI 09MAR10		
TOLERANCES UNLESS OTHERWISE SPECIFIED:		APVD TOM MICHIELUTTI 09MAR10	NAME WIRE TERMINAL, PIDG, SPRING SPADE WIRE SIZE: 22-16	
0 PLC ± - 1 PLC ± - 2 PLC ± .008 3 PLC ± - 4 PLC ± - ANGLES ± 5°		PRODUCT SPEC -	SIZE A3	
MATERIAL SEE TABLE		APPLICATION SPEC -	CAGE CODE 00779	DRAWING NO C-52927
FINISH SEE TABLE		WEIGHT -	RESTRICTED TO -	
CUSTOMER DRAWING			SCALE 8:1	SHEET 1 OF 1
			REV E1	

单击下面可查看定价，库存，交付和生命周期等信息

[>>TE Connectivity\(泰科\)](#)