

THIS DRAWING IS UNPUBLISHED. RELEASED FOR PUBLICATION
 © COPYRIGHT BY TYCO ELECTRONICS CORPORATION. ALL RIGHTS RESERVED.

LOC		DIST		REVISIONS			
P	LTR	DESCRIPTION		DATE	DWN	APVD	
	M	ECO-07-017363		08AUG2007	RB	MM	

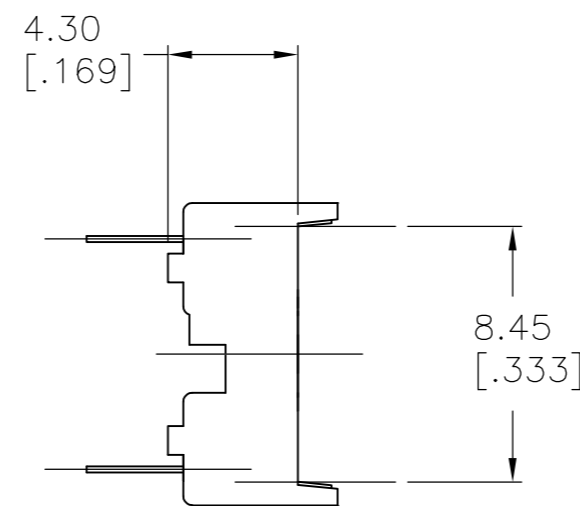
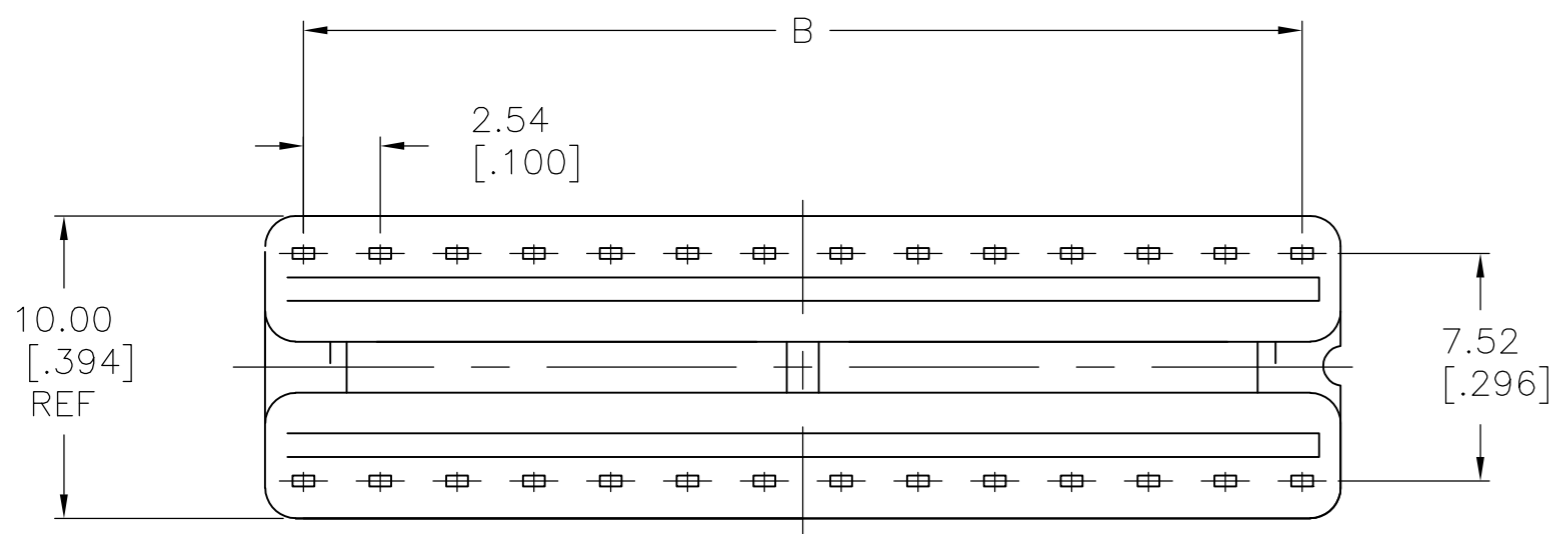
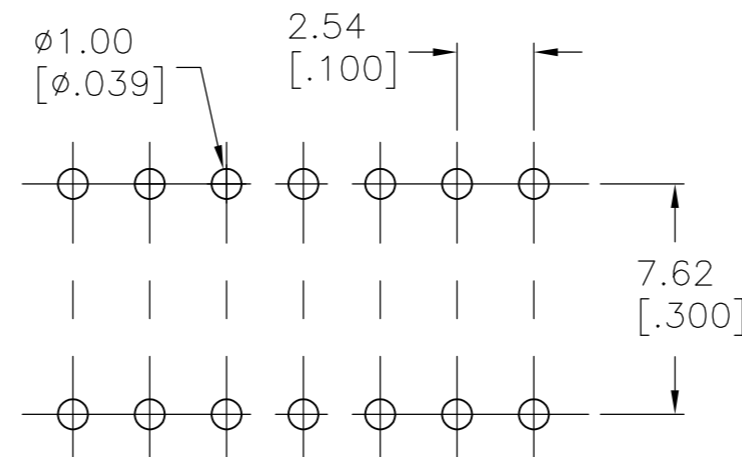
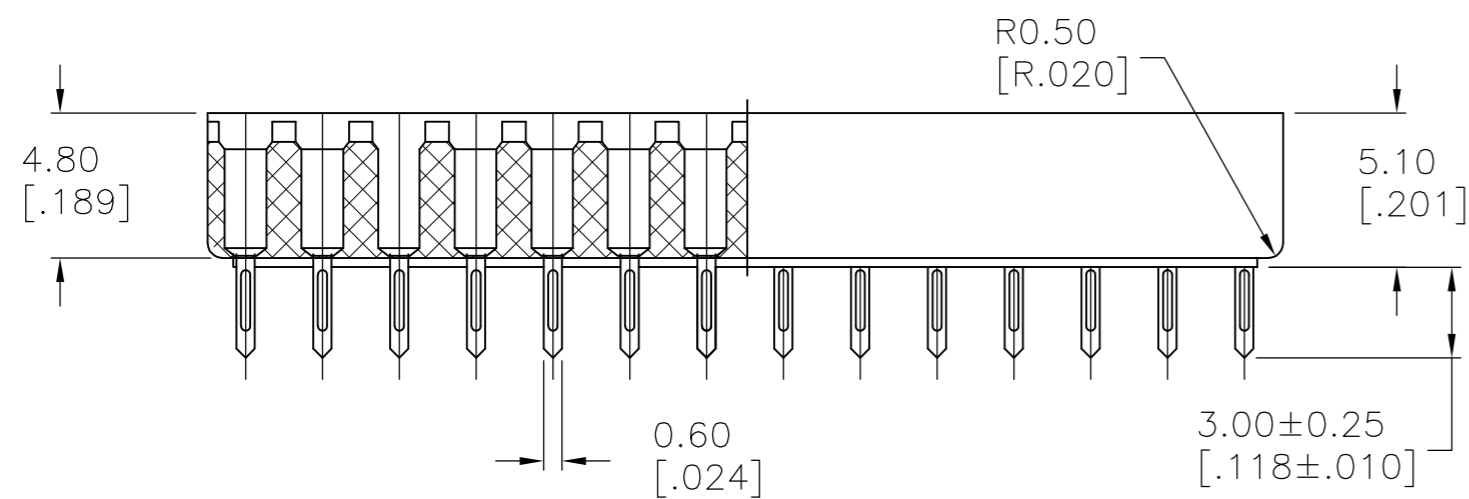
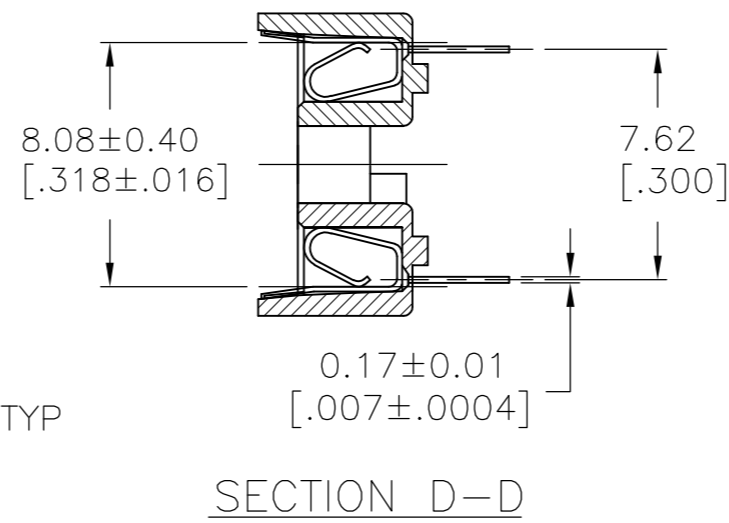
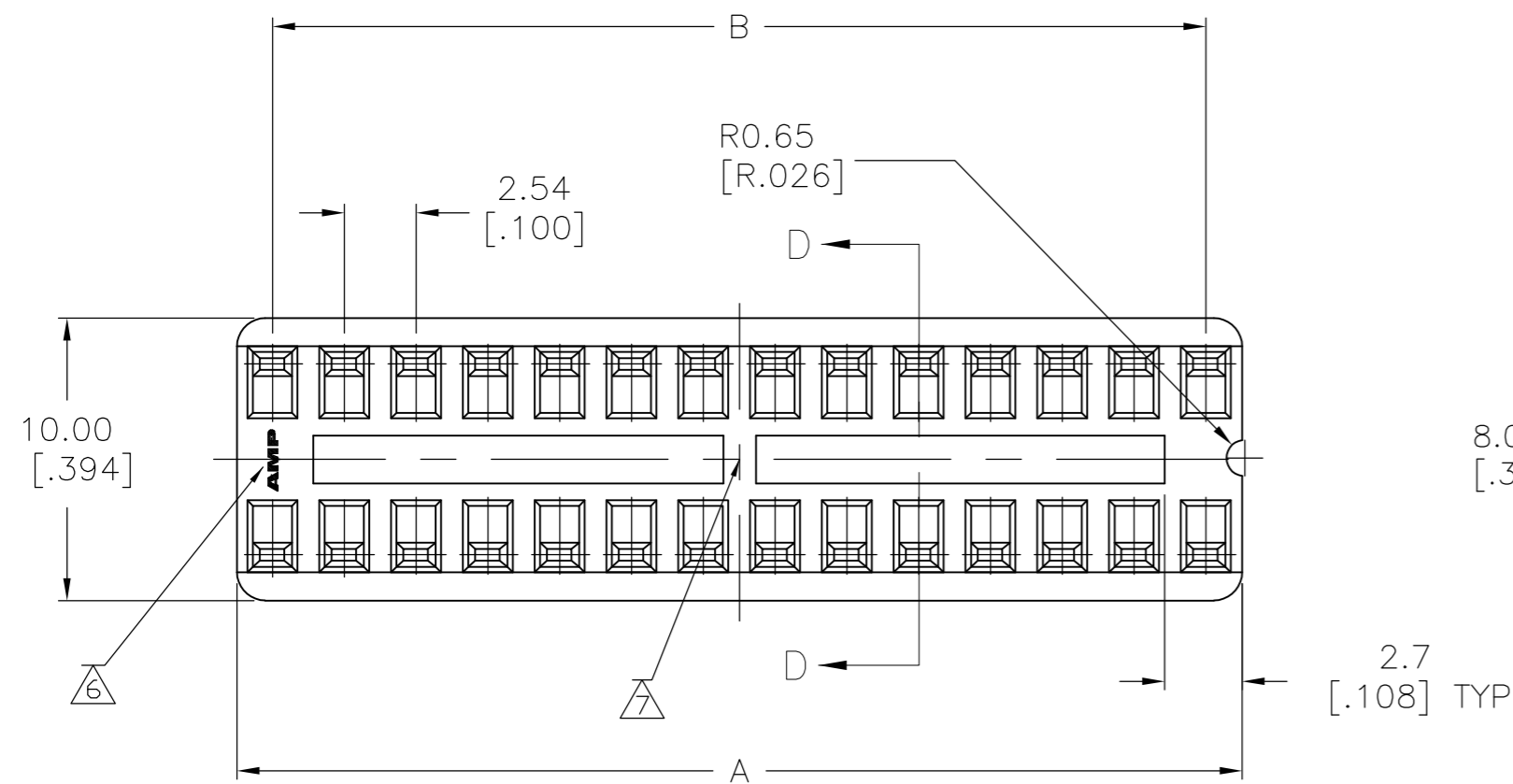

NOTE:

- 1 MATERIAL:
HOUSING: 30% GLASS FILLED PBT, THERMOPLASTIC, BLACK.
CONTACT: PHOS BRONZE
- 2 FINISH: CONTACT PLATING: TIN-LEAD (60u INCHES MIN.)
SOLDERABILITY :95% COVERAGE MIN.;
TEST TEMPERATURE=230°C±5°C
TEST TIME = 5±5 SECONDS.
3. MECHANICAL SPECS:
DURABILITY: 50 CYCLES MIN.
INSERTION FORCE:300 GRAMS MAX.
WITHDRAWAL FORCE: 20 GRAMS MIN.
CONTACT RETENTION: 500 GRAMS MIN.
ACCEPTS: 0.20-0.30 [.008-.012] LEADS
4. ELECTRICAL SPECS:
VOLTAGE RATING: 250V AC,DC
CONTACT RESISTANCE: 20 MILLOHMS MAX.
CURRENT RATING: 1 AMPERE AC,DC
INSULATION RESISTANCE: 1000 MEGOHMS MIN.
DIELECTRIC WITHSTANDING VOLTAGE: AC 1000 V MIN.
5. OPERATING TEMPERATURE: -40°C TO +105°C
- 6 AMP LOGO
- 7 LADDER PRESENT FOR 24, 28 & 32 POSITION SOCKETS.
- 8 FINISH: CONTACT PLATING TIN (LEAD FREE); 60 UIN MIN. OVER 30 UIN Ni
SOLDERABILITY :95% COVERAGE MIN.;
TEST TEMPERATURE=260°±5°C;
TEST TIME = 5±5 SECONDS.

FINISH	POS	A ±0.20 [.008]	B±0.15 [.006]	PART NO.
8	32	40.64 [1.600]	38.10 [1.500]	2-390261-0
8	28	35.56 [1.400]	33.02 [1.300]	1-390261-9
8	24	30.48 [1.200]	27.94 [1.100]	1-390261-8
8	22	27.94 [1.100]	25.40 [1.000]	1-390261-7
8	20	25.40 [1.000]	22.86 [.900]	1-390261-6
8	18	22.86 [.900]	20.32 [.800]	1-390261-5
8	16	20.32 [.800]	17.78 [.700]	1-390261-4
8	14	17.78 [.700]	15.24 [.600]	1-390261-3
8	8	10.16 [.400]	7.62 [.300]	1-390261-2
8	6	7.62 [.300]	5.08 [.200]	1-390261-1
2	32	40.64 [1.600]	38.10 [1.500]	1-390261-0
2	28	35.56 [1.400]	33.02 [1.300]	390261-9
2	24	30.48 [1.200]	27.94 [1.100]	390261-8
2	22	27.94 [1.100]	25.40 [1.000]	390261-7
2	20	25.40 [1.000]	22.86 [.900]	390261-6
2	18	22.86 [.900]	20.32 [.800]	390261-5
2	16	20.32 [.800]	17.78 [.700]	390261-4
2	14	17.78 [.700]	15.24 [.600]	390261-3
2	8	10.16 [.400]	7.62 [.300]	390261-2
2	6	7.62 [.300]	5.08 [.200]	390261-1

SUPERSEDED BY 2-390261-0
 SUPERSEDED BY 1-390261-9
 SUPERSEDED BY 1-390261-8
 SUPERSEDED BY 1-390261-7
 SUPERSEDED BY 1-390261-6
 SUPERSEDED BY 1-390261-5
 SUPERSEDED BY 1-390261-4
 SUPERSEDED BY 1-390261-3
 SUPERSEDED BY 1-390261-2
 SUPERSEDED BY 1-390261-1

THIS DRAWING IS A CONTROLLED DOCUMENT.		DWN	06SEP2004	
DIMENSIONS: mm [INCHES]		CHK	-	
TOLERANCES UNLESS OTHERWISE SPECIFIED:		APVD	-	
0 PLC ± -		PRODUCT SPEC	-	
1 PLC ± -		APPLICATION SPEC	-	
2 PLC ± 0.2 [.008]		WEIGHT	-	
3 PLC ± -		CUSTOMER DRAWING	-	
4 PLC ± -		SCALE	4:1	
ANGLES ± -		SHEET	1 of 1	
FINISH		REV	M	

Tyco Electronics Corporation
 Harrisburg, PA 17105-3608

DIP SOCKET, .300 CENTER LINE
 LADDER STYLE

SIZE: A2 CAGE CODE: 00779 DRAWING NO: C=390261 RESTRICTED TO: -

单击下面可查看定价，库存，交付和生命周期等信息

[>>TE Connectivity\(泰科\)](#)