

THIS DRAWING IS UNPUBLISHED. RELEASED FOR PUBLICATION
 © COPYRIGHT - By - ALL RIGHTS RESERVED.

LOC	DIST	REVISIONS					
AD	39	P	LTR	DESCRIPTION	DATE	DWN	APVD
		K		PLASTIC MATERIAL SUPPLIER CHANGED FOR HOUSING	07MAY2021	SB	KJK

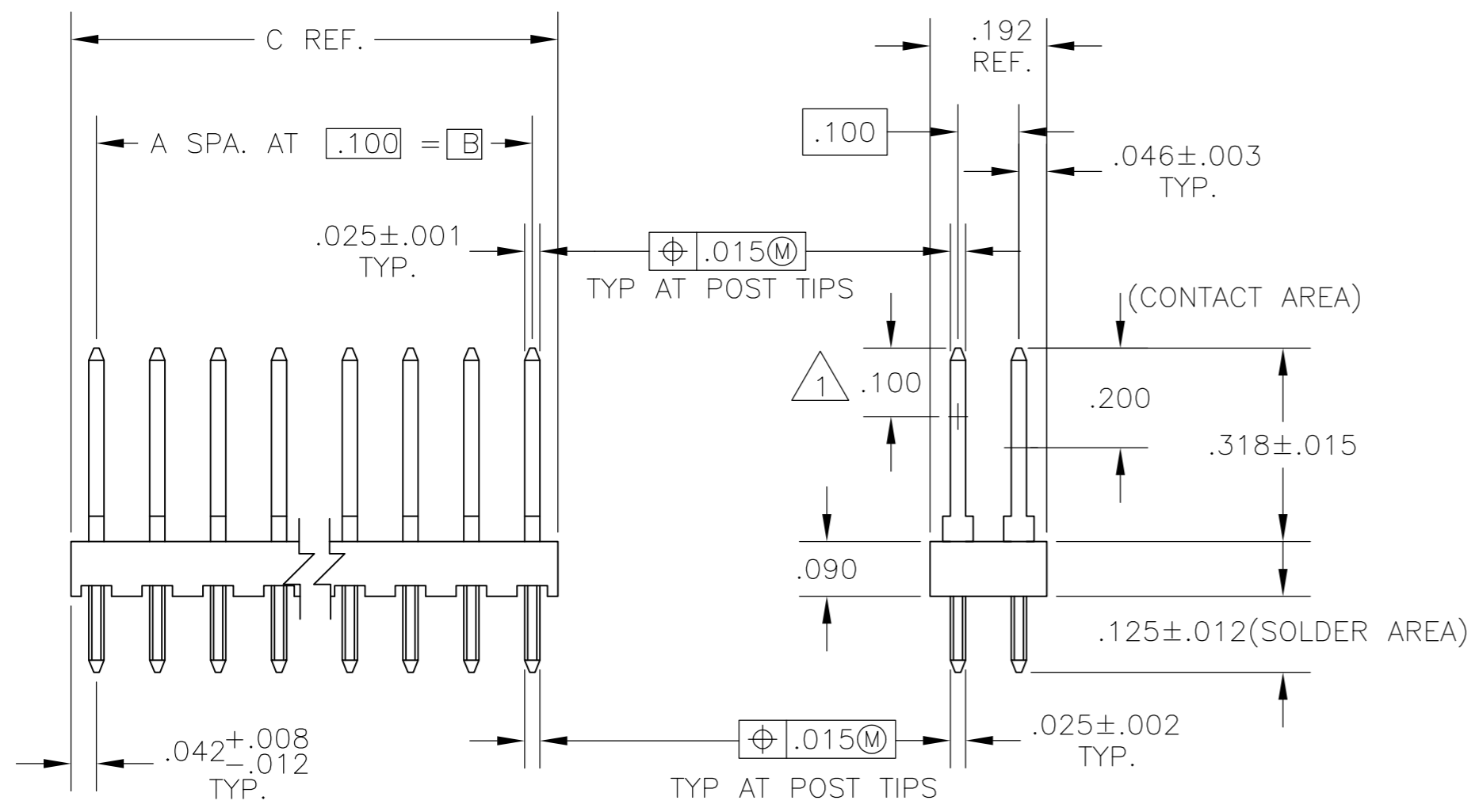

- 1 POINT OF MEASUREMENT FOR PLATING THICKNESS
- 2 THE TRUE POSITION TOLERANCE OF THE POST TIPS APPLIES WHEN THE HEADERS HELD FLAT AGAINST THE PRINTED CIRCUIT BOARD

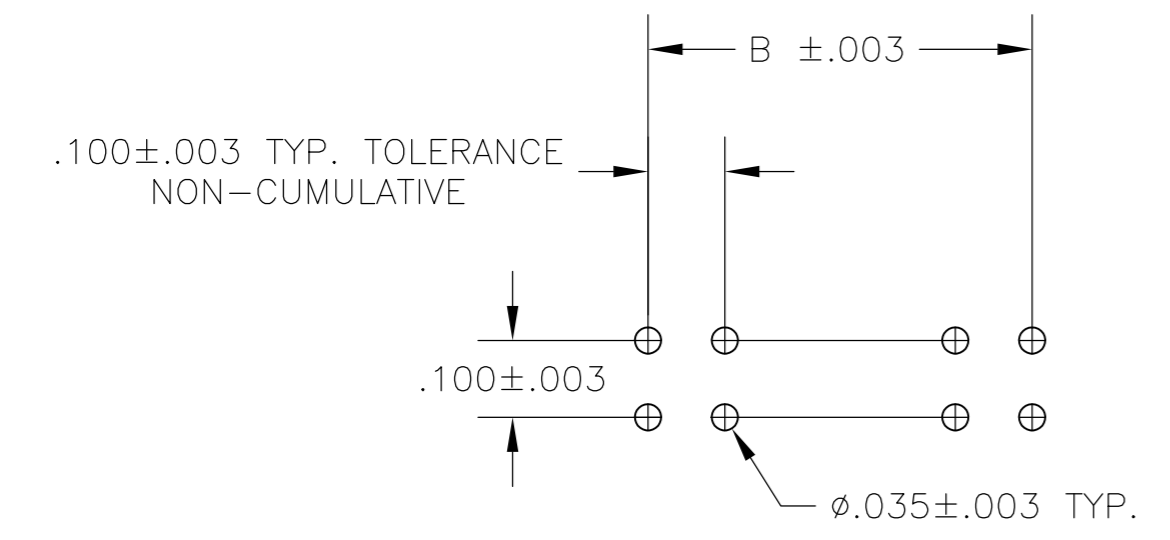

RECOMMENDED HOLE LAYOUT

SDDFSDF

3.984	3.900	39	80	4-87215-0
3.884	3.800	38	78	3-▲-9
3.784	3.700	37	76	3--8
3.684	3.600	36	74	3--7
3.584	3.500	35	72	3--6
3.484	3.400	34	70	3--5
3.384	3.300	33	68	3--4
3.284	3.200	32	66	3--3
3.184	3.100	31	64	3--2
3.084	3.000	30	62	3--1
2.984	2.900	29	60	3--0
2.884	2.800	28	58	2--9
2.784	2.700	27	56	2--8
2.684	2.600	26	54	2--7
2.584	2.500	25	52	2--6
2.484	2.400	24	50	2--5
2.384	2.300	23	48	2--4
2.284	2.200	22	46	2--3
2.184	2.100	21	44	2--2
2.084	2.000	20	42	2--1
1.984	1.900	19	40	2--0
1.884	1.800	18	38	1--9
1.784	1.700	17	36	1--8
1.684	1.600	16	34	1--7
1.584	1.500	15	32	1--6
1.484	1.400	14	30	1--5
1.384	1.300	13	28	1--4
1.084	1.000	10	22	1--3
.284	.200	2	6	1--2
.184	.100	1	4	1--1
.084	---	---	2	1--0
1.284	1.200	12	26	--9
1.184	1.100	11	24	--8
.984	.900	9	20	--7
.884	.800	8	18	--6
.784	.700	7	16	--5
.684	.600	6	14	--4
.584	.500	5	12	--3
.484	.400	4	10	--2
.384	.300	3	8	87215-1
C	B	A	NO OF POS	ASSEMBLY PART NUMBER

THIS DRAWING IS A CONTROLLED DOCUMENT.		DWN	L. MAYER	3-15-85	TE TE Connectivity																		
DIMENSIONS: INCHES		CHK	T. ZOLA	5-21-85																			
TOLERANCES UNLESS OTHERWISE SPECIFIED:		APVD	R. FLICKER	5-21-85																			
<table border="1"> <tr><td>0 PLC</td><td>±</td><td>-</td></tr> <tr><td>1 PLC</td><td>±</td><td>-</td></tr> <tr><td>2 PLC</td><td>±</td><td>-</td></tr> <tr><td>3 PLC</td><td>±</td><td>.005</td></tr> <tr><td>4 PLC</td><td>±</td><td>-</td></tr> <tr><td>ANGLES</td><td>±</td><td>-</td></tr> </table>		0 PLC	±	-		1 PLC	±	-	2 PLC	±	-	3 PLC	±	.005	4 PLC	±	-	ANGLES	±	-	PRODUCT SPEC	NAME	
0 PLC	±	-																					
1 PLC	±	-																					
2 PLC	±	-																					
3 PLC	±	.005																					
4 PLC	±	-																					
ANGLES	±	-																					
MATERIAL: HOUSING-FLAME RETARDENT THERMOPLASTIC. COLOR-BLACK. POSTS-PHOS BRONZE.		FINISH: POSTS-.00030 GOLD ON THE CONTACT AREA. GOLD FLASH ON SOLDER AREA. ALL OVER .00050 NICKEL.		WEIGHT	-	SIZE	A2	CAGE CODE	00779	DRAWING NO	C=87215	RESTRICTED TO	-										
CUSTOMER DRAWING										SCALE	-	SHEET	1 of 1	REV	K								

单击下面可查看定价，库存，交付和生命周期等信息

[>>TE Connectivity\(泰科\)](#)