

4

3

2

1

THIS DRAWING IS UNPUBLISHED. RELEASED FOR PUBLICATION  
 © COPYRIGHT 2011 BY TYCO ELECTRONICS CORPORATION. ALL RIGHTS RESERVED.

LOC		DIST		REVISIONS					
DW		-		P	LTR	DESCRIPTION	DATE	DWN	APVD
				A		FIRST RELEASED	12JAN11	AW	WK

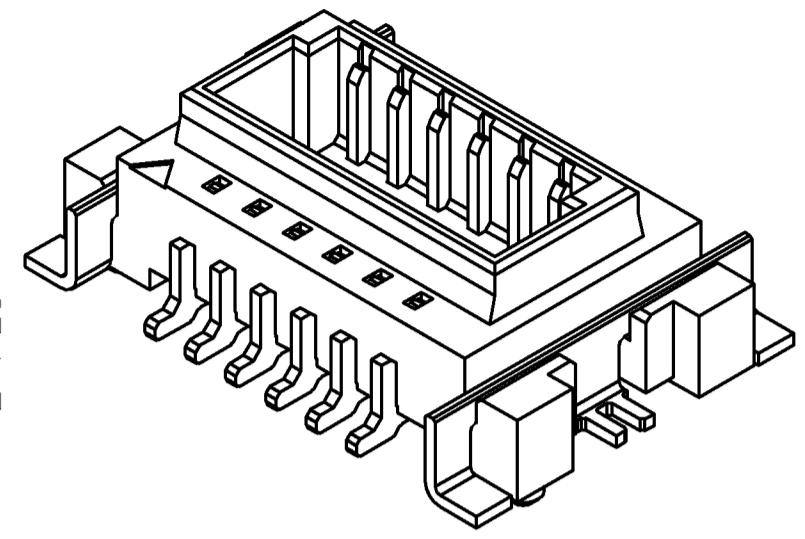
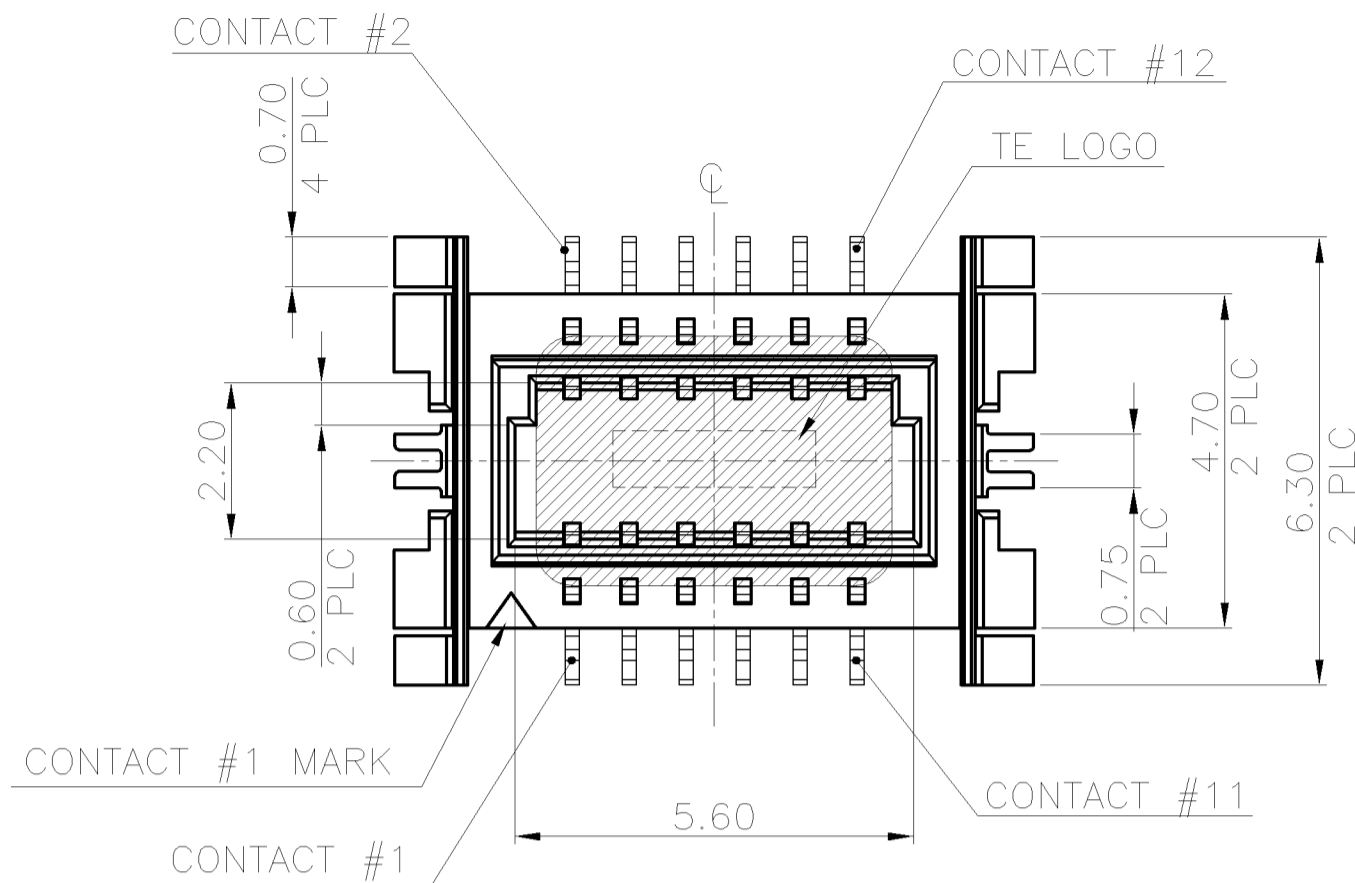

- NOTES:
- MATERIAL:  
 HOUSING: PA6T WITH 30% GF, UL94 V-0, NATURAL COLOR.  
 CONTACTS: PHOSPHOR BRONZE.  
 PEGS: BRASS.  
 MYLAR: POLYSTYRENES, ORANGE COLOR.
  - FINISH:  
 CONTACTS: GOLD FLASH OVER 1.27μm [50μ"] MIN. NICKEL ON ENTIRE CONTACT.  
 PEGS: 3.05μm [120μ"] MIN. MATTE-TIN OVER 1.27μm [50μ"] MIN. NICKEL.
  - REFLOW SOLDER CAPABLE TO 260°C PER TEC-109-201, CONDITION B.
  - SUBSTANCE RESTRICTIONS FOR LOW HALOGEN (BY WEIGHT):  
 BROMINE (Br) ≤ 900 PPM (0.09%)  
 CHLORINE (Cl) ≤ 900 PPM (0.09%)  
 TOTAL CONCENTRATION OF CHLORINE (Cl) + BROMINE (Br) ≤ 1500 PPM (0.15%)

△ MATING RECEPTACLE PART NUMBER: 1775013-1.

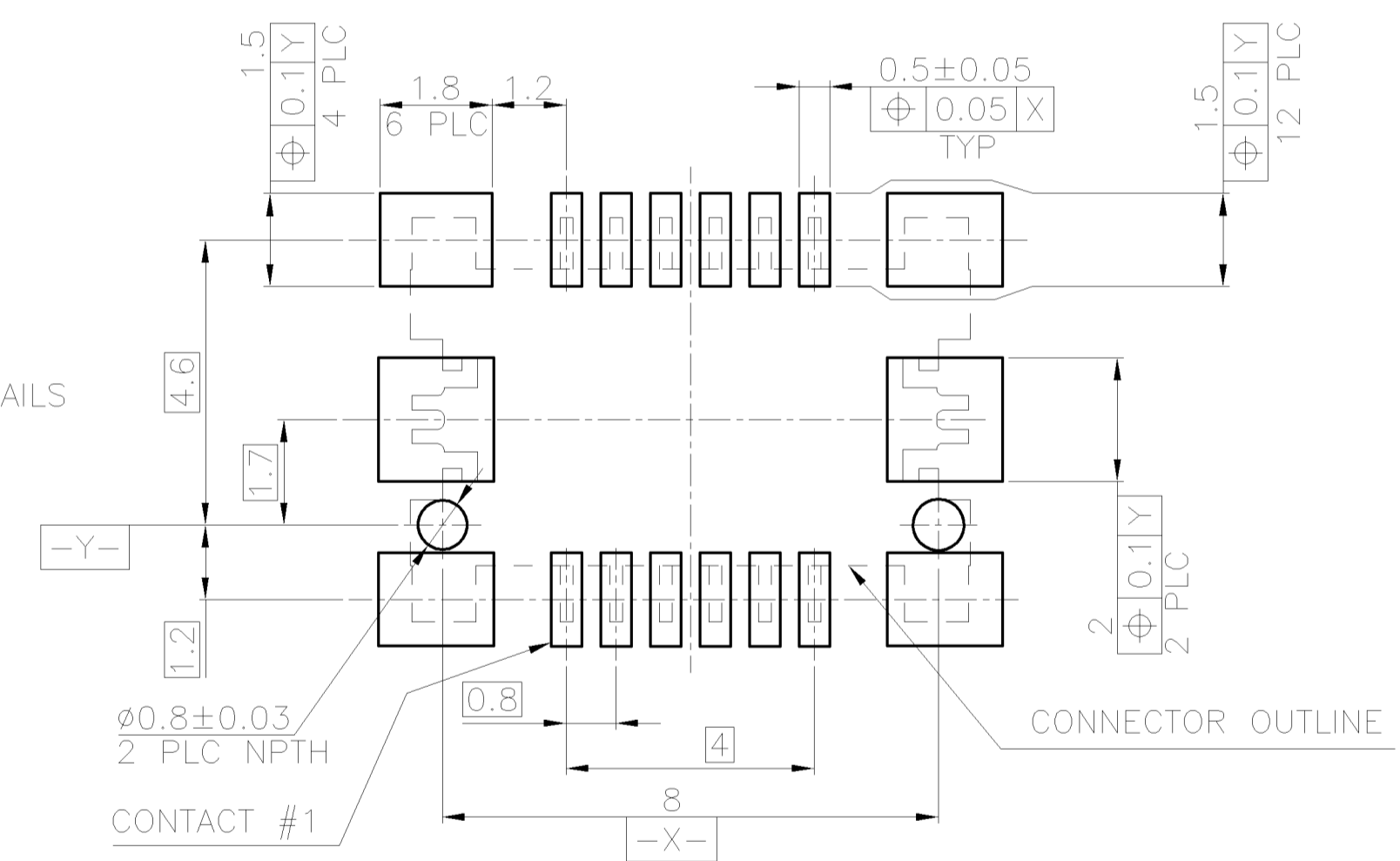
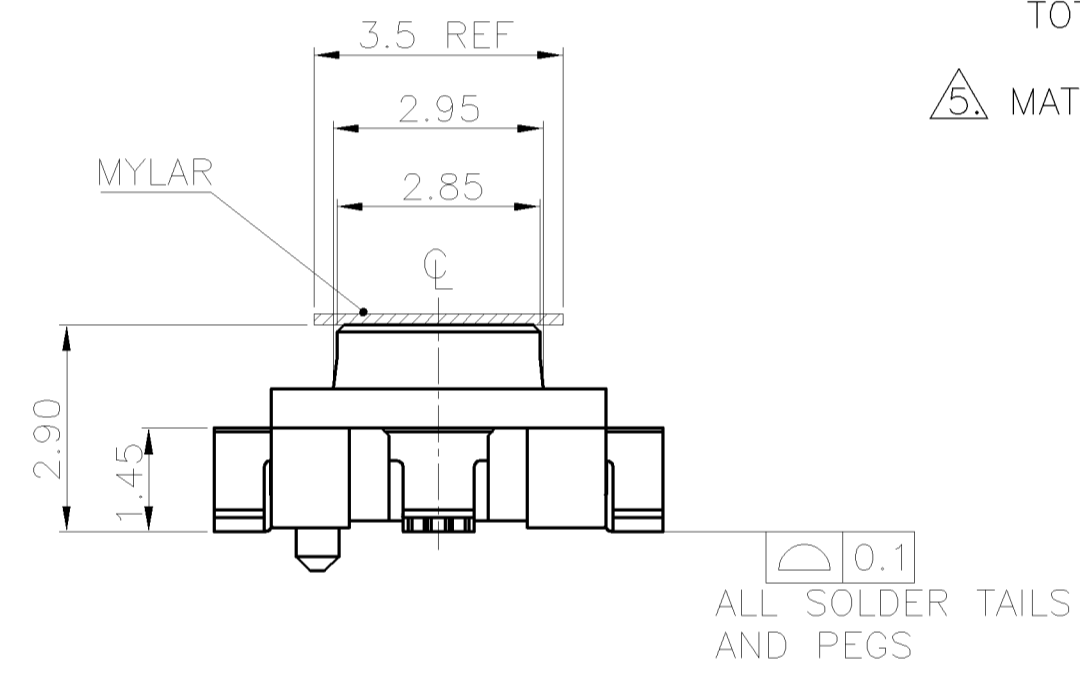
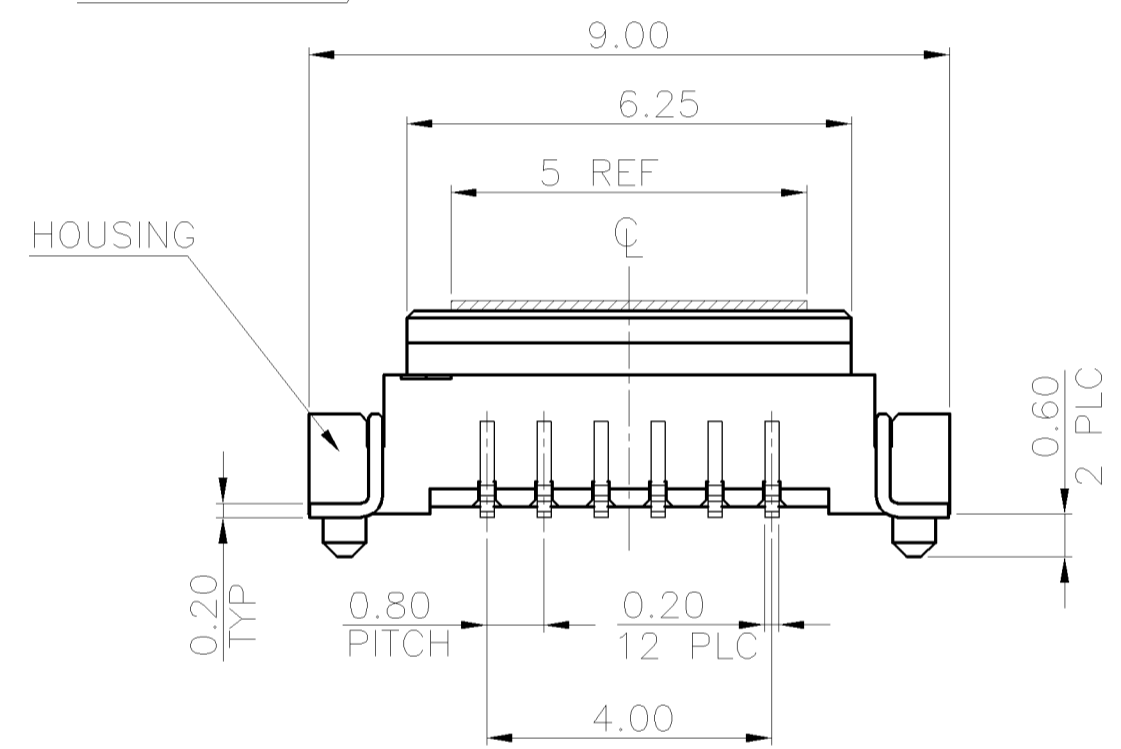

TOLERANCE: ±0.05  
 RECOMMENDED PCB LAYOUT  
 (TOP VIEW)

1-2041342-2  
 PART NUMBER

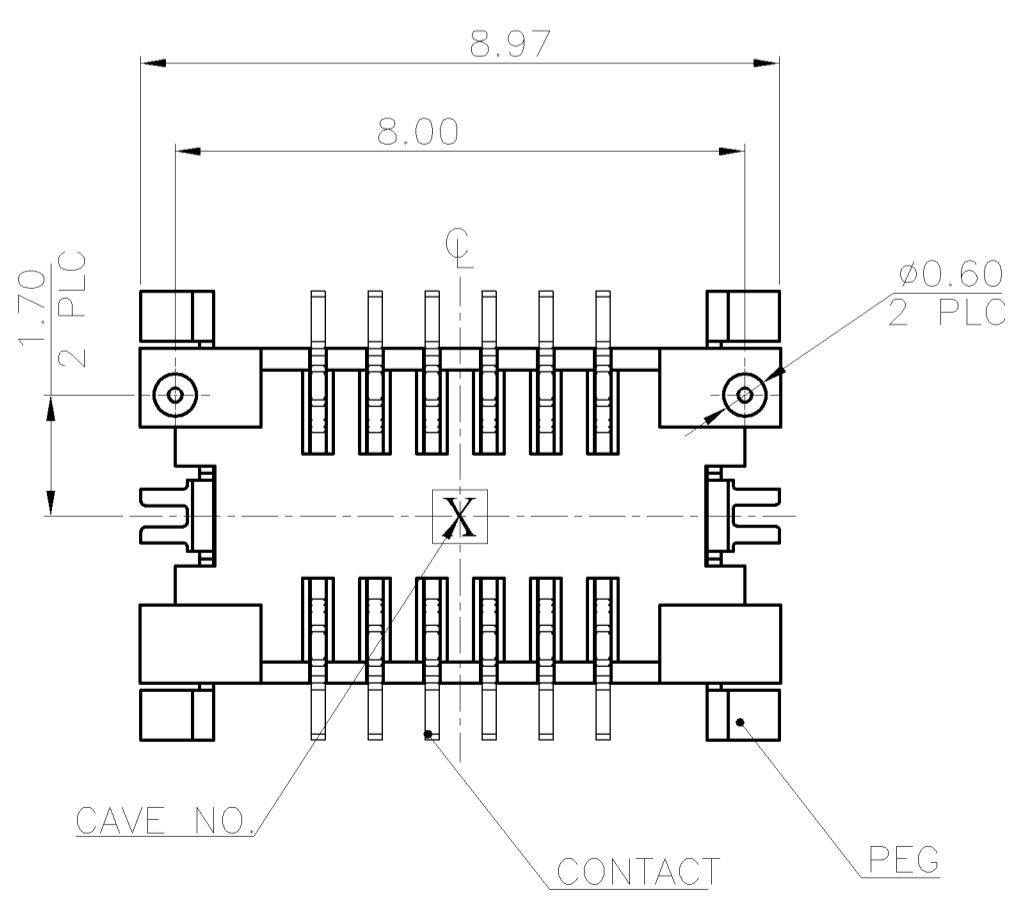
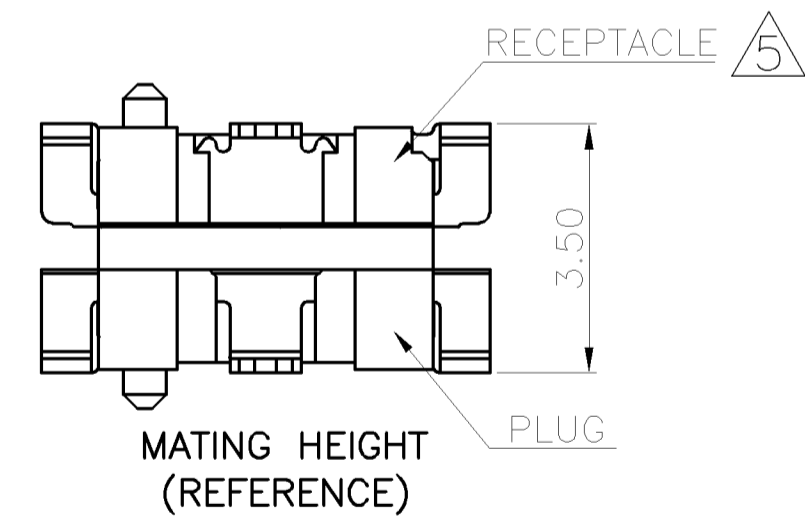

THIS DRAWING IS A CONTROLLED DOCUMENT.		DWN A. WU 12JAN2011	Tyco Electronics Corporation Taipei, Taiwan		
DIMENSIONS: MM		CHK S. CHIEN 12JAN2011	NAME		
TOLERANCES UNLESS OTHERWISE SPECIFIED:		APVD W. KODAMA 12JAN2011	0.8 PITCH BOARD-TO-BOARD CONNECTOR, SMT, 12 POSITION, PLUG		
0 PLC ± 0.5		PRODUCT SPEC 108-57849	SIZE	CAGE CODE	DRAWING NO
1 PLC ± 0.3		APPLICATION SPEC	A3	00779	C=2041342
2 PLC ± 0.2		WEIGHT 0.16 GRAMS	RESTRICTED TO		
3 PLC ± 0.15		CUSTOMER DRAWING	SCALE	SHEET	REV
4 PLC ± -			-	1 OF 2	A
ANGLES ± 3°					
FINISH SEE NOTE					

THIS DRAWING IS UNPUBLISHED. RELEASED FOR PUBLICATION  
 © COPYRIGHT 2011 BY TYCO ELECTRONICS CORPORATION. ALL RIGHTS RESERVED.

LOC	DIST	REVISIONS					
DW	—	P	LTR	DESCRIPTION	DATE	DWN	APVD
				SEE SHEET 1.			

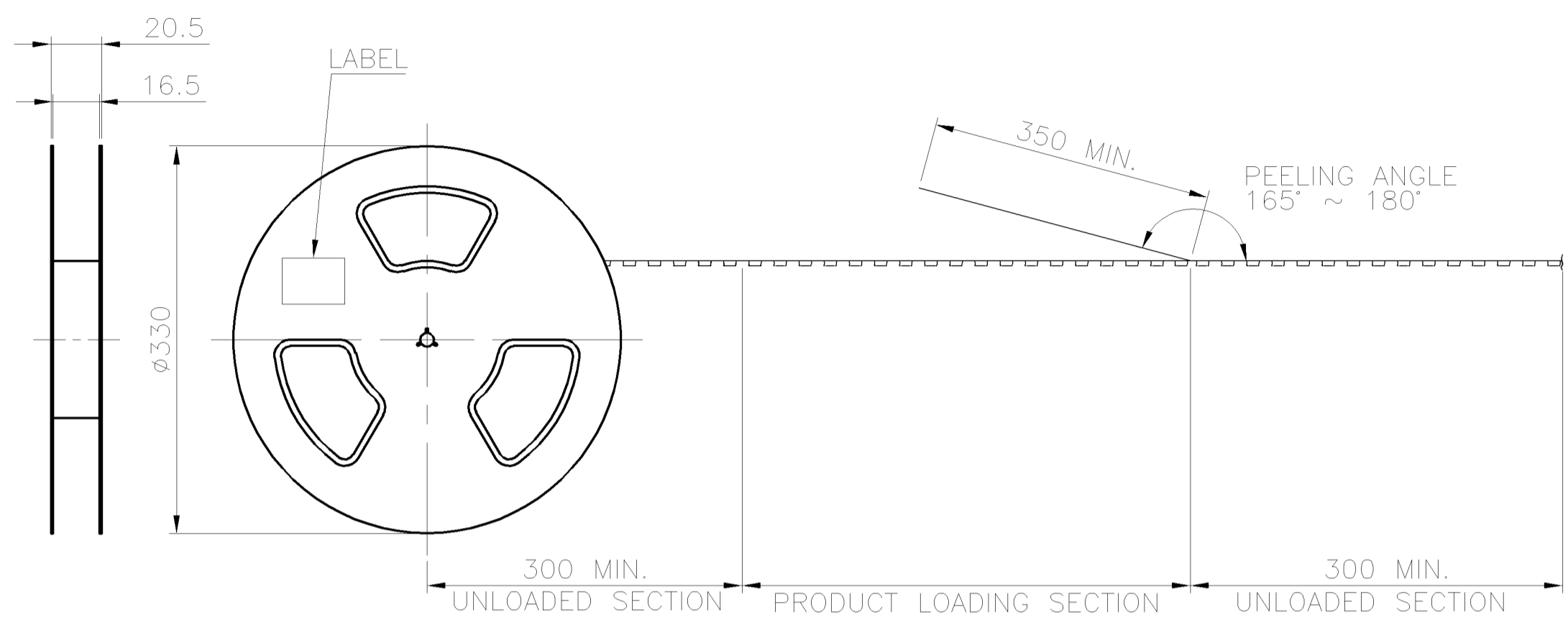

NOTES:

- MATERIAL:  
 BOX: FIBREBOARD, CORRUGATED, DOUBLE WALL.  
 COVER TAPE: PET, TRANSPARENT COLOR.  
 CARRIER TAPE: POLYSTYRENES, TRANSPARENT COLOR.  
 REEL: HIPS, BLUE COLOR.  
 BAG: POLYETHYLENES, TRANSPARENT COLOR.
- EACH BAG SHALL BE INCLUDED DESICCANT.
- PEELING STRENGTH: 0.1 ~ 1.3 N (10 ~ 130 GRAMS).
- PEELING SPEED: 300 mm/min.

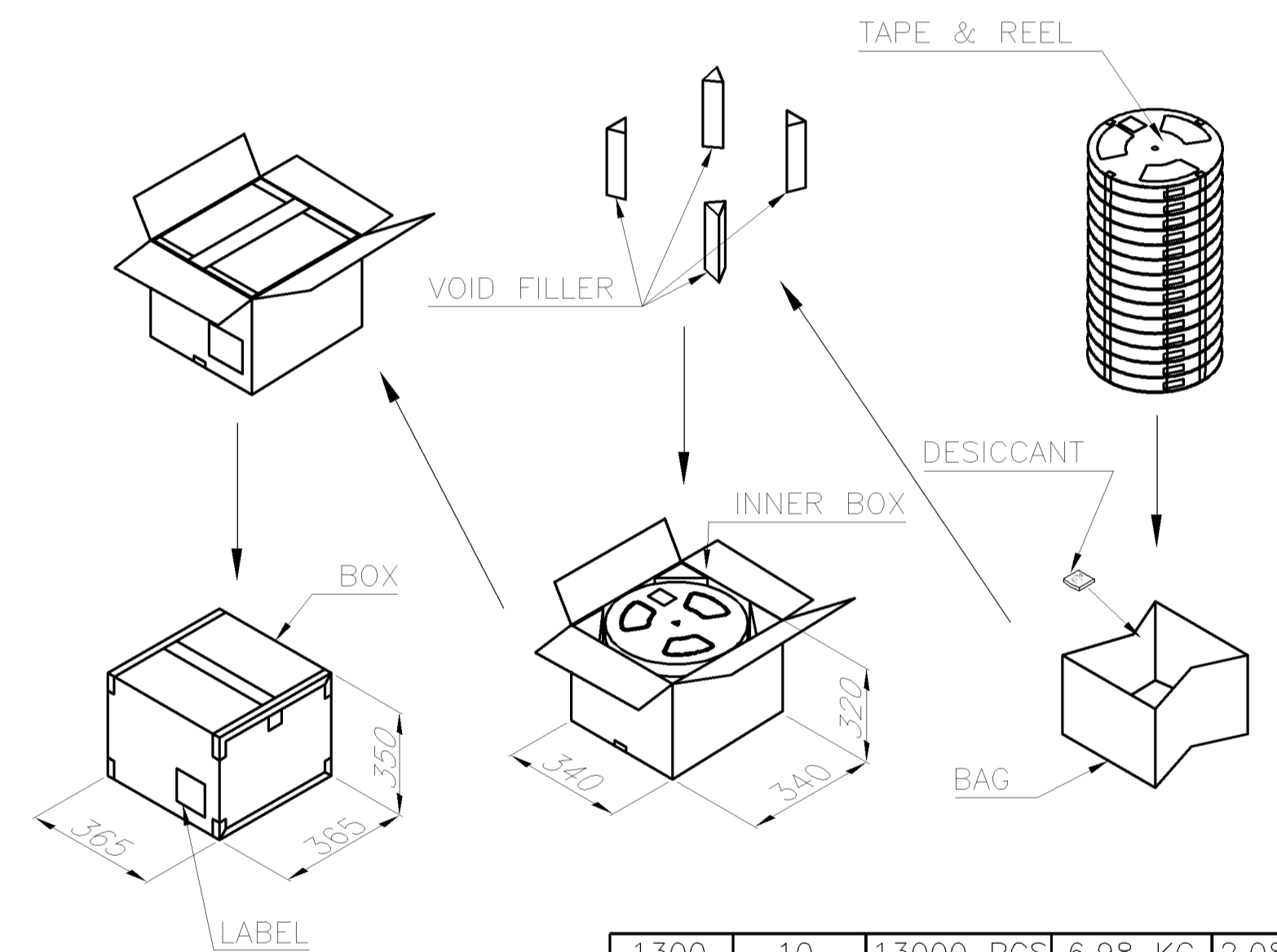
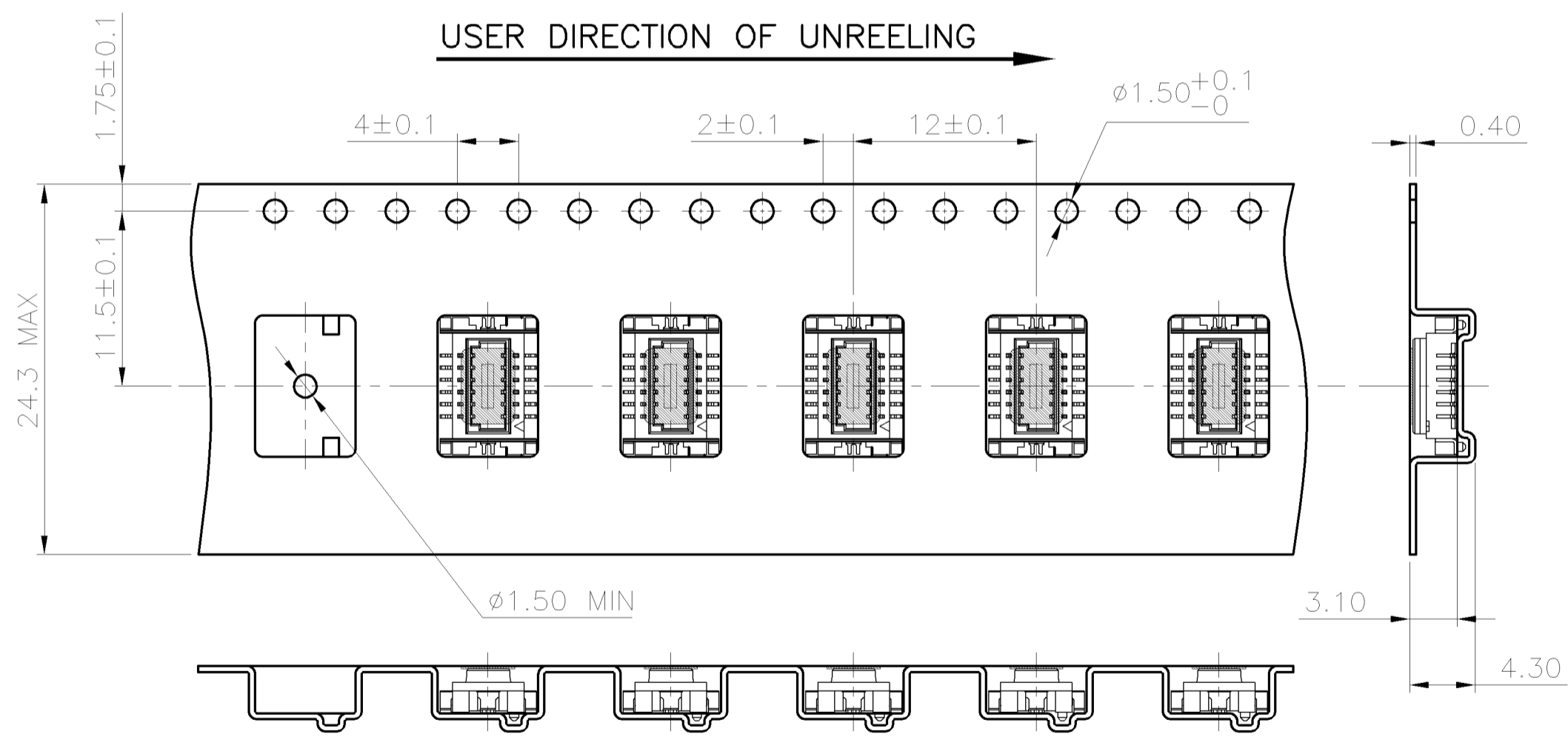

1300	10	13000 PCS	6.98 KG	2.08 KG
PCS/TAPE	REELS/BOX	QUANTITY	GROSS WEIGHT	NET WEIGHT

THIS DRAWING IS A CONTROLLED DOCUMENT.		DWN A. WU 12JAN2011	Tyco Electronics Corporation Taipei, Taiwan	
DIMENSIONS: MM		CHK S. CHIEN 12JAN2011		
TOLERANCES UNLESS OTHERWISE SPECIFIED:		APVD W. KODAMA 12JAN2011	NAME	
0 PLC ± - 1 PLC ± - 2 PLC ± - 3 PLC ± - 4 PLC ± - ANGLES ± -		PRODUCT SPEC	0.8 PITCH BOARD-TO-BOARD CONNECTOR, SMT, 12 POSITION, PLUG	
MATERIAL		FINISH	SIZE	RESTRICTED TO
			A3	
			CAGE CODE	
			00779	
			DRAWING NO	
			C=2041342	
			WEIGHT	
			—	
			CUSTOMER DRAWING	
			SCALE	
			—	
			SHEET	
			2 OF 2	
			REV	
			A	

单击下面可查看定价，库存，交付和生命周期等信息

[>>TE Connectivity\(泰科\)](#)